

Installation and Operation Manual

Navien Air Conditioner NAA Series (24K/36K/48K/60K, R454B)

Model | NAA17V36-24K/36K
NAA17V60-48K/60K



ALWAYS read and follow this manual completely before using the air conditioner. This manual should remain with the unit for future reference.

WARNING

FIRE OR EXPLOSION HAZARD

Improper installation, operation, or service can damage the air conditioner, your home, and other property and can create hazards such as fire, burns, electric shock, and explosion, which can result in serious injury or death.

For use with R-454B indoor units only. The manufacturer recommends installing only indoor and outdoor systems that are approved and compatible. Read the entire user guide before starting installation.

This appliance must be installed and serviced by a technician qualified under all local and national building codes.

Follow all safety codes. Wear safety glasses, protective clothing and work gloves. Use a quenching cloth for brazing operations. Have a dry powder or carbon dioxide fire extinguisher available during installation. Read this manual thoroughly and follow all warnings or cautions contained in the literature and attached to the appliance. Refer to the latest version of your local building code and the National Electrical Code (NEC) NFPA 70. In Canada, refer to the latest version of the Canadian Electrical Code CSA 22.1.

Contents

Important Safety Information 3

GENERAL 10

1. About the Air Conditioner 11

- 1.1 Included Items 11
- 1.2 Dimensions 11
- 1.3 Specifications 12
- 1.4 Components 13

2. Installing the Air Conditioner 14

- 2.1 Choosing an Installation Location 14
- 2.2 Installing on a Mounting Pad 15
- 2.3 Connecting the Refrigerant Line 16
- 2.4 Installing a Buried Line 17
- 2.5 Installing a Vertical-Lineset 17
- 2.6 Brazing the Refrigerant Line 19
- 2.7 Connecting the Line Voltage 23
- 2.8 Unit Configuration 24
- 2.9 Refrigerant Charging 25
- 2.10 System Startup 26

3. Installation Checklist 30

4. Operating the System and Setting the DIP Switches 31

- 4.1 Control Logic Description 31
- 4.2 SW1 DIP SWITCH Description 31
- 4.3 Compressor Crankcase Heater Control Function 32
- 4.4 Sensors and Valves 32
- 4.5 System Protection 35
- 4.6 Care and Maintenance 37

5. Appendixes 38

- 5.1 Thermostat Wiring Diagram 38
- 5.2 Overview of Main Control Board 42
- 5.3 Wiring Diagram 44

6. LIMITED WARRANTY NAVIEN, INC. 46

Product Installation Information	
Model	
Date Purchased	
Serial Number	

Important Safety Information



The following Safety Alert Symbols are used in this manual. They are used to alert you to potential personal injury hazards. Obey all safety messages that follow this symbol to avoid possible serious injury or death. This Safety Alert Symbol precedes any safety message about risk of personal injury. It may also be accompanied by one of the following signal words.

If the information in these instructions is not followed exactly, a fire or explosion may result, causing property damage, personal injury or death.

DANGER

Indicates a hazardous situation that if not avoided will result in death or serious injury.

WARNING

Indicates a hazardous situation that if not avoided could result in death or serious injury.

CAUTION

Indicates a potentially hazardous situation that if not avoided could result in minor or moderate injury.

NOTICE

Indicates information considered important but not hazard-related (such as property damage).

DANGER

Electrical Shock Hazards



- Disconnect all remote electric power supplies before servicing. Follow proper locking/tagging procedures to ensure that the power supply will not be energized accidentally.
- After power is disconnected, always wait a minimum of five minutes before working on anything electrical. This allows the voltage to dissipate from the inverter. Failure to do so may result in injury or death.

WARNING

This product may expose you to chemicals including lead and lead components, which are known to the State of California to cause cancer and birth defects or other reproductive harm. For more information, visit www.P65Warnings.ca.gov.

WARNING

- Installation and servicing of air conditioning equipment can be hazardous due to internal refrigerant pressure and live electrical components. Only trained and qualified service personnel should install, service, or provide maintenance on this equipment. Installation and service performed by unqualified persons can result in property damage, personal injury, or death.
- Product removal and recycling must be performed by a certified technician.
- The equipment is designed to be operated in an outdoor area.
- Installation must comply with all provincial, state, and local codes as well as the National Electrical Code (U.S.) or Canadian Electrical Code (Canada).
- Before accessing the electrical terminals, all power circuits must be disconnected.

WARNING

The instructions shall state the substance of the following:

This appliance is not intended for use by persons (including children) with reduced physical, sensory or mental capabilities, or lack of experience and knowledge, unless they have been given supervision or instruction concerning use of the appliance by a person responsible for their safety.

Children should be supervised to ensure that they do not play with the appliance.

WARNING

Refrigerant Oil

USE ONLY R-454B REFRIGERANT AND APPROVED COMPRESSOR OIL

- Attempting to repair central air-conditioning products may result in property damage, serious personal injury or death. Use only service equipment approved for use with R-454B.
- This system uses POE oil (VG74, VG75, or an equivalent system), which can easily absorb moisture from the atmosphere. If the system is exposed to the atmosphere for more than 4 hours, the compressor oil must be changed.
- The filter drier must be replaced when the refrigerant system is opened.

WARNING

Brazing Required

- Brazing should only be done on refrigerant tubes that are open to the atmosphere or are properly exhausted.
- If using existing refrigerant lines, make sure that all joints are brazed, not soldered.

WARNING

- Do not use any means to accelerate the defrosting process or to clean, other than those recommended by the manufacturer.
- The appliance shall be stored in a room without continuously operating ignition sources (for example: open flames, an operating gas appliance or an operating electric heater.)
- Do not pierce or burn.
- Be aware that refrigerants may not contain an outdoor unit.

WARNING

Qualification of workers

Every working procedure like maintenance, service and repair operations that affects safety means shall only be carried out by competent persons.

Examples for such working procedures are:

- Breaking into the refrigerating circuit;
- Opening of sealed components;
- Opening of ventilated enclosures.

WARNING

Checks to the area

Prior to beginning work on systems containing FLAMMABLE REFRIGERANTS, safety checks are necessary to ensure that the risk of ignition is minimized.

Work procedure

Work shall be undertaken under a controlled procedure so as to minimize the risk of a flammable gas or vapour being present while the work is being performed.

WARNING

When installing and repairing the system, comply with the following precautions prior to conducting work:

- Contact a qualified installer, service provider, or distributor for information or assistance. Qualified installers or agencies must use factory-approved kits or accessories when modifying this product.
- Refer to the individual instructions packaged with the kits or accessories.
- Have a dry powder or CO2 fire extinguisher available.
- Work must be executed using a controlled procedure so as to minimize the risk of flammable gases or vapors while working.
- All maintenance staff and others working in the local area must be instructed about the nature of the work being carried out. Work must not be done in confined spaces.
- The area must be checked with an appropriate refrigerant detector prior to and during work, to ensure the technician is aware of potentially toxic or flammable substances. Ensure that the leak detection equipment being used is suitable for use with R454B refrigerant, being non-sparking, adequately sealed or intrinsically safe.
- Any person carrying out work in relation to a refrigerant system which involves opening the sealed refrigerant system must use any sources of ignition in such a manner to eliminate any risk of fire or explosion. All possible ignition sources, including lit cigarettes, must be kept sufficiently far away from the places of installation, repair, removal and disposal, as refrigerant can possibly be released in the surrounding space. Prior to work taking place, the area around the equipment must be surveyed to make sure that there are no flammable hazards or ignition risks. "No Smoking" signs must be displayed.

WARNING

Ventilated Area

Ensure that the area is in the open or that it is adequately ventilated before opening the system or conducting any brazing work. There must be ventilation when working. Ventilation must be adequate for safely dispersing any refrigerant accidentally released and expelling it from the workspace.

WARNING

Checking Refrigerating Equipment

- When electrical components are changed, they must be fit for the purpose and meet the correct specifications. At all times the manufacturer's maintenance and service guidelines must be followed. If in doubt, consult the manufacturer's technical department for assistance.
- Only appropriate tools designed for R454B A2L refrigerant should be used. For A2L refrigerants, non-sparking tools are required.
- The following checks must be applied to installations using flammable refrigerant.
 - The actual refrigerant charge is in accordance with the size of the room that the refrigerant containing components are installed in.
 - The ventilation machinery and outlets are operating adequately and are not obstructed.
 - The secondary circuit must be checked for the presence of refrigerant if a secondary refrigerating circuit is being used.
 - The markings on the equipment continue to be visible and legible. Markings and signs that are illegible must be corrected.
 - The refrigerating pipe or components are installed in a position where they are unlikely to be exposed to any substance that may corrode the refrigerant containing components, unless the components are constructed of materials that are inherently resistant to being corroded or are suitably protected against corrosion.

WARNING

Checking to Electrical Devices

- Repair and maintenance of electrical components must include initial safety checks and component inspection procedures. If a fault exists that could compromise safety, do not connect the electrical supply to the unit until it is satisfactorily dealt with. If the fault cannot be corrected immediately but it is necessary to continue operation, an adequate temporary solution should be used. This must be reported to the owner of the equipment so all parties are advised.
- Initial safety checks must include the following:
 - Discharging of capacitors: must be done in a safe manner to avoid the possibility of sparking.
 - Ensuring no live electrical components or wiring is exposed while charging, recovering or purging the system.
 - There is continuity of earth grounding.
 - Before servicing any electrical components involving the compressor or inverter, disconnect the power and allow the system to sit for a minimum of 5 minutes to give time for all electrical capacitors to discharge.

WARNING

Sealed electrical components must be replaced.

- During repairs to sealed components, all electrical supplies must be disconnected from the equipment being worked upon prior to any removal of sealed covers, etc. If it is absolutely necessary to have electricity supplied to the equipment during servicing, then a permanently operating form of leak detection must be located at the most critical point to warn of a potentially hazardous situation.
- Particular attention must be paid to the following to ensure that the casing is not altered in such a way that the level of protection is affected during work. Attention should be paid to not damaging cables, not creating excessive connections, avoiding the creation of terminals not made to the original specification, damaging seals, incorrect fitting of glands, etc.
- Ensure that the apparatus is mounted securely.
- Ensure that seals or sealing materials have not degraded to the point that they no longer prevent the ingress of flammable gases. Replacement parts must be in accordance with the manufacturer's specifications.

WARNING

Components must be intrinsically safe.

- Do not apply any permanent inductive or capacitance loads to the circuit without ensuring that this will not exceed the permissible voltage and current permitted for the equipment in use.
- Intrinsically safe components are the only types that can be worked on while live in the presence of a flammable atmosphere. The test apparatus must be at the correct rating.
- Replace components only with parts specified by the manufacturer. The use of unapproved parts may result in the ignition of refrigerant in the atmosphere from a leak.

WARNING

Cabling

All cables and wiring should be installed such that it is not subject to unnecessary wear, corrosion, excessive pressure, vibration, contact with sharp edges, or any other adverse environmental effects.

WARNING

Detection of Flammable Refrigerants

- Under no circumstances should sources of ignition be used to search for or detect refrigerant leaks. Halide torches or any other detectors that use a naked flame must not be used.
- The following leak detection methods are deemed acceptable for all refrigerant systems:
 - Electronic leak detectors specifically designed to detect A2L refrigerants must be used to detect refrigerant leaks. (Detection equipment must be calibrated in a refrigerant-free area.) Ensure that the detector is not a potential source of ignition and is suitable for the refrigerant used. Leak detection equipment must be set to the LFL percentage of the refrigerant and must be calibrated to the refrigerant employed, and the appropriate percentage of gas (25 % maximum) is confirmed.
 - Leak detection fluids are also suitable for use with most refrigerants but the use of detergents containing chlorine must be avoided as the chlorine may react with the refrigerant and corrode the copper pipe-work.
 - When using a fluid, use either the bubble method or the fluorescent agent method for leak detection.
- If it is suspected that there is a leak, all flames must be removed/extinguished.
- If a refrigerant leak is found which requires brazing, all of the refrigerant must be recovered from the system, or isolated (by means of shut off valves) in a part of the system that is far from the leak. Removal of refrigerant must be performed according to specifications in the Removal and Evacuation section of this manual.

WARNING

Removal and Evacuation

- When opening the refrigerant system to make repairs or for any other purpose, the conventional procedures should be used. However, for flammable refrigerants it is important that the best practices be followed. The following procedure must be adhered to:
 1. Safely remove refrigerant following local and national regulations.
 2. Evacuate.
 3. Purge any tubing or braze joint with an inert gas while brazing.
 4. Continuously purge with inert gas when using a flame to open the reclaimed and evacuated refrigerant system.
- The refrigerant charge must be recovered in appropriate recovery cylinders. The system must be purged with oxygen-free nitrogen to render the appliance safe for flammable refrigerants. This process might need to be repeated several times. Compressed air or oxygen must not be used for purging refrigerant systems.
- For appliances containing flammable refrigerants, refrigerant purging must be achieved by breaking the vacuum in the system with oxygen-free nitrogen and continuing to fill it until the working pressure is achieved, then venting into the atmosphere, and finally pulling down to a vacuum. This process must be repeated until no refrigerant remains in the system. When the final oxygen-free nitrogen charge is used, the system must be vented down to atmospheric pressure to enable work to take place.
- The outlet for the vacuum pump must not be close to any potential ignition sources, and the area must be well ventilated.

WARNING

Decommissioning

Before carrying out this procedure, it is essential that the technician is completely familiar with the equipment. It is recommended that all refrigerants have been safely removed. Prior to recovery, an oil and refrigerant sample should be taken for analysis if the recovered refrigerant is to be re-used. It is essential that electrical power is available before the task is commenced.

- Become familiar with the equipment and its operation.
- Isolate system electrically.
- Before attempting the procedure, ensure that:
 - Mechanical handling equipment is available, if required, for handling refrigerant cylinders.
 - All necessary personal protective equipment is available and being used correctly.
 - The recovery process is supervised at all times by a competent person.
 - Recovery equipment and cylinders conform to the appropriate standards.
- Pump down the refrigerant system, if possible.
- If it is not possible to use a vacuum pump, make a manifold so that the refrigerant can be removed from the various parts of the system.
- Make sure that the cylinder is situated on the scales before recovery takes place.
- Start the recovery machine and operate it in accordance with the instructions.
- Do not overfill cylinders (no more than 80 % of cylinder capacity.).
- Do not exceed the maximum working pressure of the cylinder, even temporarily.
- When the cylinders have been filled correctly and the process has been completed, make sure that the cylinders and the equipment are removed from site promptly and all isolation valves on the equipment are closed.
- Recovered refrigerant must not be charged into another refrigerating system unless it has been cleaned and checked.

WARNING

Labeling

Equipment that has been de-commissioned and emptied of refrigerant must be labeled. The label must be dated and signed. Ensure that there are labels on the equipment stating the equipment contains flammable refrigerant.





WARNING

Recovery

- When removing refrigerant from a system, either for servicing or decommissioning, it is recommended that all refrigerant is safely reclaimed.
- When transferring refrigerant into cylinders, ensure that only appropriate refrigerant recovery cylinders are employed. Ensure that the correct number of cylinders for holding the whole system charge are available. All cylinders must be designated for the recovered refrigerant and labeled for that refrigerant. Cylinders must be complete with a pressure-relief valve and associated shut-off valves in good working order. Empty recovery cylinders must be flushed and, if possible, cooled before recovery occurs.
- The recovery equipment must be in good working order with a set of instructions concerning the equipment on hand, and the equipment must be suitable for the recovery of the flammable refrigerant. If in doubt, the manufacturer should be consulted. In addition, a set of calibrated weighing scales must be available and in good working order. Hoses must include leak-free couplings and be in good condition.
- The recovered refrigerant must be processed according to local regulations and be placed in the correct recovery cylinder, and the relevant waste transfer note attached. Do not mix refrigerants in recovery units and especially not in cylinders.
- If the compressors or compressor oils are to be removed, ensure that they have been flushed to an acceptable level to make certain that flammable refrigerant does not remain within the lubricant. The compressor body must not be heated by an open flame or other ignition sources to accelerate this process. When oil is drained from the system, it must be appropriately disposed of.

GENERAL

Marking and Instructions

 WARNING	This symbol denotes use of mildly flammable refrigerant.
 CAUTION	This symbol denotes that the operation manual should be read carefully.
 CAUTION	This symbol denotes that only service personnel should be handling the equipment in accordance with the installation manual.
 CAUTION	This symbol denotes that the information is available such as the operating manual or installation manual.

NOTICE

- Effective January 1, 2023, all split-system and packaged air conditioners must be installed pursuant to applicable the regional efficiency standards issued by the DOE.
- The indoor unit must be matched with the appropriate TXV as specified by the manufacturer.
- Units should only be installed with the approved indoor matches listed in the Air Conditioning and Refrigeration Institute (AHRI) Directory of Certified Products. Refer to <http://www.ahridirectory.org>.
- This document is the property of the customer and should be kept with the unit. When you are finished, store this manual near the indoor unit for future reference.

GENERAL

- The maximum allowed elevation is 10,000 feet (3000 meters) above sea level.
- Locate the unit away from windows, patios, decks, etc., where the sound of the unit running may disturb the customer.
- Ensure that the vapor and liquid tube diameters are appropriate for the unit's capacity.
- The maximum lineset length is 100 feet.
- The maximum vertical lift is 50 feet. See details on page 16 for trap requirements over 16 feet of vertical lift.

Move the equipment to its final location. Remove the carton, taking care not to damage the unit.

Inspecting the Equipment



File a claim with the shipping company prior to installation if anything is missing or if the equipment was damaged. Locate the unit rating plate that contains information needed to properly install the unit. Check the rating plate to be sure the unit matches the job specifications.

Checking the Visual Tubing

After setting the unit, check to be certain the factory tubing on the both indoor and outdoor unit has not shifted during shipment. Ensure the tubes are not rubbing against each other or any sheet metal. Pay close attention to TXV feeder tubes, making sure wire ties on the feeder tubes are secure and tight.

1. About the Air Conditioner

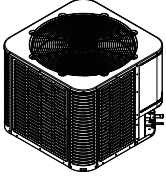
1.1 Included Items

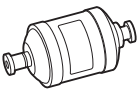
	
Air Conditioner	Installation and Operation Manual
	
Bi-Directional Filter Drier	

1.2 Dimensions

NAA17V36

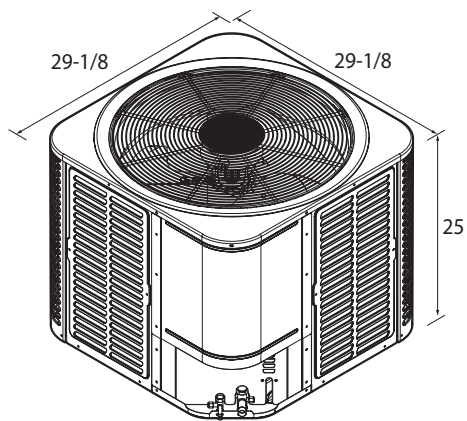

NAA17V60

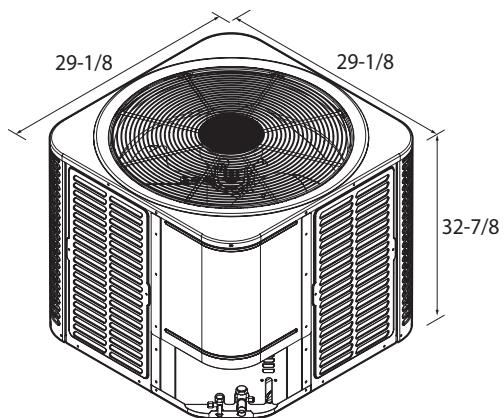

1.3 Specifications

The following table lists the specifications for the air conditioner.

Model Name		NAA17V36-24K/36K	NAA17V60-48K/60K
Electrical Data	Voltage (V) – Phase (Ph) – Hertz (Hz)	230 – 1 – 60	
	Minimum Circuit Ampacity (A)	20	30
	Max. Overcurrent Protection (A)	30	45
	Min / Max Volts (V)	187/253	
Compressor	Type	Rotary	
	Hz	18-78	
	Rated Current (RLA) (A)	12.8	20
	LRA	52	58.1
Fan Motor	Power Supply	DC	
	RLA (A)	1.8	1.8
	Maximum Speed (rpm)	1100	
	HP	1/4	
	FLA (A)	1.8	1.8
Coil	Number of Row	2	
	Tube Outside Diameter (inch)	9/32	
	Tube Pitch × Row Pitch (inch)	0.83 x 0.53	
	Net Face Area (sq. ft.)	13.75	18.35
Unit	Dimension (WxDxH) (inch)	29-1/8 x 29-1/8 x 25	29-1/8 x 29-1/8 x 32-7/8
	Packing (WxDxH) (inch)	29-7/8 x 29-7/8 x 29-3/8	29-7/8 x 29-7/8 x 37-1/4
	Net / Gross Weight (lbs)	137/166	185/214
	Sound Rating Level (dB(A))	78 at maximum capacity	
Refrigerant System	Refrigerant	R454B	
	Liquid Line (inch)	3/8	3/8
	Vapor Line (inch)	3/4	7/8
	Factory Charge (oz)	111.1	155.2
	Max. Line Length (ft)	100	
	Max. Vertical Lift (ft)	50	
Operating Temperature	Cooling Mode (°F (°C))	5~124(-15~51.2)	

1.4 Components

The following diagram shows the key components of the air conditioner.

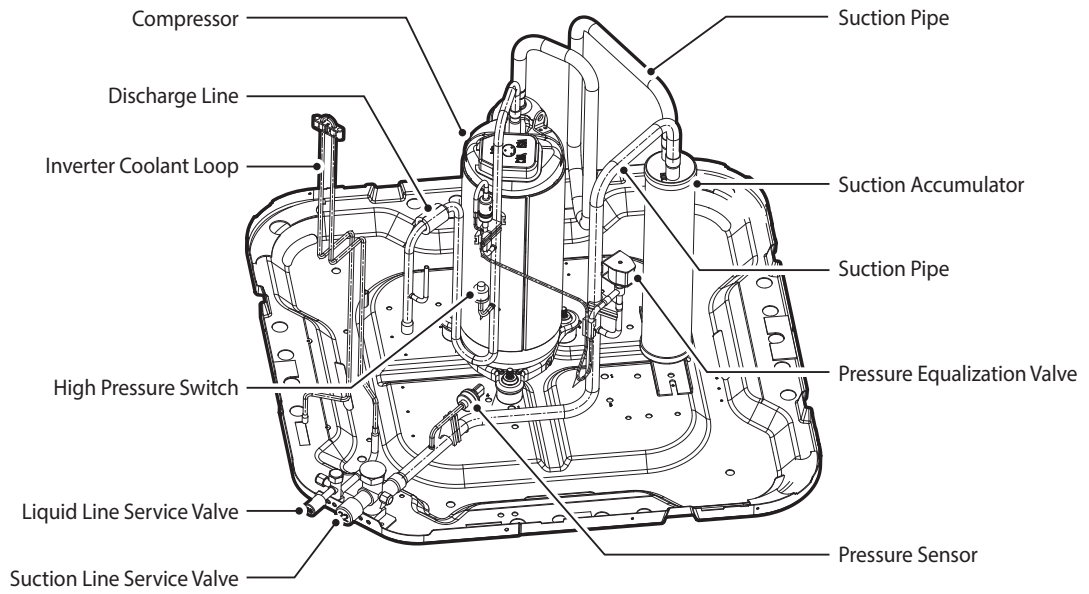

2. Installing the Air Conditioner

2.1 Choosing an Installation Location

Preparing the Unit for Installation

Check whether there is any damage and report any damage to the unit to the shipping company. Move the unit to its final location. Remove the carton, taking care not to damage the unit.

Ensuring Adequate Space (Clearances)

Ensure that the installation location provides adequate space (clearances) for airflow, wiring, the refrigerant lineset and maintenance.

- Allow 24" (610 mm) clearance for the service side of the unit.
- Allow 60" (1,524 mm) above the unit.
- Maintain a distance of 24" (610 mm) between units or 18" (457 mm) if there is no overhang within 12 ft. (4 m).
- Locate the outdoor unit away from the sleeping quarters to avoid any disruptive sound.

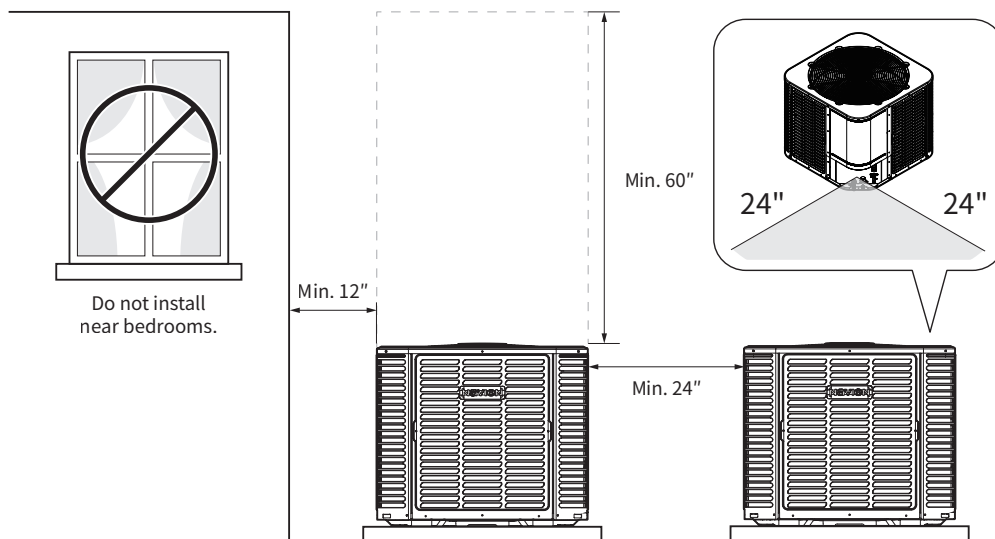

Location	Minimum Clearance Distance
Service Side	24" (610 mm)
Above Unit	60" (1,524 mm)
Between Units	24" (610 mm)
Against Wall	12" (305 mm)

- Position it so water, snow, or ice from the roof or eaves cannot fall directly on the unit.

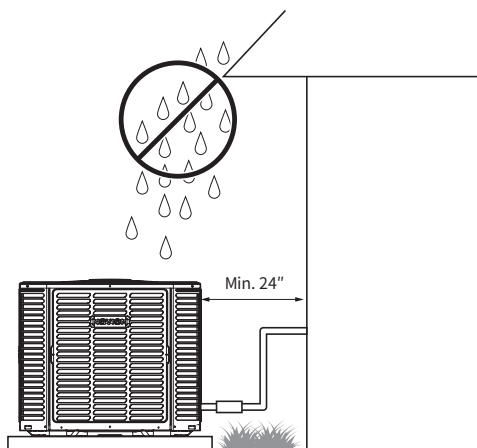

Corrosive Environments

Exposure to a corrosive environment will shorten the service life of the unit, corrode metal parts, and/or negatively affect the unit's performance. Corrosive elements include but are not limited to:

- Seawater: sodium chloride, sodium hydroxide, sodium sulfate, and other compounds.
- Industrial/manufacturing plants: sulfur, chlorine, fluorine, fertilizers and various chemical pollutants.

If it is installed in an area that may be exposed to a corrosive environment, special attention should be paid to the placement and maintenance of the unit.

- Lawn sprinklers/hoses/waste water should not be sprayed directly on the outer panel of the unit for prolonged periods.
- In coastal areas: install the unit on the side away from the waterfront.
- Fences or shrubs can provide some shielding protection for the unit, but the minimum device clearance must still be maintained.
- Clean the outdoor coil and any exposed external surfaces once every three months or as necessary, depending on the conditions of the installation using only tap water.

2.2 Installing on a Mounting Pad

When installing the unit on a support pad (such as a concrete slab), consider the following:

- All sides of the pad must be at least 1-2" larger than the unit.
- The pad must be separate from any structure.
- Slab should have a slope tolerance angled away from the building at 2° or 1/4" per foot.
- The pad must be high enough above the ground for drainage.
- The location of the pad must comply with national, state and local regulations.

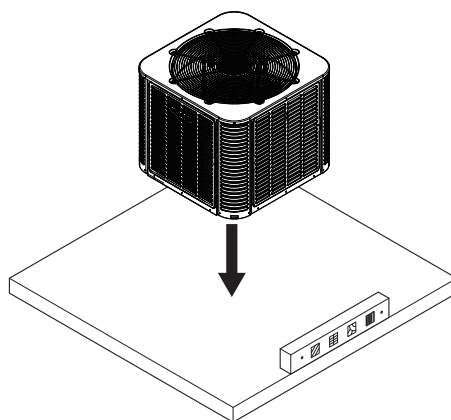

If conditions or local codes require the unit to be attached to a pad, tie down brackets should be used and fastened to the unit's base pan.

For hurricane tie downs, contact the distributor for details and a PE Certification (Professional Engineer), if required.

When installing on rooftops, mount on level platform or frame. Place the unit above a load-bearing wall and isolate the unit and tubing set from the structure. For units on rooftops, locate the unit at least 6 in. (152 mm) above the roof surface. Arrange supports to adequately support the unit and minimize the transmission of vibrations to the building. Consult local codes for rooftop installation.

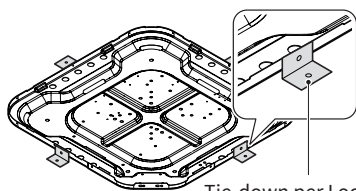

Tie-down per Local Code

2.3 Connecting the Refrigerant Line

The piping material, routing, and installation must include protection from physical damage during operation and service while in compliance with national and local codes and standards for the installation site.

Outdoor units must be connected to the indoor section using field-supplied refrigerant grade copper tubing of the correct size and condition. The vapor line (larger of the two) must be entirely insulated.

- Keep the lineset tubing from coming in direct contact with water pipes, ductwork, floor joists, wall studs, floors, or walls.
- Do not suspend refrigerant tubing from joists and studs with a rigid wire or strap which comes in direct contact with any tubing.
- When necessary, use hanger straps which are 1 in. (25 mm) wide and conform to the shape of the tubing insulation.
- Ensure that the tubing insulation is pliable and completely surrounds the vapor line.
- Do not allow the copper vapor and liquid line to come in direct contact with each other.
- Run the refrigerant lineset with as few bends as possible.

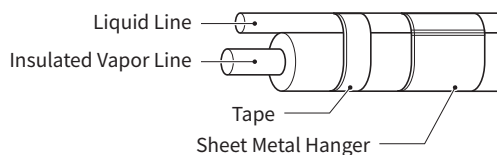
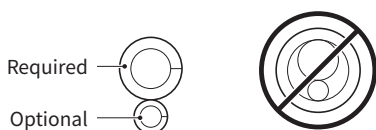

Model	Vapor Line	Liquid Line
NAA17V36	3/4"	3/8"
NAA17V60	7/8"	3/8"

Secure the refrigerant line from the joists using isolators every 8 ft. Secure the liquid line directly to the vapor line using tape or another appropriate method every 8 ft.

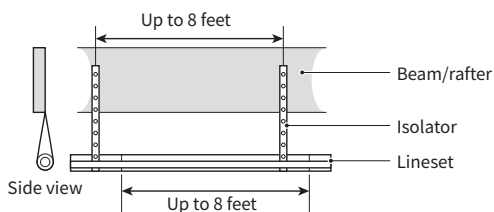

[Isolated from beam/rafter]

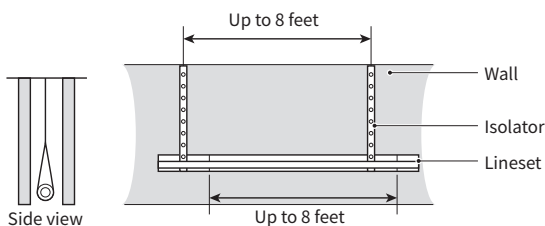

[Isolation on the wall]

2.4 Installing a Buried Line

Use a PVC chase sealed at both ends to prevent water from entering the chase.

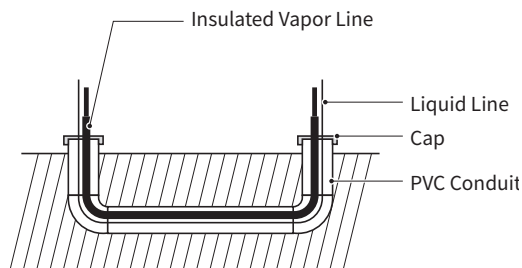

When passing refrigerant tubes through the wall, seal the opening with RTV or another pliable silicon-based caulk.

Provisions must be made for the expansion and contraction of long running pipes.

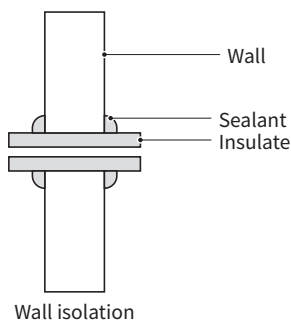

2.5 Installing a Vertical-Lineset

Note that the length of the connecting line from the outdoor unit to the indoor unit cannot exceed 100 feet. If all long lines are horizontal, no additional measurements are required.

The vertical height difference between the outdoor unit and the indoor unit cannot exceed 50 feet. If there is a vertical height difference in a long line, it needs to be installed according to the following requirements:

Vertical Height Difference (h, ft.)	Outdoor Unit lower than Indoor Unit	Outdoor Unit higher than Indoor Unit
$0 < h \leq 16.5$	A suction line trap is not required.	
$16.5 < h \leq 33$	Install one inverted trap near the indoor unit connection. The top of the trap loop must be higher than the top of the indoor coil.	Install one suction trap at approximately mid-height of the vertical rise.
$33 < h \leq 50$	Install two inverted traps: one near the indoor unit (top of loop higher than indoor coil) and one at approximately mid-height of the vertical rise.	Install two suction traps, evenly spaced along the vertical rise.

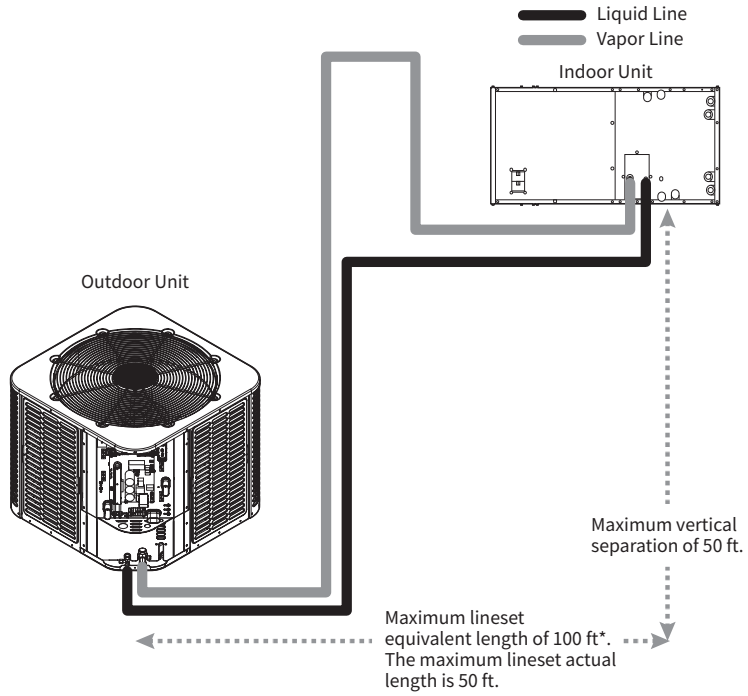

* Includes pressure losses of any elbow, bends, etc.

[Outdoor Unit lower than Indoor Unit]

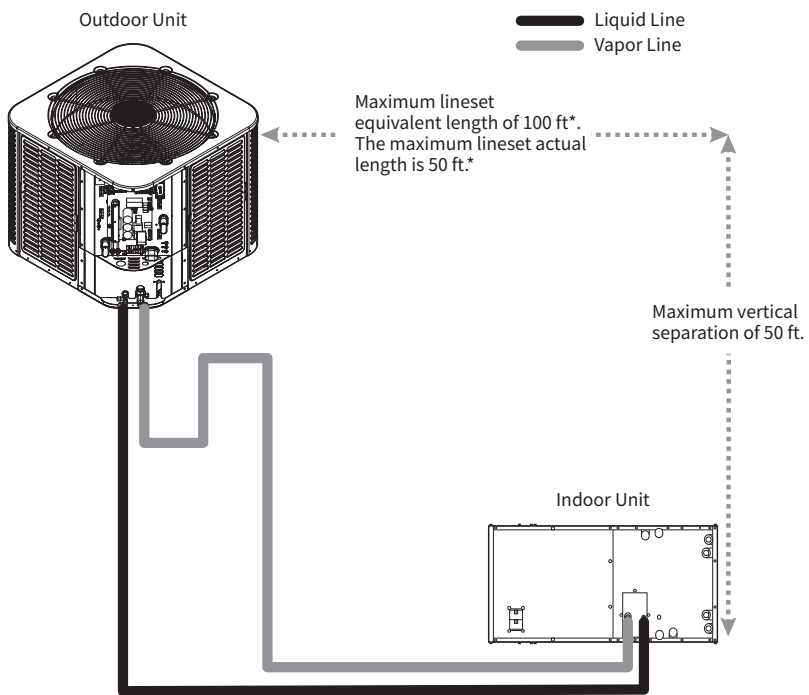

* Accounts for pressure losses of any elbow, bends, etc.

[Outdoor Unit higher than Indoor Unit]

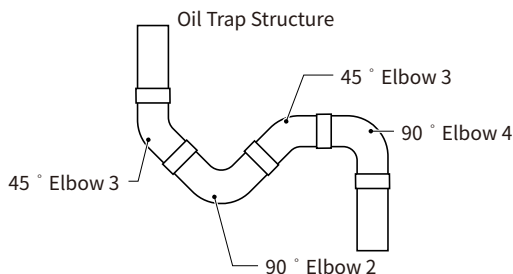

[Typical vertical suction trap configuration]

2.6 Brazing the Refrigerant Line

If the inside of the refrigerant tubes or the indoor coil are open to the atmosphere, they must be evacuated to 500 microns to eliminate contamination and moisture.

Refrigerant pipes should be installed at the minimum length that is possible and practical for the installation. Piping should be protected from physical damage during operation and maintenance and it must be in compliance with national and local codes such as ASRHAЕ 15, ASHRAЕ 15.2, the IAPMO Uniform Mechanical Code, the ICC International Mechanical Code, or CSA B52.

All field joints must be accessible for inspection prior to being covered or enclosed.

When installing the indoor and outdoor units at different elevations or levels, proper trappings must be used to prevent slugging or oil trapping, both of which could damage the system and shorten the service life of the equipment.

NOTICE

Service valves coming from the factory are supplied closed and capped. Outdoor units are shipped with a refrigerant charge sealed in the unit. Leave the service valves closed until all other refrigerant system work is complete or the charge will be lost. Leave the plugs in place until lineset tubing is ready to be inserted.

Reusing Existing Refrigerant Lines

The refrigerant lineset that the unit has been removed from must be properly flushed and kept clean and free of foreign substances. The following precautions should be taken for the retrofit application that will use the existing refrigerant lineset:

- Make sure the refrigerant line size is correct.
- Make sure the refrigerant line has been properly flushed and is free of leaks, acid, or oil.

If the existing lineset was used for any refrigerant other than what the unit is approved for, the appropriate recovery and flushing procedures must be performed. The refrigerant must be reclaimed in accordance with both national and local codes. Any existing filter drier must always be replaced with a new bi-directional filter drier.

Brazing Connections

Remove caps or plugs. Clean the lineset tube ends with an emery cloth or steel brush. Remove any grit or debris and prevent it from entering the tube or fitting being cleaned. Connect the vapor tube to the fitting on the outdoor unit vapor service valves. Connect the liquid tubing to the fitting on the liquid service valve. Use only refrigerant grade copper tubing.

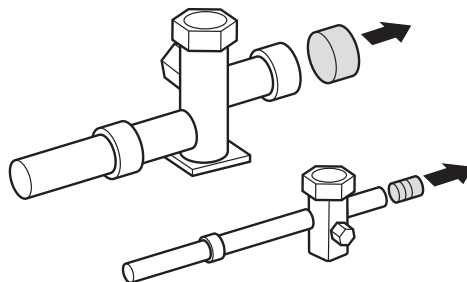

Purging Nitrogen

For the liquid and vapor service valves, be sure to remove the valve core from the Schrader port on the service valves BEFORE brazing. This helps prevent the damage to the valve seals and helps expedite processing. This is also where you will purge nitrogen through the lineset while brazing. Replace the valve cores when brazing is complete and the valves have completely cooled down.

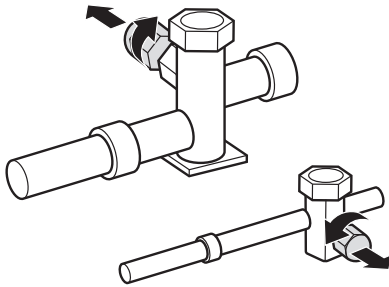

To prevent harmful oxidation from forming inside the tubing while brazing, let the regulated dry nitrogen flow (at 1 to 2 psig) through the refrigeration gauge set into the valve stem port connection on the liquid service valve and out of the vapor valve stem port on the manifold gauge set connections while brazing the lineset and filter drier.

Apply absorbing paste or a heat sink product between the service valve and the braze joint. Wrap the service valves with a heat sink material such as a wet cloth. After wrapping the service valves and outdoor ambient temperature sensor with a wet cloth, the lineset can be brazed to the service valve using either the silver bearing or non-silver bearing brazing material.

Braze joints using a sil-fos or phos-copper alloy and continue dry nitrogen purging during brazing.

NOTICE

- Do not employ a soft solder (materials that melt below 800°F (427°C)).
- Do not remove the wet cloth until all brazing is completed.

! WARNING

Fire, Explosion and Personal Safety Hazard.

Do not use oxygen to pressurize or purge refrigerant lines. Oxygen can react when exposed to sparks and cause fires or explosions.

Brazing the Refrigerant Line and the Filter Drier

All units are supplied with a bi-directional filter drier. Braze the filter drier to the liquid line, taking care not to push the refrigerant line too hard through the stop in the filter drier (doing so will damage the filter). The filter drier can be installed adjacent to the indoor or outdoor unit.

Braze the refrigerant lines to the service valves. Continue the dry nitrogen purge.

NOTICE

- Do not remove the wet cloth from the service valves and outdoor temperature sensor until all brazing is completed.
- Remove the wet cloth before stopping the dry nitrogen purge.

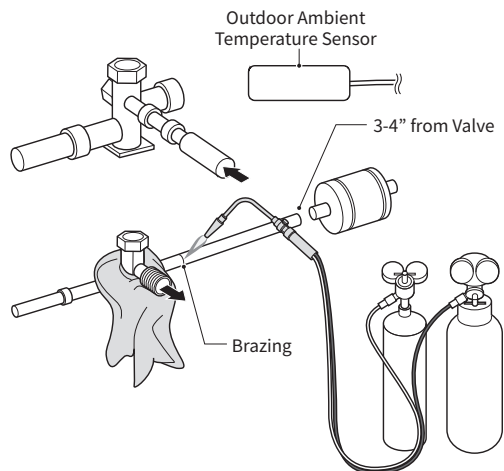

When replacing the bi-flow filter drier, refer to Product Replacement Parts List for the appropriate part number. You can purchase replacement filter driers from your local Navien distributor.

Outdoor Unit Connected to Factory Approved R-454B Indoor Unit

When the outdoor unit is connected to AHRI matched R-454B indoor unit, the outdoor unit contains the appropriate system refrigerant charge for operation with 25 ft. field-supplied or factory lineset tubing and the factory supplied bi-directional filter drier.

Crimping Line Connections

If using mechanical or crimp-type lineset connections, follow the crimp tool manufacturer's instructions.

Note If the use of mechanical fittings leads to the failure of the fittings or unit, such failure will not be covered under the unit's limited warranty.

Pressure Test for Gross Leaks

The refrigerant tubes and indoor coil should be pressure tested with an inert gas such as nitrogen. Pressurize the system with the inert gas to the Low Side Test Pressure listed on the outdoor unit rating plate.

Perform a pressure check of the unit with a nitrogen charge of 200 psi.

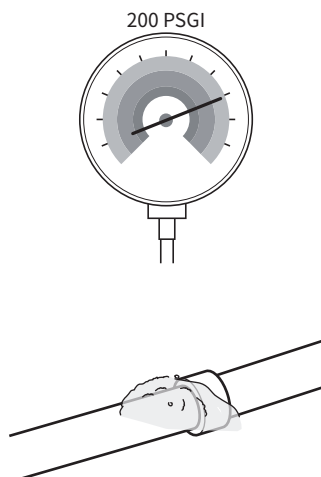

Use an approved leak check fluid that will not interfere with your electronic leak detector on each brazed joint to check for gross leaks.

The nitrogen holding charge must NOT decrease in pressure for 1 hour, as indicated by the test gauge. The measuring test gauge resolution not exceeding 5% of the holding charge.

Leak Check

The deep vacuum method requires a vacuum pump capable of creating a 500 micron vacuum and a vacuum gauge capable of accurately measuring the vacuum's depth. The deep vacuum method is the most positive way of assuring a system is free of air and non-condensables. A tight dry system will hold a vacuum of 1,000 microns after approximately 7 minutes.

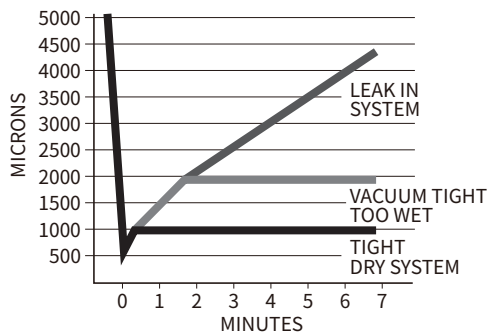
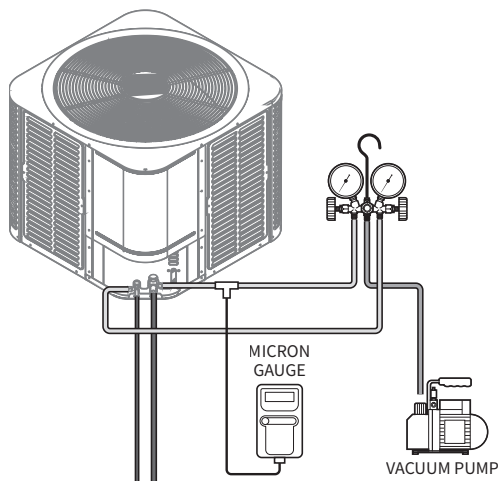

[Deep Vacuum Graph]

Evacuation

Use vacuum pump and gauge approved for use with R454B.

1. Connect the manifold gauge set to the service valve ports as follows:
 - Low pressure gauge to vapor line service valve
 - High pressure gauge to liquid line service valve
2. Connect the micron gauge and the vacuum pump (with the vacuum gauge) to the center port of the manifold gauge set.
3. Open both the manifold valves and turn the vacuum pump on.
 - Evacuate until the micron gauge reading is no higher than 350 microns, then close off the valve to the vacuum pump.
4. Observe the micron gauge. Evacuation is complete, if the micron gauge does not rise above 500 microns in 1 minute and 1,500 microns in 10 minutes.
 - Once evacuation is complete, close the valves on the manifold gauge set, and then turn off the vacuum pump.

Opening the Service Valve

! WARNING

- Before opening the service valves, replace the valves cores. Then, the leak inspection and evacuation must be completed.
- The vapor service valve must be opened before the liquid service valve.
- When opening the liquid line service valve, extreme caution should be exercised. Failure to observe this warning will result in the release of system pressure, which could result in personal injury or property damage.

! WARNING

EXPLOSION HAZARD

Never use air or any gas containing oxygen for leak testing or operating the refrigerant compressors. Never allow compressor suction pressure to occur in a vacuum with the service valves closed.

1. Remove the valve cover from the vapor service valve and the liquid service valve.
2. Insert the hex wrench into the valve stem completely and slowly back out counterclockwise until the valve stem just touches the bead (about 5 turns).

NOTICE

Do not apply excessive force, and do not use power tools for actuating valves.

3. After each valve is fully opened replace the valve stem caps to prevent leakage. Tighten it with your fingers and turn it for another 1/6 turn using the appropriately sized wrench.
4. Repeat the same steps for the liquid line service valve.

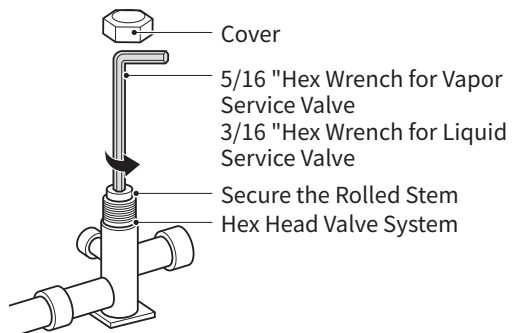

2.7 Connecting the Line Voltage

⚠ WARNING

ELECTRICAL SHOCK HAZARD

- Before installing, modifying, or servicing the system, the main electrical disconnect switch must be in the OFF position. There may be more than one disconnect switch. Lock out and tag the switch with a suitable warning label.
- The unit must be properly grounded in accordance with national and local codes.
- Before connecting the power supply, grounding is essential.

⚠ WARNING

Live Electrical Parts

- During the installation, testing, maintenance and troubleshooting of this product, it may be necessary to use live electrical parts. Failure to observe all electrical safety precautions when exposed to live electrical parts may result in death or serious injury.
- The high-voltage power supply must match the nameplate of the unit.

Be sure the field wiring complies with local and national fire, safety, and electrical codes, and the voltage to the system is within limits shown on the unit rating plate. See the unit rating plate for the recommended circuit protection device.

Operation of the unit on improper line voltage will affect unit reliability and the overall service life of the equipment. See the unit rating plate. Do not install the unit in a place where the voltage may fluctuate above or below permissible limits.

Use copper wire only between the disconnect switch and unit.

Note

- Install a branch circuit disconnect of adequate size per NEC, to handle the unit's starting current.
- Locate the disconnect within sight of the unit and have it readily accessible, per Section 440-14 of the NEC. Refer to Product Data for the breaker sizing.

Route Ground and Power Wires, remove the access panel to gain access to unit wiring. Extend the wires from the disconnect through the power wiring hole provided and into the unit control box.

Remove the terminal strip protective cover and connect the ground and connect power wires to L1 and L2 as marked. The power supply wiring must comply with national, state and local regulations. Follow the unit wiring diagram located on the back side of the control box access panel, refer to "5.3 Wiring Diagram" on page 44.

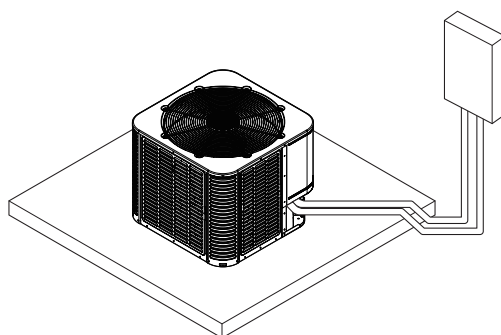
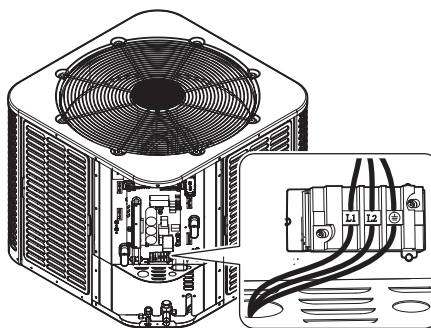

Control Wiring

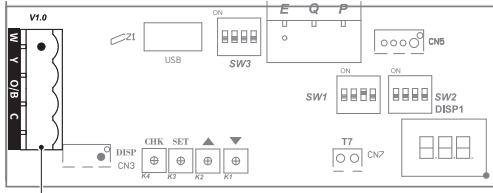

Low Voltage Terminal Block

Route the 24 V control wires through the control wiring grommet and connect the leads to the low voltage terminal strip. Refer to “5.1 Thermostat Wiring Diagram” on page 38 for specific unit combinations.

Max. Thermostat Wire Length	Thermostat Wire Gauge	Thermostat Wire Maximum Current
0-100 Ft	22	3.0 Amps
0-125 Ft	20	3.0 Amps
0-250 Ft	18	3.0 Amps

- Use the furnace transformer, fan coil transformer, or accessory transformer to provide power for control wiring (24VAC/40VA minimum). Make sure the available VA is adequate to support the total low voltage load.

Final Wiring Check

Referring to the unit nameplate, size the circuit, ensuring that the appropriate breaker is installed. Install a disconnect.

NOTICE

Check the factory wiring and field wire connections to ensure the terminations are secured properly. Check the wire routing to ensure that the wires are not in contact with the tubing, sheet metal, etc.

2.8 Unit Configuration

SW3 Capacity Model Selection

System software will recall the performance setting parameters according to the DIP switch selection. The DIP should be set according to the matched IDU.

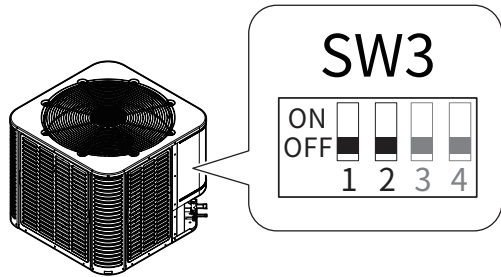

Model	Function	DIP Switch	
		SW3-1	SW3-2
NAA17V36	2 Ton	OFF	ON
	3 Ton	OFF	OFF
NAA17V60	4 Ton	ON	OFF
	5 Ton	ON	ON

2.9 Refrigerant Charging

2.9.1 System Charge

Check the outdoor ambient temperature. Subcooling (cooling mode) is the only recommended charging method when the outdoor ambient temperature is higher than 68°F (20°C). For outdoor ambient temperature below 68°F (20°C), use the weigh-in charging method.

2.9.2 Minimum Room Area Charging

The final refrigerant charging amount should be recorded on the outdoor unit charging label in permanent and easy-to-read writing. The total refrigerant charging amount of the system is the factory charging amount, plus or minus any refrigerant reclaimed or added based on the installation. Make sure that the indoor space provided by the indoor unit, including the ducted space, exceeds the minimum indoor size listed on the outdoor unit charging label.

Total Refrigerant Amount of System (lbs)	Minimum Floor Area (ft ²)
7	106
8	122
9	137
10	152
11	167
12	182
13	198
14	213
15	228
16	243
17	258
18	274

2.9.3 Refrigerant Charging: Subcooling Method

The only mode approved for verifying system charging is in "forced cooling mode".

The outdoor temperature must be between 68°F (20°C) and 113°F (45°C), and the indoor temperature should be between 68°F (20°C) and 89°F (31.7°C). (The recommended indoor temperatures are between 70°F (21.1°C) and 80°F (26.7°C).)

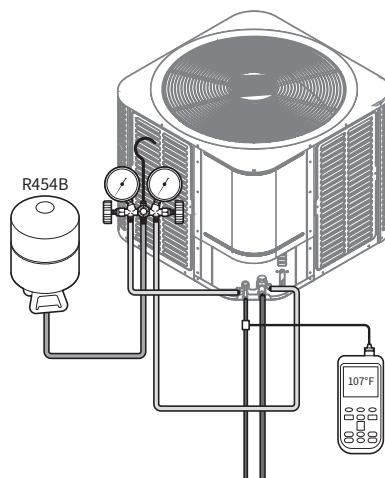

2.10 System Startup

1. Set the system thermostat to off.
2. Turn on the disconnect switch and apply power to indoor unit and outdoor unit.

NOTICE

When starting the unit for the first time and the outdoor temperature is below 70°F (21.1°C), it is recommended to power on and let the crankcase heater preheat for 1 hour before turning on the unit.

3. Turn on the thermostat and set to COOL, adjusting the set temperature below indoor temperature. On the control board, press and hold "SET" until "dC" displayed to start/quit "forced cooling" mode.

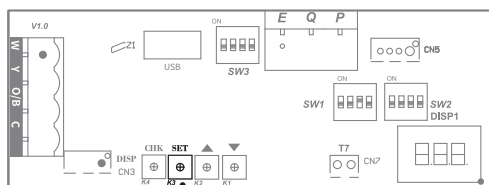

SET (K3) Switch

4. Allow the system to run and stabilize, approximately 20 minutes after "forced cooling" mode has started.
 - The compressor will maintain a compressor and fan speeds in "forced cooling" mode.
5. Calculate the subcooling value with the measured liquid line temperature and high side pressure.
 - If the calculated subcooling value is lower than the designed subcooling value, using the manifold gauge set still attached to the unit refrigerant should be added. Refer to the subcooling table on page 27.
 - If the calculated subcooling value is higher than the value, refrigerant should be recovered.

6. After adjusting the charge, wait again for the system to stabilize.
 - Wait for 5 minutes, reevaluate the charge, and adjust it as many times as needed so the charge is correct and the subcooling values match the designed subcooling value in the table below:

Subcooling – Liquid Line Temperature and Gauge Pressure								
Liquid Line Temp (°F)	Subcooling Value (°F)							
	6	7	8	9	10	11	12	13
	Liquid Gauge Pressure (PSI)							
55	164	167	170	172	175	178	181	184
60	178	181	184	187	191	194	197	200
65	194	197	200	203	206	210	213	217
70	210	213	217	220	223	227	230	234
75	227	230	234	238	241	245	249	252
80	245	249	252	256	260	264	268	272
85	264	268	272	276	280	284	288	292
90	284	288	292	297	301	305	309	314
95	305	309	314	318	323	327	332	336
100	327	332	336	341	346	351	355	360
105	351	355	360	365	370	375	380	385
110	375	380	385	390	396	401	406	412
115	401	406	412	417	422	428	433	439
120	428	433	439	445	450	456	462	468
125	456	462	468	474	480	486	492	498

Subcooling – Ambient Temperature and Air Conditioner Capacity						
Subcooling (°F)		Ambient Temperature (°F)				
		68-77	77-86	86-95	95-104	104-113
Model	NAA17V36	10±2	8±2	8±2	6±2	6±2
	NAA17V60	8±2	8±2	8±2	6±2	6±2

Subcooling – Liquid Line Temperature and Gauge Pressure								
Liquid Line Temp (°C)	Subcooling Value (°C)							
	3.3	3.9	4.4	5.0	5.6	6.1	6.7	7.2
	Liquid Gauge Pressure (kg/cm ²)							
12.8	11.53	11.74	11.95	12.09	12.30	12.51	12.73	12.94
15.6	12.51	12.73	12.94	13.15	13.43	13.64	13.85	14.06
18.3	13.64	13.85	14.06	14.27	14.48	14.76	14.98	15.26
21.1	14.76	14.98	15.26	15.47	15.68	15.96	16.17	16.45
23.9	15.96	16.17	16.45	16.73	16.94	17.23	17.51	17.72
26.7	17.23	17.51	17.72	18.00	18.28	18.56	18.84	19.12
29.4	18.56	18.84	19.12	19.40	19.69	19.97	20.25	20.53
32.2	19.97	20.25	20.53	20.88	21.16	21.44	21.72	22.08
35.0	21.44	21.72	22.08	22.36	22.71	22.99	23.34	23.62
37.8	22.99	23.34	23.62	23.97	24.33	24.68	24.96	25.31
40.6	24.68	24.96	25.31	25.66	26.01	26.37	26.72	27.07
43.3	26.37	26.72	27.07	27.42	27.84	28.19	28.54	28.97
46.1	28.19	28.54	28.97	29.32	29.67	30.09	30.44	30.86
48.9	30.09	30.44	30.86	31.29	31.64	32.06	32.48	32.90
51.7	32.06	32.48	32.90	33.33	33.75	34.17	34.59	35.01

Subcooling – Ambient Temperature and Air Conditioner Capacity						
Subcooling (°C)		Ambient Temperature (°C)				
		20-25	25-30	30-35	35-40	40-45
Model	NAA17V36	5.6±1.1	4.4±1.1	4.4±1.1	3.3±1.1	3.3±1.1
	NAA17V60	4.4±1.1	4.4±1.1	4.4±1.1	3.3±1.1	3.3±1.1

2.10.1 Refrigerant Charging: Weigh-In Method

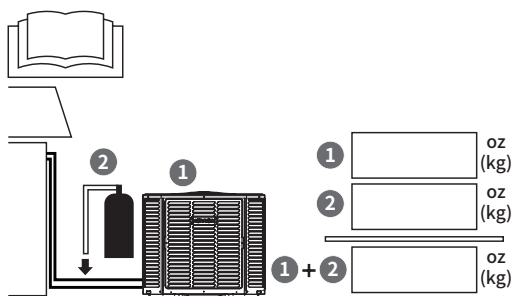

Use the weigh-in method anytime a system charge is being replaced or when power is not available at the equipment site or the operating conditions (indoor/outdoor temperatures) are not within the range for verification using the subcooling charging method.

The factory charge in the outdoor unit is sufficient for 25 ft of standard size liquid line. Additional 0.54 oz/ft refrigerant is needed when the length of the lineset is more than 25 ft.

New Installations — Calculating an additional charge for lineset greater than 25 ft.

1. Total length of line (ft) = _____ (a)
2. Standard line setup (ft) = 25 (b)
3. (a) minus (b) = _____ (c)
4. Refrigerant multiplier = 0.54 oz/ft (d)
5. Additional refrigerant quantity (c*d) = _____ (e)*

* If the lineset is less than 25 feet, e=0

Sealed-System Repairs — Calculating the total system charge.

1. Total length of line (ft) = _____ (a)
2. Standard line setup (ft) = 25 (b)
3. (a) minus (b) = _____ (c)
4. Refrigerant multiplier = 0.54 oz/ft (d)
5. Additional refrigerant quantity (c*d) = _____ (e)*
6. Factory filling quantity (nameplate) = _____ (f)
7. Total system charge (e + f) = _____

* If the lineset is less than 25 feet, e = 0

When the weigh-in method is used, verify subcooling at a later time when ambient temperature exceeds 68°F (20°C).

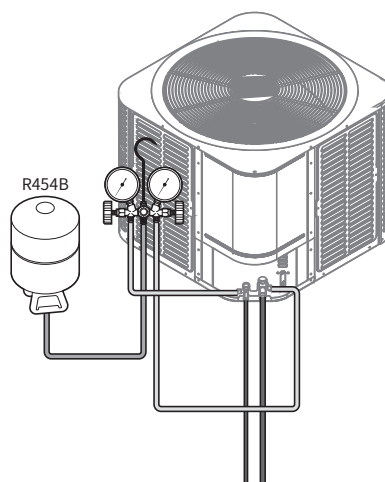

Charging is complete

When the charge is determined to be correct, remove the service tools, press and hold the "SET" button to quit "forced cooling" mode. Symbol "dC" should disappear when "forced cooling" mode has been exited. "Forced cooling" mode will automatically exit after 60 minutes or press and hold "SET" quit "forced cooling" mode manually.

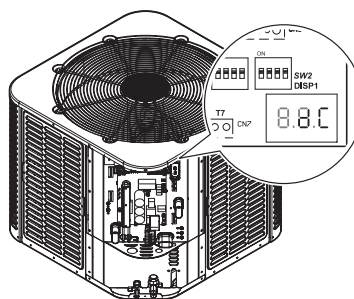

3. Installation Checklist

After installing the air conditioner and indoor unit, review the following checklist. You should be able to answer “Yes” to all of the items on the checklist. If not, review the appropriate sections to complete the installation.

If you have additional questions or need assistance with installation, contact Technical Support at 1-800-519-8794 or 1-949-420-0420, or refer to the technical support section of Navien’s website (www.navieninc.com).

Surrounding Environment Checklist	Yes	No
Is the vicinity of the fan free of any obstructions?		
Are the service panel and valves free of obstacles and obstructions?		
Are the drains of the indoor units clear and unobstructed?		

Installation Checklist	Yes	No
Is the unit properly located and the pad graded properly for drainage?		
Check for proper wire size and fuse/circuit breaker. Do they correspond to local codes for the recommended wire size and fuse/circuit breaker?		
All wiring connections are tight and properly secured, and the voltage and operating current are within the limits.		
All refrigerant lines are isolated, secured, and not in direct contact with each other or the structure.		
Check all braze connections for leaks. Record the adjusted refrigerant charge on a label next to the unit nameplate.		
Ductwork is sealed and insulated as needed.		
All drain lines are clear with the joints properly sealed. Pour water into the drain pan to confirm proper drainage.		
Check whether the capacity and operation mode settings of the DIP switch are correct.		
Cover panels are in place and properly tightened.		
Vapor and liquid line service valves should be fully open.		

4. Operating the System and Setting the DIP Switches

4.1 Control Logic Description

The Inverter system is compatible with conventional 24VAC controls.

The compressor's speed is controlled based on coil pressures monitored by the unit's pressure transducer. To ensure a stable and adequate capacity, the compressor speed will modulate relative to the suction pressure.

4.1.1 Accelerated Cooling

The DIP switch SW3-3 is set to the OFF position by default. If switch SW3-3 is set to ON, the target coil temperature will reduce. The accelerated cooling function improves the dehumidification capacity.

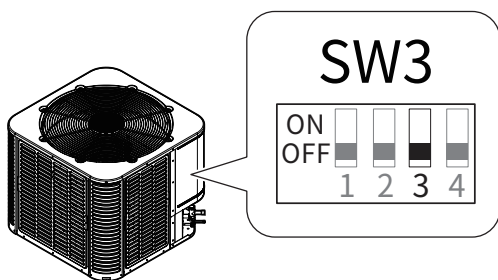

Switch	Function	Setting
3	Accelerated Cooling	3-ON
	Normal Cooling *(Factory Default)	3-OFF

4.2 SW1 DIP SWITCH Description

When the DIP switch SW1-1 default is OFF, this configures the unit to use a conventional one- or two-stage thermostat. This is the only available control method.

The DIP switch SW1-2 is for the selection of imperial or metric for the display temperature and units of measure for pressure.

Should a customer desire to change the air conditioner into a cooling only unit, the DIP switch SW1-3 is for switching to Cool Only(AC).

The DIP switch SW1-4 is for the USB Port Software Update function.

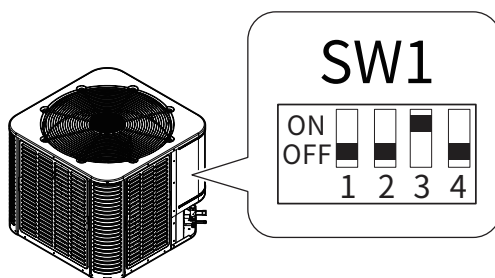

Switch	Function	Setting
1	RS485	1-ON
	24V thermostat *(Factory Default)	1-OFF
	°C & MPa	2-ON
	°F & PSI *(Factory Default)	2-OFF
	AC	3-ON
	-	3-OFF
	USB Port Software Update	4-ON
	Reserved *(Factory Default)	4-OFF

4.3 Compressor Crankcase Heater Control Function

The crankcase heater will be activated when any one of the following conditions is met.

- Discharge temperature is $T5 < 73.4^{\circ}\text{F}$ (23°C) when powered on for the first time.
- The power off time is longer than 3 hours or more than 2 hours when powered on for the first time. And at this time $T4 < 50^{\circ}\text{F}$ (10°C) and the discharge temperature is $T5 < 73.4^{\circ}\text{F}$ (23°C).
Exit conditions: Discharge temperature is $T5 \geq 82.4^{\circ}\text{F}$ (28°C).

T5: Compressor Discharge Temperature

- High discharge temperature/Low superheat protection

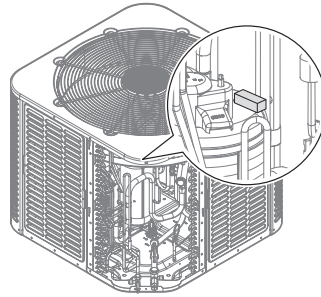

4.4 Sensors and Valves

T3: Outdoor Coil Temperature

- High temperature protection
- Outdoor fan control

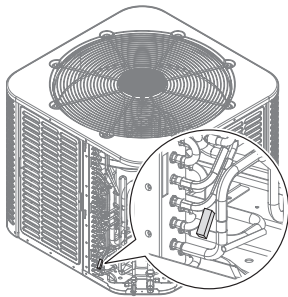

T7: Control Board Pipe Temperature

- Control Board Condensation Prevention

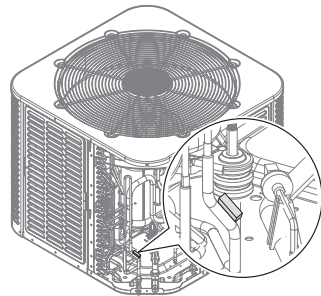

T4: ODU Ambient Temperature

- Maximum compressor frequency limitation

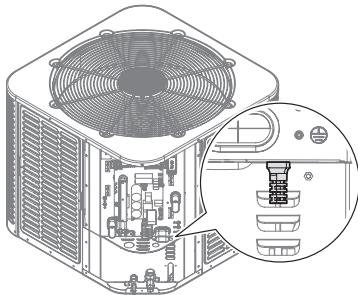

Tfin: IPM Condenser Temperature

- High IPM temperature protection

PT: Pressure Transducer

- Detect evaporating pressure.
- Compressor frequency control
- Low pressure protection

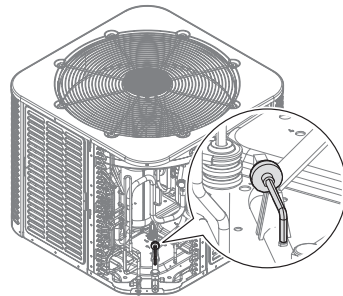

Pressure Equalizer Valve (PEV)

- Balance the pressure of the system before compressor start up

Temperature-Resistance Relationship Table (For T3, T4, T7 Sensors)							
Temperature (°F)	Temperature (°C)	Electric Resistance (kΩ)	Volt DC	Temperature (°F)	Temperature (°C)	Electric Resistance (kΩ)	Volt DC
-5	-20.6	33.367	0.57	90	32.2	3.865	2.63
0	-17.8	29.227	0.64	95	35.0	3.508	2.75
5	-15.0	25.657	0.72	100	37.8	3.187	2.87
10	-12.2	22.595	0.80	105	40.6	2.900	2.99
15	-9.4	19.942	0.89	110	43.3	2.652	3.09
20	-6.7	17.697	0.98	115	46.1	2.421	3.20
25	-3.9	15.673	1.08	120	48.9	2.214	3.30
30	-1.1	13.917	1.18	125	51.7	2.025	3.40
40	4.4	11.060	1.40	130	54.4	1.861	3.49
45	7.2	9.867	1.52	135	57.2	1.706	3.58
50	10.0	8.823	1.64	140	60.0	1.567	3.66
55	12.8	7.884	1.76	145	62.8	1.442	3.74
60	15.6	7.101	1.89	150	65.6	1.327	3.82
65	18.3	6.409	2.01	155	68.3	1.226	3.89
70	21.1	5.767	2.14	160	71.1	1.132	3.96
75	23.9	5.150	2.28	165	73.9	1.046	4.02
80	26.7	4.700	2.39	170	76.7	0.967	4.08
85	29.4	4.266	2.51				

Temperature-Resistance Relationship Table (for T5 sensor)							
Temperature (°F)	Temperature (°C)	Electric Resistance (kΩ)	Volt DC	Temperature (°F)	Temperature (°C)	Electric Resistance (kΩ)	Volt DC
-5	-20.6	496.38	0.08	140	60.0	12.348	1.97
0	-17.8	422.97	0.09	145	62.8	11.164	2.10
5	-15.0	361.35	0.11	150	65.6	10.106	2.22
10	-12.2	309.74	0.13	155	68.3	9.193	2.34
15	-9.4	266.152	0.15	160	71.1	8.344	2.46
20	-6.7	230.462	0.17	165	73.9	7.585	2.58
25	-3.9	198.968	0.19	170	76.7	6.904	2.69
30	-1.1	172.231	0.22	175	79.4	6.313	2.80
35	1.7	149.467	0.26	180	82.2	5.761	2.92
40	4.4	130.642	0.29	185	85.0	5.263	3.02
45	7.2	113.87	0.33	190	87.8	4.815	3.13
50	10.0	99.456	0.37	195	90.6	4.410	3.23
55	12.8	87.095	0.42	200	93.3	4.057	3.33
60	15.6	76.425	0.48	205	96.1	3.724	3.42
65	18.3	67.501	0.53	210	98.9	3.423	3.51
70	21.1	59.457	0.60	215	101.7	3.149	3.60
75	23.9	52.489	0.67	220	104.4	2.910	3.67
80	26.7	46.429	0.74	225	107.2	2.689	3.75
85	29.4	41.322	0.82	230	110	2.476	3.82
90	32.2	36.682	0.90	235	112.8	2.288	3.89
95	35.0	32.619	0.99	240	115.6	2.117	3.96
100	37.8	29.068	1.09	245	118.3	1.965	4.02
105	40.6	25.948	1.19	250	121.1	1.821	4.08
110	43.3	23.291	1.29	255	123.9	1.690	4.13
115	46.1	20.855	1.39	260	126.7	1.569	4.19
120	48.9	18.708	1.51	265	129.4	1.462	4.23
125	51.7	16.809	1.62	270	132.2	1.360	4.28
130	54.4	15.184	1.73	275	135.0	1.266	4.32
135	57.2	13.682	1.85	280	137.8	1.180	4.36

4.5 System Protection

4.5.1 Protection Function

Temperature protection for outdoor coils (T3)

- If T3 > Maximum set temperature (147°F (64°C)), the system will stop until T3 temperature reaches recovery temperature.
- If T3 < the set recovery temperature (135°F (57°C)), the system will restart.

Compressor discharge temperature protection (T5)

- If the temperature is higher than the set maximum value, the system will stop until T5 temperature reaches recovery temperature (194°F (90°C)).
- If the temperature is lower than the set recovery temperature (194°F (90°C)), the system will restart.

4.5.2 Error Codes

The following table lists the error codes and their descriptions.

Code	Failure or Protection Definition
F0	Communication failure (outdoor unit)
F1	Low pressure switch error
F4	T4 outdoor ambient temp sensor error
F5	T5 compressor discharge temp sensor error
F6	T3 condensing temp sensor error
F7	T7 temp sensor error
F8	T7 temp sensor error in detecting condensate risks
F9	AC overvoltage/undervoltage protection
FA	EEPROM failure (outdoor unit)
FB	EEPROM failure of driver chip
FC	IPM modular sensor error
FD	HLP pressure sensor failure
FE	T3 or T5 sensor disconnect error
FF	HPS condenser sensor disconnected
P1	High pressure switch error
P2	Low pressure protection
P3	Inverter overcurrent protection

Code	Failure or Protection Definition
P4	T5 compressor discharge temp sensor high temp protection
P5	T3 condenser sensor high temp protection
P6	IPM protection
P8	IPM high temperature protection (Ft)
P9	DC fan motor error
PC	PC Wet operation error
H0	Communication fault of master board and driver chip
H1	T3 sensor high temperature error (3 times P5 error within 180 mins)
H2	High pressure switch error (3 times P1 error within 150 mins)
H4	IPM modular high temp error (3 times P8 within 120 mins)
H5	Low pressure error (5 times P2 within 240 mins)
H6	Discharge temperature abnormal error (3 times P4 within 100 mins)
H7	Moisture exposure operation error (3 times PC within 200 mins)
H8	T3 condenser sensor disconnect error (3 times FE within 120 mins)
HC	Discharge temp sensor disconnect error (3 times FE within 180 mins)
HE	Condensate error (3 times within 60 mins)
L0	DC cable bus low voltage protection
L1	DC cable bus high voltage protection
LA	Frequency limitation by voltage
LB	Frequency limitation or decline by high pressure
LC	Frequency limitation by condenser temp
LD	Frequency limitation by discharge temp
LE	Frequency limitation by IPM modular high temp
LF	Frequency limitation by current
d0	Running indication under oil return mode
dC	Running indication under force cooling mode
ATL	Overtemperature protection
PRH	Crankcase heater in progress, no start-up

4.5.3 Parameter Point Check Table

To display system parameters, press the “CHK”(K4) button to run through the series of parameters available. The first time you press the “CHK” button, it will display the NUM of the parameter, and after 1 second it will display the value of the parameter. If you press the “CHK” button again, it will go to the next NUM of the parameter.

- ▲: Check button, and set the parameter “+”
- ▼: Check button, and set the parameter “-”

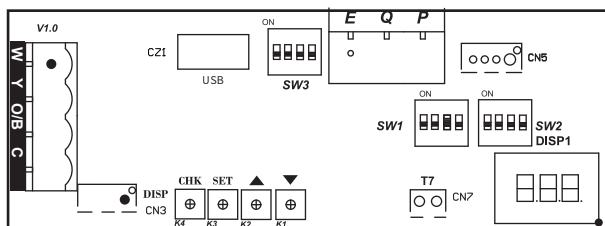

#	Description	#	Description
00	Unit type 0: Top discharge unit	20	AC amperage (A; Actual value)
01	Outdoor unit mode (Model)	21	Compressor amperage
02	Running mode 0: Standby mode 2: In cooling mode	22	Oil discharge amount (CC; Actual value)
03	Target frequency (Hz; Actual value)	23	Reserved
04	Actual frequency (Hz; Actual value)	24	Reserved
05	Running frequency (Hz; Actual value)	25	Reserved
06	T3 outdoor coil temp (°F; Actual value)	26	Enter PI control sign (0 or 1)
07	T4 outdoor ambient temp (°F; Actual value)	27	Reserved
08	T5 compressor discharge temp (°F; Actual value)	28	Test mode (1-40; Mode gear)
09	Temp transform by pressure sensor (°F; Actual value)	29	Frequency increase (Shift; Actual value)
10	IPM modular temp Tfin (°F; Actual value)	30	Reserved
11	Target temp Tes/Tcs (°F; Actual value)	31	PFC control state
12	Discharge temp superheat (°F; Actual value)	32	Frequency limit item
13	Target superheat (°F; Actual value)	33	Driving failure code subdivision1
14	Fan speed (Actual value/10)	34	Driving failure code subdivision2
15	Reserved	35	Last failure or protection code
16	Pressure valve (PSI; Actual value)	36	Software version number (1-255)
17	Pressure valve transform by T3 (PSI; Actual value)	37	T7 condensing temp (°F; Actual value)
18	AC voltage (VAC; Actual value)	38	T30 temp (°F; Actual value)
19	DC voltage (VDC; Actual value)	39	Compression ratio

4.6 Care and Maintenance

For continued high performance and minimizing possibility of equipment failure, annual maintenance must be performed on this equipment. The frequency of maintenance may vary depending on your geographic areas.

Precautions

WARNING

Any maintenance and cleaning of outdoor units can only be carried out by qualified maintenance personnel.

WARNING

Electric Shock

- Disconnect the power before repairing or changing the electrical wiring.
- When servicing the unit control, label all wires before disconnecting them. Wiring errors can lead to improper and dangerous operation.
- Disconnect all electric power supplies before opening the access panel.
- Wait five minutes before servicing to allow electrical components to discharge. Should never forcibly discharge the capacitors.

CAUTION

Contains High Pressure Refrigerant

The system contains high pressure oil and refrigerant. Before opening the system, recover the refrigerant to release the pressure.

CAUTION

- Do not use chemicals or chemically treated cloth to clean the unit.
- Do not use benzene, paint thinner, polishing powder or other solvents to clean this unit.

Repairing Refrigerant Circuit

When opening the refrigerant circuit to make repairs, or for any other purpose, the following procedures must be used:

- Safely recover the refrigerant using a recovery pump certified for flammable refrigerants.
- Purge the refrigerant circuit with nitrogen gas.
- Evacuate the refrigerant circuit to 1,500 microns.

NOTICE

- Open the circuit by cutting or brazing.
- Break the vacuum with a nitrogen purge of the refrigerant circuit ensuring that the outlet of the vacuum pump is not near a potential ignition source.
- Replace the filter drier any time the refrigerant circuit is opened up.

Pre-Season Inspection and Maintenance

At the start of each cooling season, do the following:

- Turn off the unit and disconnect the power supply.
- Check for damaged wires and leaks.
- Clean indoor and outdoor coils as necessary.
- Clean the IDU drain pans.
- Check for proper airflows, and that condensate drains are clear.
- Check the air filters.

5. Appendixes

5.1 Thermostat Wiring Diagram

Dashed lines in the following thermostat wiring diagrams refer to optional wiring (wiring for Dehumidification, Electric Heater).

2H 2C Thermostat

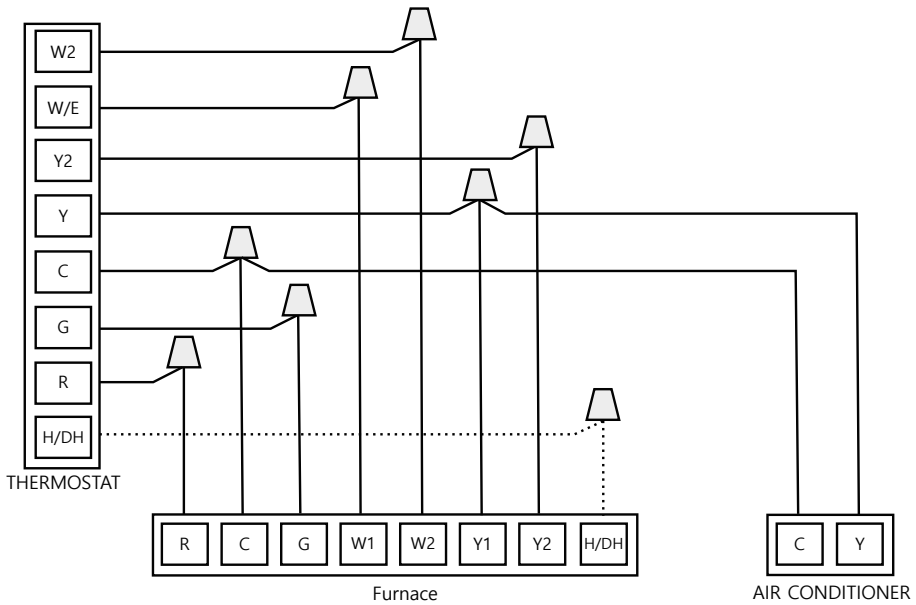
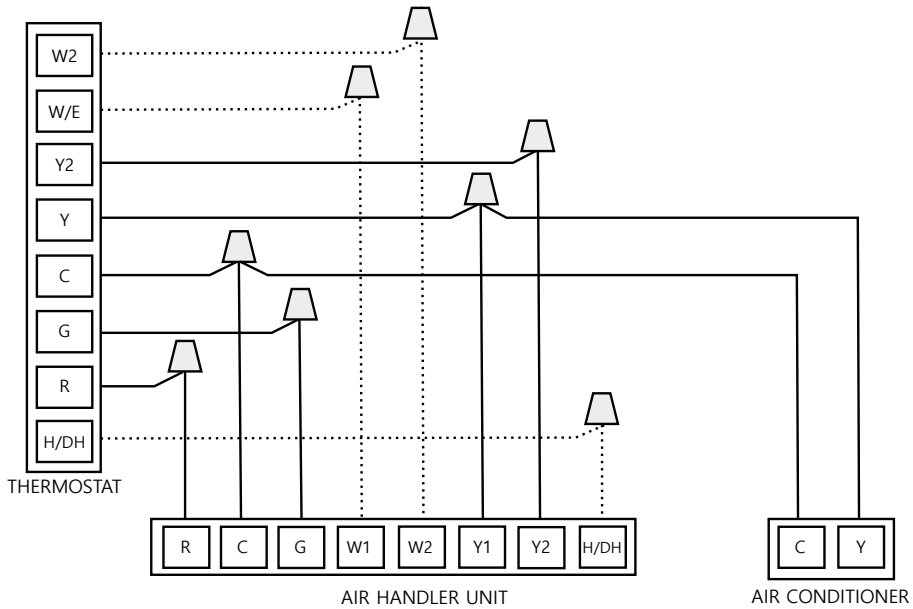

2H 1C Thermostat

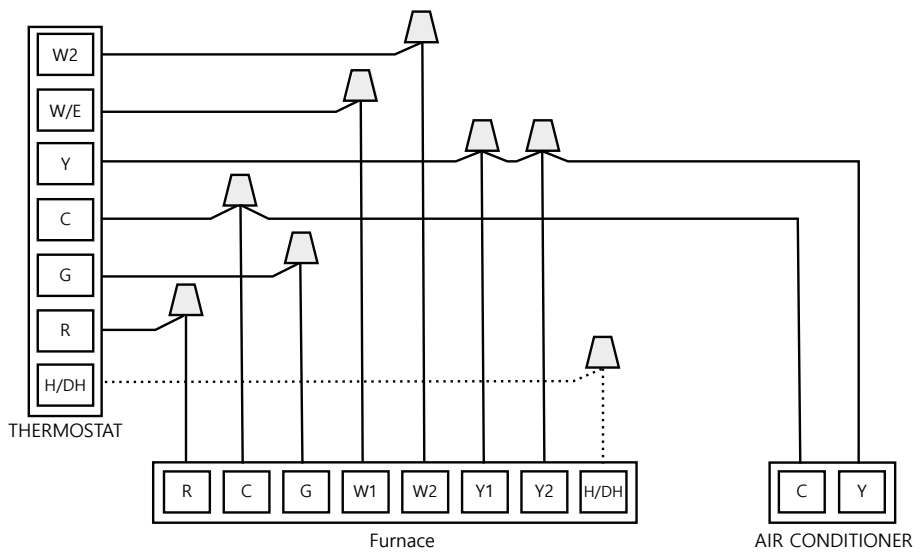
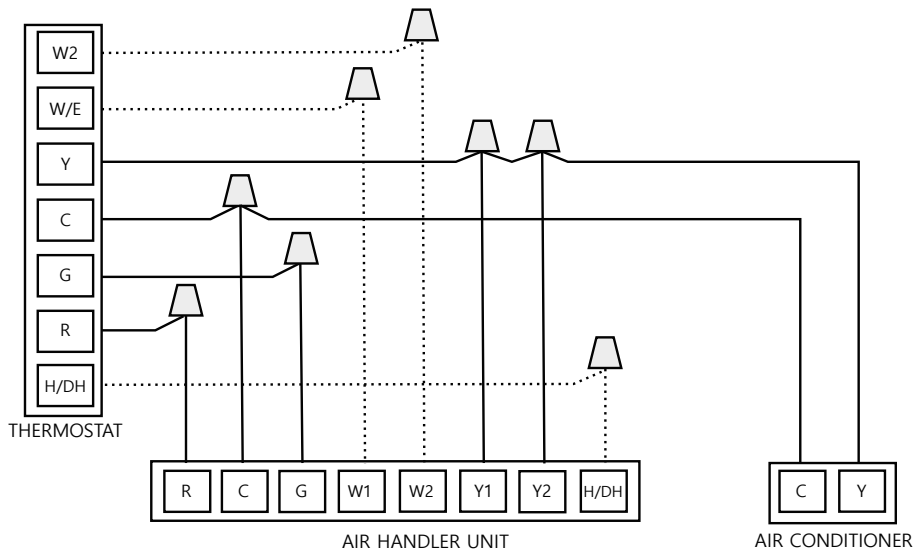

2C Thermostat

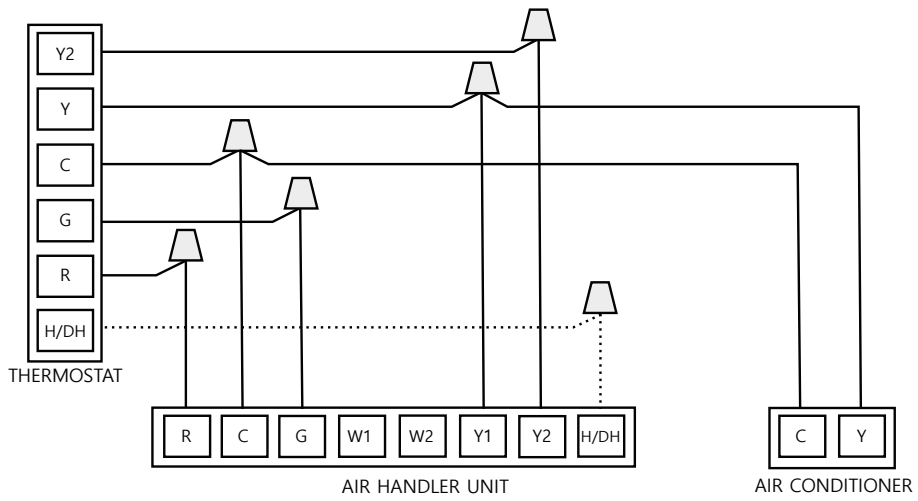

1C Thermostat

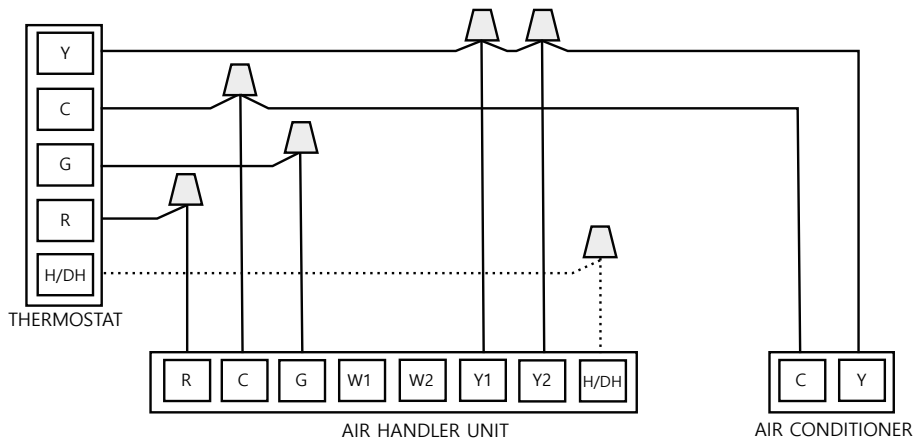

1H 1C Thermostat

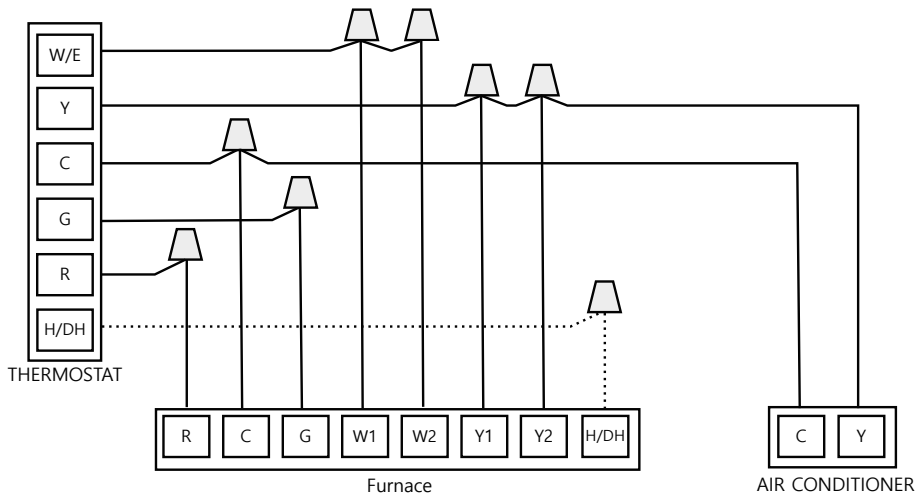

5.2 Overview of Main Control Board

NAA17V36 Air Conditioner Main Control Board

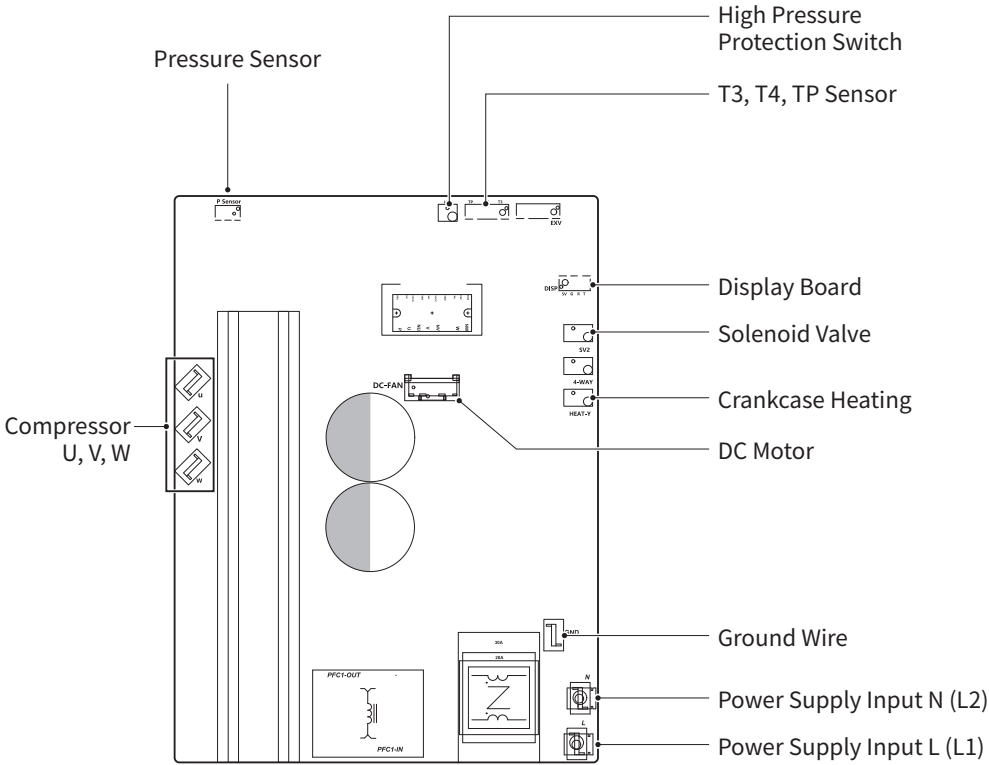

NAA17V60 Air Conditioner Main Control Board

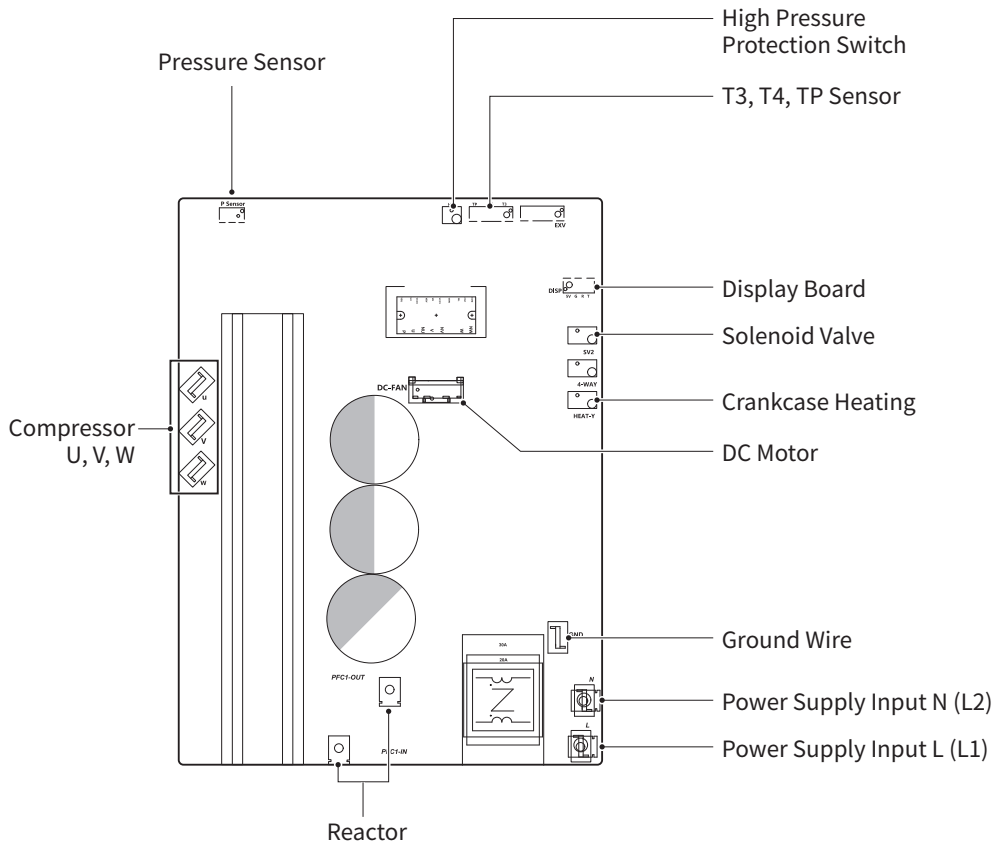

Air Conditioner Display Board

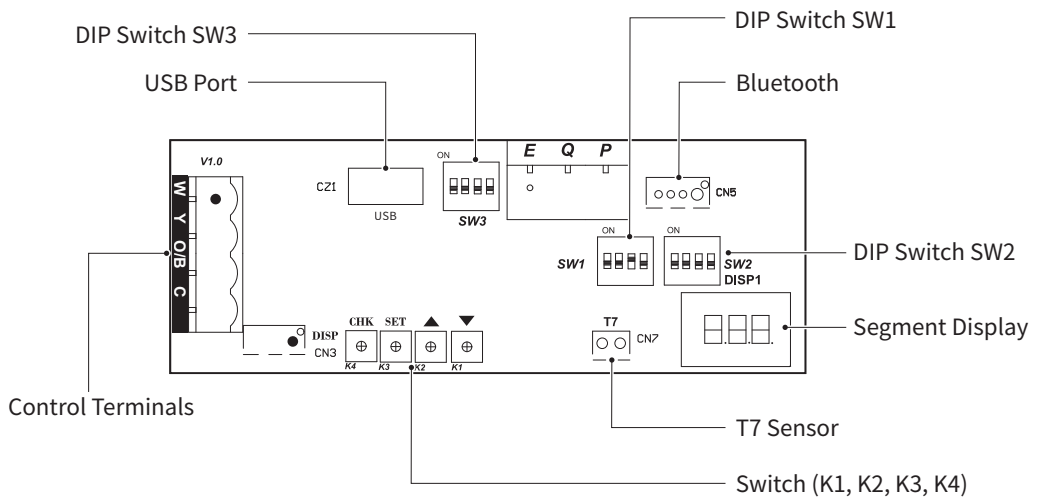

5.3 Wiring Diagram

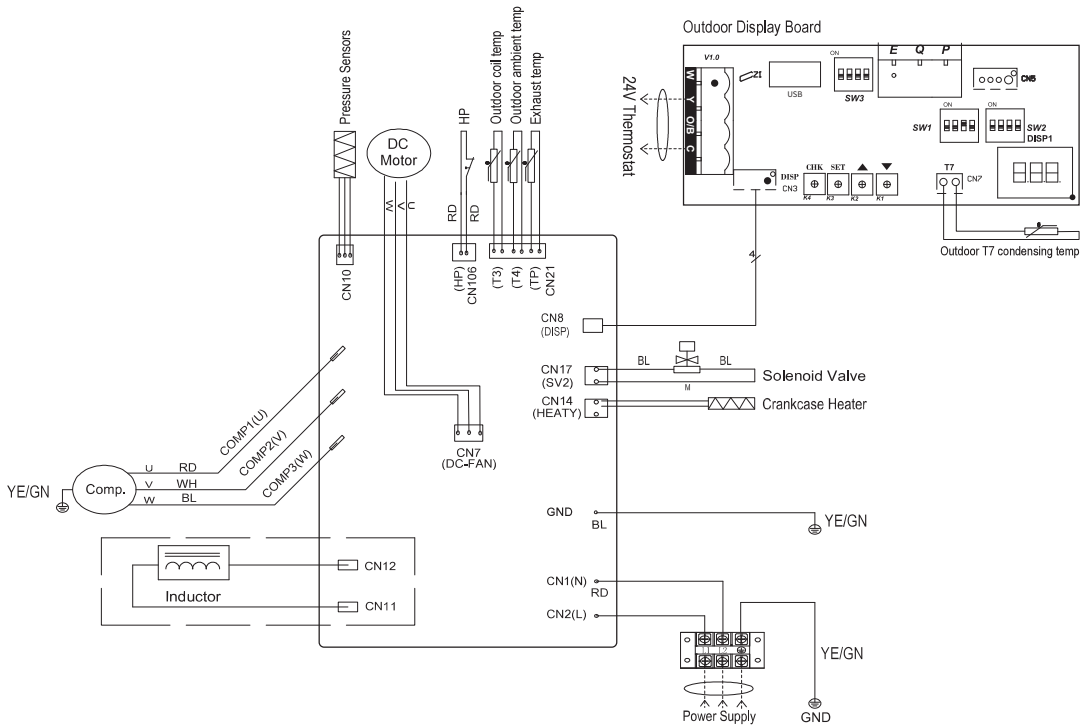

Factory Settings			
Switch	Setting	Function	
1	1 – ON	Reserved	
	1 – OFF	24V control *(Factory Default)	
	2 – ON	Display temperature unit	°C, Mpa
	2 – OFF		°F, PSI *(Factory Default)
	3 – ON	Cooling only *(Factory Default)	
	4 – ON	USB upgrade (Contact factory personnel for operating instructions)	
	4 – OFF	Reserved *(Factory Default)	

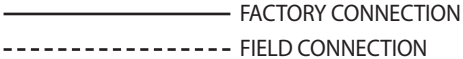
Factory Settings		
Switch	Setting	Function
3	1 – OFF / 2 - ON	NAA17V36 (2 Ton)
	1 – OFF / 2 - OFF	NAA17V36 (3 Ton)
	1 – ON / 2 - OFF	NAA17V60 (4 Ton)
	1 – ON / 2 - ON	NAA17V60 (5 Ton)
	3 – ON	Accelerated cooling
	3 – OFF	Normal cooling *(Factory Default)
Wire Color Code		Wire Information
Color	Code	 <p>————— FACTORY CONNECTION - - - - - FIELD CONNECTION</p>
BL	BLUE	
BK	BLACK	
BR	BROWN	
GN	GREEN	
GY	GRAY	
OR	ORANGE	
PR	PURPLE	
RD	RED	
WH	WHITE	
YE	YELLOW	

Note

- The wiring diagram is for explanation purposes only and the actual shape of the components may vary.
- When the DIP switch SW1-2 is set to “ON,” temperature and pressure will be displayed in SI units.

NOTICE

- If the DIP switch is set incorrectly or the cables are improperly connected to the PCB, the air conditioner may not operate properly.
- Please read and follow the manual completely before using the product.

6. LIMITED WARRANTY NAVIEN, INC.

Effective

Navien products come with a limited warranty covering labor and parts, including the compressor. The following warranty periods begin from the date of original installation. The date of original installation must be provided to Navien, and upon request, proof of the original installation date must also be provided to Navien. When the product is installed in new construction, the commencement date shall be dated upon which the end-user takes title to the property.

If proof of the installation date is unavailable, then the original installation date shall be deemed to be six months after the unit's manufacture date. If the Product is registered online within 60 days of the Commencement Date, the base limited warranty term shall be extended from "Non-Registered" to "Registered" as shown in the Coverage Table. Any Product not properly registered online within 60 days of the Commencement Date shall be subject to the "Non-Registered" base limited warranty. You may register the unit and receive an email confirmation for your records at <https://www.navieninc.com/register>.

What is Covered?

Subject to the foregoing terms, Navien's only responsibility and the Purchaser's only remedy under this limited warranty, Navien will furnish a replacement part for installation by qualified HVAC service provider, without charge for the part only, to replace any Product part that fails due to a manufacturing defect under normal use and maintenance. Navien will repair or replace the covered part, if it is available, for a period of up to 10 years in regard to Parts¹. The Purchaser must pay for any and all shipping and handling charges and other costs of warranty service for the replacement part. Otherwise, if the Product part is not available, Navien will, at its option, a) provide a free suitable part or b) provide a credit in the amount of the then factory selling price for a new suitable substitute part to be used by the Purchaser towards the retail purchase price of a new Navien product. Any new Product purchase shall be at Purchaser's sole cost and expense including, but not limited to, all shipping, removal, and installation costs and expenses. Navien will pay labor charges for the repair subject to Navien's prior written approval and in accordance with Navien's schedule of approved labor allowances for a period of 90 days from the date of installation for the original owner only. All repair parts must be genuine Navien parts unless otherwise authorized by Navien. All repairs and replacements must be performed by an individual or servicing company that is qualified to do the type of repair. The replacement component or product will be warranted only for the unexpired portion of the applicable warranty period for the original component or Product. Warranty rights will not be diminished for residents of any jurisdiction, such as California and Quebec, that prohibit warranty benefits conditioned on registration.

Transfer of Warranty to Subsequent Owners

When ownership is transferred to a subsequent owner, while the Product remains at the site of original installation, warranties are reduced to the "Non-Registered" duration listed in the table below.

NAA17 – Coverage Table for Labor and Parts Only			
Residential ²			Commercial
Parts ¹	Registered ³	10 Years	1 Year
	Non-Registered ⁴	5 Years	
Labor	90 days		

Definitions:

Parts¹ – Refers to all internal functional components of the unit.

Residential² – Applies only to a single-family dwelling that services one (1) living unit. Any property converted or utilized to service two or more separate dwelling units, regardless of the municipal address, is automatically classified as a Commercial application and is subject to the reduced warranty period.

Registered³ – Refers to coverages for units registered within 60 days of the Commencement date.

Non-Registered⁴ – Refers to coverages for units registered 61 days or more after the Commencement Date; Secondary Owners.

How do I get service?

You must contact the original installer of your Product. Your installer will need to contact Navien to report the issue. If the original installer cannot be identified or you no longer choose to use that service provider, you may choose any service provider who is qualified to complete the necessary repair. Your service provider will need to contact Navien's Technical Support team at 800-519-8794 or an authorized Navien distributor prior to commencing any warranty service.

The installer and/or service provider must comply with Navien's warranty service and return policy procedures as available on Navien's website. During the applicable warranty period, replacement of the Product or Part requires Navien's direct prior written approval, and no third party is authorized to provide such approval on behalf of Navien.

Additional terms and conditions are continued on the reverse side.

Customer Name :	
Customer Address :	
Telephone :	Fax :
Email :	
Installer Name :	License No :
Installer Address :	
Place of Purchase :	
Model No :	
Serial No :	
Date of Purchase :	



Navien, Inc.
 20 Goodyear, Irvine, CA 92618
 Tel : 1-800-519-8794
 Fax : 949-420-0430
www.navieninc.com

For instant warranty registration, please register your product online at www.navieninc.com

What is not covered?

Navien's Limited Warranty shall be void in the event of an occurrence of any of the following:

- Improper installation, including but not limited to, installation in violation of applicable rules, laws or building codes, incorrect refrigerant type, reinstallation at another location, etc.
- Failure to install the unit by a qualified HVAC installer.
- Accident, abuse or misuse including but not limited to installation for non-recommended uses, failure to follow or comply with the Manual, etc.
- Improper maintenance including but not limited to, operating in corrosive atmospheric elements, including but not limited to, chlorine, fluorine, salt, sulfur, recycled waste water, urine, fertilizers, rust, or other damaging substances or chemicals.
- Modification, alteration, addition of non-approved components, or misapplication of the Product in any manner.
- Damage or problems caused by electrical surges, flooding, fire, freezing, abnormal external temperature, force majeure, riot, act of war, or any acts of God.
- Performance problems caused by improper use of refrigerant lines, filter drier, electric service voltage, wiring, fusing or any other components, parts or specifications.
- Vibration and noise unless caused by a defect in materials or workmanship. Any other causes other than defects in materials or workmanship.
- Operating the Product at temperatures outside the factory calibrated temperature limits and/or exceeding the maximum setting of the high limit control.
- Installation at any location outside the United States or Canada.
- Conversion from R-454B refrigerant to other refrigerants or attempt to operate with a type of refrigerant not specified for the air conditioner.
- Accidental or intentional damage.
- Failure to perform normal maintenance as described in the manual, such as cleaning of the heat exchangers, unit cleaning and/or filter replacement.
- Parts or accessories not supplied or designated by the manufacturer.
- Any damage, or the need for any repairs, caused by frozen or broken heat exchanger, moisture intrusion, mold or other biological growth.
- Changes in the appearance of the unit that do not affect its performance.
- Replacement of fuses and replacement or resetting of circuit breakers.
- Installation at any location outside the 50 States of the United States, the District of Columbia, and Canada.
- There is no warranty on any Product purchased through the internet or from any installer that obtained the Product from a supplier or distributor not authorized by Navien.

Warranty Limitations

EXCEPT AS EXPRESSLY PROVIDED HEREIN, THERE ARE NO OTHER WARRANTIES, EXPRESSED OR IMPLIED, INCLUDING, BUT NOT LIMITED TO WARRANTIES OR MERCHANTABILITY OR FITNESS FOR A PARTICULAR PURPOSE, WHICH EXTEND BEYOND THE DESCRIPTION OF THE WARRANTY HEREIN AND FURTHER NAVIEN SHALL NOT BE LIABLE FOR INDIRECT, INCIDENTAL, SPECIAL, CONSEQUENTIAL, PUNITIVE OR OTHER SIMILAR DAMAGES THAT MAY ARISE, INCLUDING LOST PROFITS, DAMAGE TO A PERSON OR PROPERTY, LOSS OF USE, INCONVENIENCE, OR LIABILITY ARISING FROM IMPROPER INSTALLATION, SERVICE OR USE OF THE PRODUCT. ANY IMPLIED WARRANTIES OF MERCHANTABILITY AND FITNESS ARISING UNDER STATE LAW ARE LIMITED IN DURATION TO THE PERIOD OF COVERAGE PROVIDED BY THIS WARRANTY, UNLESS THE PERIOD PROVIDED BY STATE LAW IS LESS.

No one is authorized to make any other warranties on behalf of Navien. Some states do not allow the exclusion or limitation of incidental or consequential damages, or how long an implied warranty lasts, so the above limitation may not apply to you.

This Limited Warranty gives you specific legal rights and you may also have other rights which vary from state to state. If this Product is considered a consumer product, please be advised that some local laws do not allow exclusions or limitations on incidental or consequential damages, or limitations on how long a warranty lasts; or how long an implied warranty lasts, so that the above limitations may not apply to you. Refer to your local laws for your specific rights under this limited warranty. If you have any questions regarding this limited warranty, please contact your original installation dealer, or any participating dealer, should your original installation dealer no longer be available. No action arising out of any claimed breach of this limited warranty may be brought by the Purchaser (or any subsequent purchaser retaining the balance of a properly transferred limited warranty) more than one (1) year after the cause of action or claim has arisen.

SKIP THE STAMP!



Use your camera to scan this QR code and register your unit online.

Retain this document for future reference.



For instant warranty registration, please register your product online at www.navieninc.com

Installation and Operation Manual

Navien Air Conditioner NAA Series (24K/36K/48K/60K, R454B)

Getting Service

If your air conditioner requires service:

- All repairs require pre-authorization by Technical Support.
- Request for your installer or any licensed professional to contact Technical Support at 1-800-519-8794 Option 2 once at the installation site.
- A short list of independent service providers in your area can be found on the website: www.navieninc.com/installers.
- Contact a licensed professional for the affected system (for example, a plumber, gas fitter, or electrician).

When you contact Technical Support, please have the following information at hand:

- Model number
- Serial number
- Date purchased
- Installation location and type
- Error code, if any appears on the front panel display

Version: 1.0 (January, 2026)



Navien, Inc.
800.519.8794 www.navieninc.com
20 Goodyear, Irvine, CA 92618