

Installation & Operation Manual

NFB700 Commercial Condensing Boilers

Model

- NFB700-500C
- NFB700-600C
- NFB700-800C
- NFB700-1000C



ALWAYS read and follow this manual completely before using the boiler. Save for future reference.



⚠ WARNING

If the information in these instructions is not followed exactly, a fire or explosion may result, causing property damage, personal injury, or death.

Do not store or use gasoline or other flammable vapors and liquids in the vicinity of this or any other appliance.

WHAT TO DO IF YOU SMELL GAS

- Do not try to light any appliance.
- Do not touch any electrical switch; do not use any phone in your building.
- Immediately call your gas supplier from a neighbor's phone. Follow the gas supplier's instructions.
- If you cannot reach your gas supplier, call the fire department.

Installation and service must be performed by a qualified installer, service agency or the gas supplier.

The installation must conform with local codes or, in the absence of local codes, the National Fuel Gas Code, ANSI Z223.1/NFPA 54 and/or CSA B149.1, ANSI/ASME CSD-1, Natural Gas and Propane Installation Code.

Contents

Important Safety Information	3	7. Connecting the Power Supply	76
1. About the Boiler	6	8. Installing a Cascade System	78
1.1 Included Items	6	8.1 Connecting Water Supplies	78
1.2 Accessories	6	8.2 Connecting the Communication Cables	84
1.3 Specifications	7	9. Installation Checklist	85
1.4 Components	9	10. Operating the Boiler	88
1.5 Dimensions	11	10.1 Operating the Boiler for the First Time	88
1.6 Rating Plate	13	10.2 Turning the Boiler On or Off	89
2. Installing the Boiler	14	10.3 Adjusting the Temperature	92
2.1 Choosing an Installation Location	14	10.4 About the Operating Status Information	93
2.2 Securing the Boiler to the Floor	17	10.5 Resetting the Boiler	94
2.3 Installing the Flue Gas Vent Kit and Vent Support Kit	17	10.6 Accessing Basic Menu Items	94
3. Installing the System Piping	19	10.7 Accessing Advanced Menu Items	102
3.1 Installing a Space Heating System	19	10.8 Understanding Error Codes	118
3.2 Connecting the Condensate Drain	28	11. Appendixes	120
3.3 Filling the System	32	11.1 Gas & High Altitude Conversion	120
3.4 Testing the Water System	34	11.2 Wiring Diagram	128
3.5 Considerations for System Applications	35	11.3 Outdoor Temperature Sensor	129
3.6 Examples of Electrical Connections	39	11.4 Outdoor Reset Control	129
3.7 Connecting External devices (Field Wiring Guidelines)	50	11.5 Requirements for the State of Massachusetts	131
4. Connecting the Gas Supply	53	11.6 Component Assembly Diagrams and Part Lists	132
4.1 Gas Pipe Sizing Tables	56	12. LIMITED WARRANTY NAVIEN, INC.	155
4.2 Measuring the Inlet Gas Pressure	57		
5. Venting for Combustion Air	59		
5.1 Venting the Boiler	60		
5.2 Selecting a Vent Type	62		
5.3 Selecting Vent Pipe Materials	66		
5.4 Measuring Vent Length	68		
5.5 Terminating the Vent	69		
5.6 Replacing the Air Filter	73		
6. Setting the DIP Switches	74		
6.1 DIP Switch 1 (6 switch unit)	74		
6.2 Dip Switch 2 (8 switch unit)	74		

Important Safety Information



The following Safety Alert Symbols are used in this manual. They are used to alert you to potential personal injury hazards. Obey all safety messages that follow this symbol to avoid possible serious injury or death. This Safety Alert Symbol precedes any safety message about risk of personal injury. It may also be accompanied by one of the following signal words.

If the information in these instructions is not followed exactly, a fire or explosion may result, causing property damage, personal injury or death.

DANGER

Indicates a hazardous situation that if not avoided will result in death or serious injury.

WARNING

Indicates a potentially hazardous situation that if not avoided could result in death or serious injury.

CAUTION

Indicates a potentially hazardous situation that if not avoided could result in minor or moderate injury.

NOTICE

Indicates information considered important but not hazard-related (such as property damage).

WARNING



If you smell gas:

- Do not try to light any appliance.
- Do not touch any electrical switches or use landline phones.
- From a neighbor's phone, call your gas provider and follow their instructions.
- If you cannot reach your gas provider, call the fire department.
- Do not return to your home until authorized by your gas supplier or the fire department.

Do not use or store flammable products, such as gasoline, solvents, or adhesives in the same room or area as the boiler.

- The boiler has a main burner flame that can turn on at any time and can ignite flammable vapors. Vapors from flammable liquids can explode and catch fire, causing death or severe burns.
- Vapors cannot be seen and are heavier than air. They can travel long distances along the ground and can be carried from other rooms to the boiler's main burner flame by air current.
- Keep all flammable products far away from the boiler and store them in approved containers. Keep the containers closed tightly and out of the reach of children and pets.

⚠ WARNING

To prevent death, serious injury, or property damage:

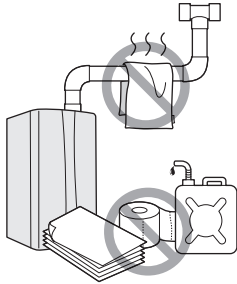

- **Shut off the gas supply if the boiler is damaged.**

Have your installer or plumber show you the location of the gas shut-off valve and demonstrate how to close the valve. If the boiler is damaged due to overheating, fire, flood, or any other reason, close the manual shut off valve and do not operate the boiler again until it has been inspected by a qualified technician.

- **Do not store or use gasoline or other flammable liquids near this boiler.**
Doing so may result in fire or explosion.
- **Do not place combustibles, such as newspapers or laundry, near the boiler or venting system.**
Doing so may result in a fire.
- **Do not place or use hair sprays, spray paints, or any other compressed gases near the boiler or venting system, including the vent termination.**
Doing so may result in fire or explosion.
- **Do not operate the boiler with the front cover open.**
Doing so may result in fire or carbon monoxide (CO) poisoning, which may lead to property damage, personal injury, or death.

⚠ WARNING

- **Do not operate this boiler without proper venting.**

Doing so may result in fire or carbon monoxide (CO) poisoning, which may result in property damage, personal injury, or death. Inspect the vent termination and air intake supply annually to ensure proper operation of the boiler. Turn off and discontinue use of the boiler if any of the vent pipes, vent elbows, or intake pipes are damaged in any way, separated at a joint, or show evidence of corrosion, rusting, or melting.

- **Do not touch the power cord or internal components of the boiler with wet hands.**
Doing so may result in electric shock.

California law requires the following Prop 65 warning to be provided:

⚠ WARNING

Cancer and Reproductive Harm -
www.P65Warnings.ca.gov

WARNING

To prevent death, serious injury, or property damage:

- **Do not turn on the boiler unless the water and gas supplies are fully opened.**
Doing so may damage the boiler.
- **Do not use this boiler for anything other than its intended purpose, as described in this manual.**
- **Do not remove the front cover unless the power to the boiler is turned off or disconnected.**
Failure to do so may result in electric shock.
- **When servicing the controls, label all wires prior to disconnecting them.**
Failure to do so may result in wiring errors, which can lead to improper or dangerous operation. Verify proper operation after servicing.
- **Do not use unapproved replacement or accessory parts.**
Doing so may result in improper or dangerous operation and will void the manufacturer's warranty.
- **Do not place anything in or around the vent terminals, such as a clothesline, that could obstruct the airflow in or out of the boiler.**
- **This boiler has been approved for use in the USA and Canada only.**
Using the boiler in any other country will void the manufacturer's warranty.
- **Should overheating occur or the gas supply fail to shut off, turn off the manual gas valve to the appliance.**

SAVE THESE INSTRUCTIONS

DANGER

Indicates a hazardous situation that if not avoided will result in severe injury or death.

WARNING

Indicates a hazardous situation that if not avoided could result in death or serious injury.

CAUTION

Indicates a potentially hazardous situation that if not avoided could result in minor or moderate injury.

NOTICE

Indicates information considered important but not hazard-related (such as property damage).









Product Installation Information

Model	
Date Purchased	
Gas Type	
Serial Number	

1. About the Boiler

1.1 Included Items

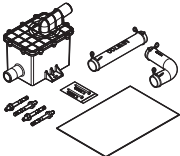
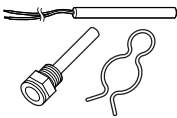
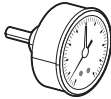
When you open the box, you will find the following items with the boiler. Check the box for each of the following items before installing the boiler.

	
Installation & Operation Manual, User's Information Manual	Quick Installation Manual
	
Air Vent	Pressure Relief Valve (50 psi)
	
Conversion Kit for High Elevation and Propane	Outdoor Temperature Sensor and Cable
	
Condensate Trap (with Condensate Hoses and Tapping Screws & Anchors)	Universal Temperature Sensor & Bulbwell Kit
	
Temperature and Pressure Gauge	Flue Gas Vent Kit

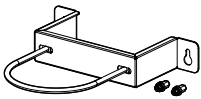
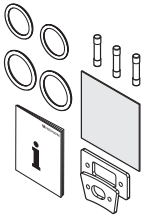
	
Vent Support Kit	Spare Parts Kit

1.2 Accessories

The following optional accessories are available for the boiler.

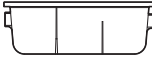
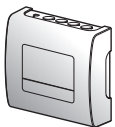
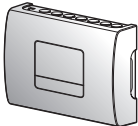
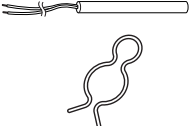
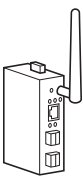
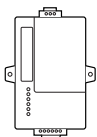
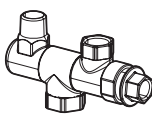
	
Light Commercial Neutralizer Kit (Optional Neutralizer Tank for Larger Cascade Systems)	Zone Controller (FMZ-20/30)
	
Zone Controller (4 or 6 Zones) (FMZ-40/60)	Universal Temperature Sensor (with Clip)
	
Modbus/BACnet Gateway & Power Adapter	LonWorks Gateway
	
Universal Adapter	

Note The universal temperature sensor can be used as a system temperature sensor or a DHW tank sensor.

1.3 Specifications

The following tables list the specifications for the boiler. Additional specifications for water, gas, electricity, and vent connections are provided in the Installation section.

Space Heating Specifications

Navien Commercial Condensing Boiler Space Heating Ratings						 Other Specifications		
Model Number ¹	Heating Input (MBH)		Gross Output ² (MBH)	Net AHRI Rating Water ³ (MBH)	Thermal Efficiency ² (%)	Boiler Water Content (Gallons)	Water Pressure	Water Connection Size Min. Max. (Supply, Return)
	Min.	Max.						
NFB700-500C	40	499	486	423	97.5	26.5	12-160 psi	2 in NPT
NFB700-600C	40	599	584	508	97.5			
NFB700-800C	66	799	779	677	97.5	37.0		2½ in NPT
NFB700-1000C	66	999	974	847	97.5			

Note

1. Ratings are the same for natural gas models converted to propane use.
2. Based on U.S. Department of Energy (DOE) test procedures.
3. The net AHRI water ratings shown are based on a piping and pickup allowance of 1.15. Consult Navien before selecting a boiler for installations having unusual piping and pickup requirements, such as intermittent system operation, extensive piping system, etc.

General Specifications

		NFB700-500C	NFB700-600C	NFB700-800C	NFB700-1000C
Dimensions		28.3 in (W) x 31.0 in (D) x 72.1 in (H)		28.3 in (W) x 33.0 in (D) x 73.3 in (H)	
Boiler Weight		622 lb (282 kg)		750 lb (340 kg)	
Boiler Weight with Water		843 lb (382 kg)		1059 lb (480 kg)	
Installation Type		Floor Standing			
Venting Type		Forced Draft Direct Vent			
Ignition		Electronic Ignition			
Natural Gas Supply Pressure (from source)		3.5 in-10.5 in WC			
Propane Gas Supply Pressure (from source)		8.0 in-13.0 in WC			
Natural Gas Manifold Pressure		-0.01 to -0.3 in WC		-0.01 to -0.5 in WC	
Propane Gas Manifold Pressure		-0.01 to -0.3 in WC		-0.01 to -0.2 in WC	
Gas Connection Size		1 in NPT		1¼ in NPT	
Power Supply	Main Supply	120 V AC, 60 Hz			
	Maximum Power Consumption	Less than 12 amperes			
Materials	Casing	Cold-rolled carbon steel			
	Heat Exchangers	Stainless Steel			
Venting	Exhaust	4 in PVC, CPVC, approved polypropylene, approved stainless steel 4 in Special Gas Vent Type BH (Class III, A/B/C)		6 in PVC, CPVC, approved polypropylene, approved stainless steel 6 in Special Gas Vent Type BH (Class III, A/B/C)	
	Intake	4 in PVC, CPVC, polypropylene, stainless steel 4 in Special Gas Vent Type BH (Class III, A/B/C)		6 in PVC, CPVC, polypropylene, stainless steel 6 in Special Gas Vent Type BH (Class III, A/B/C)	
Safety Devices		Flame Rod, APS, Water Temperature High Limit Sensor, Exhaust Temperature High Limit Sensor, LWCO (Low Water Cut Off), High Gas Pressure Switch, Low Gas Pressure Switch, Thermal Fuse			

Temperature Setting Range

Item		Temperature Setting Range	Remarks
Space Heating	Supply	77–190°F (25–88°C)	Actual supply and return temperatures vary depending on the selected outdoor reset curve.
	Return	68–158°F (20–70°C)	

Note

For more information about the space heating temperature setting range, refer to “10.6.2 Setting the Space Heating Operation” on page 95.

1.4 Components

The following diagram shows the key components of the boiler. Component assembly diagrams and particular parts lists are included in the Appendixes.

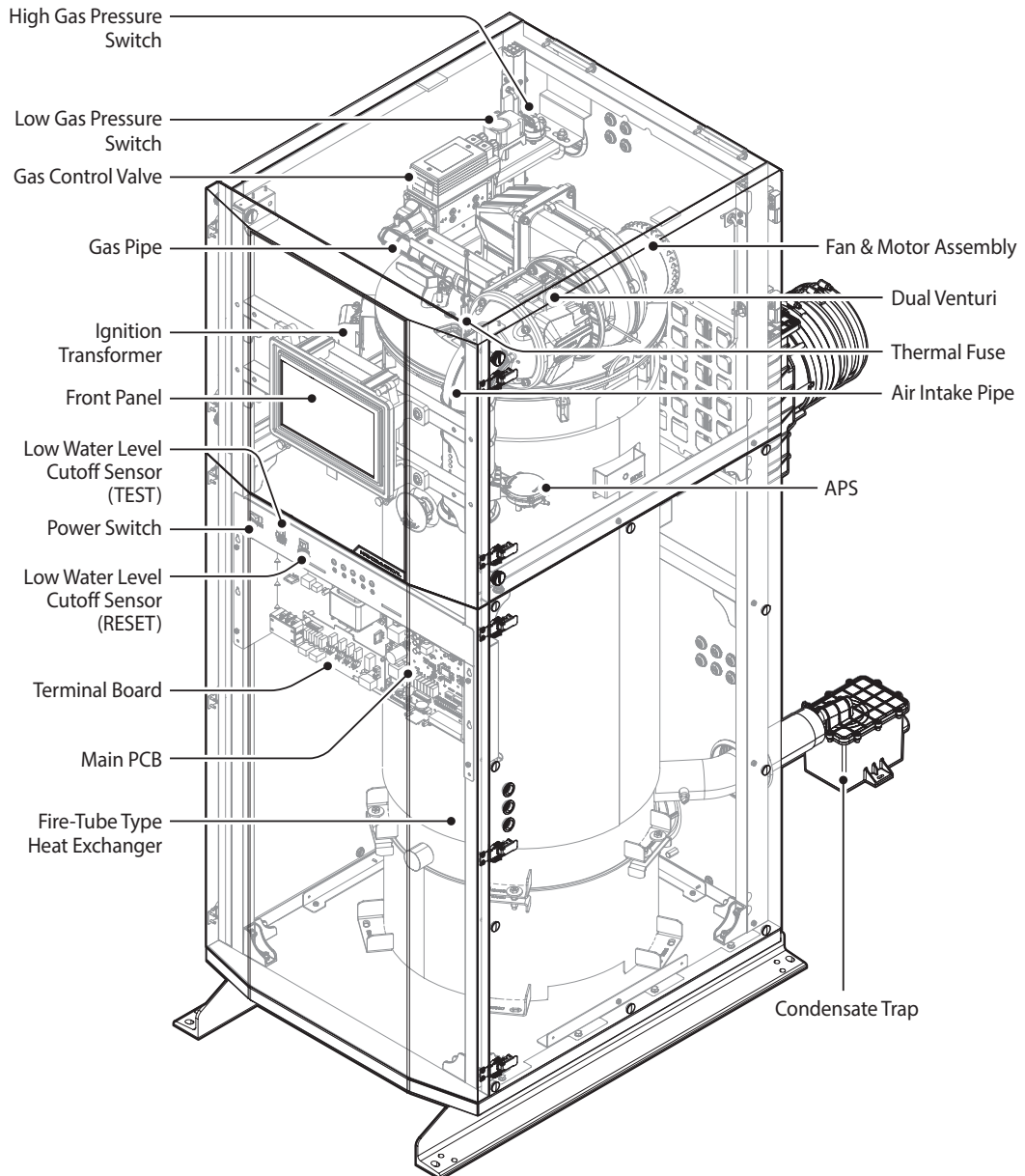

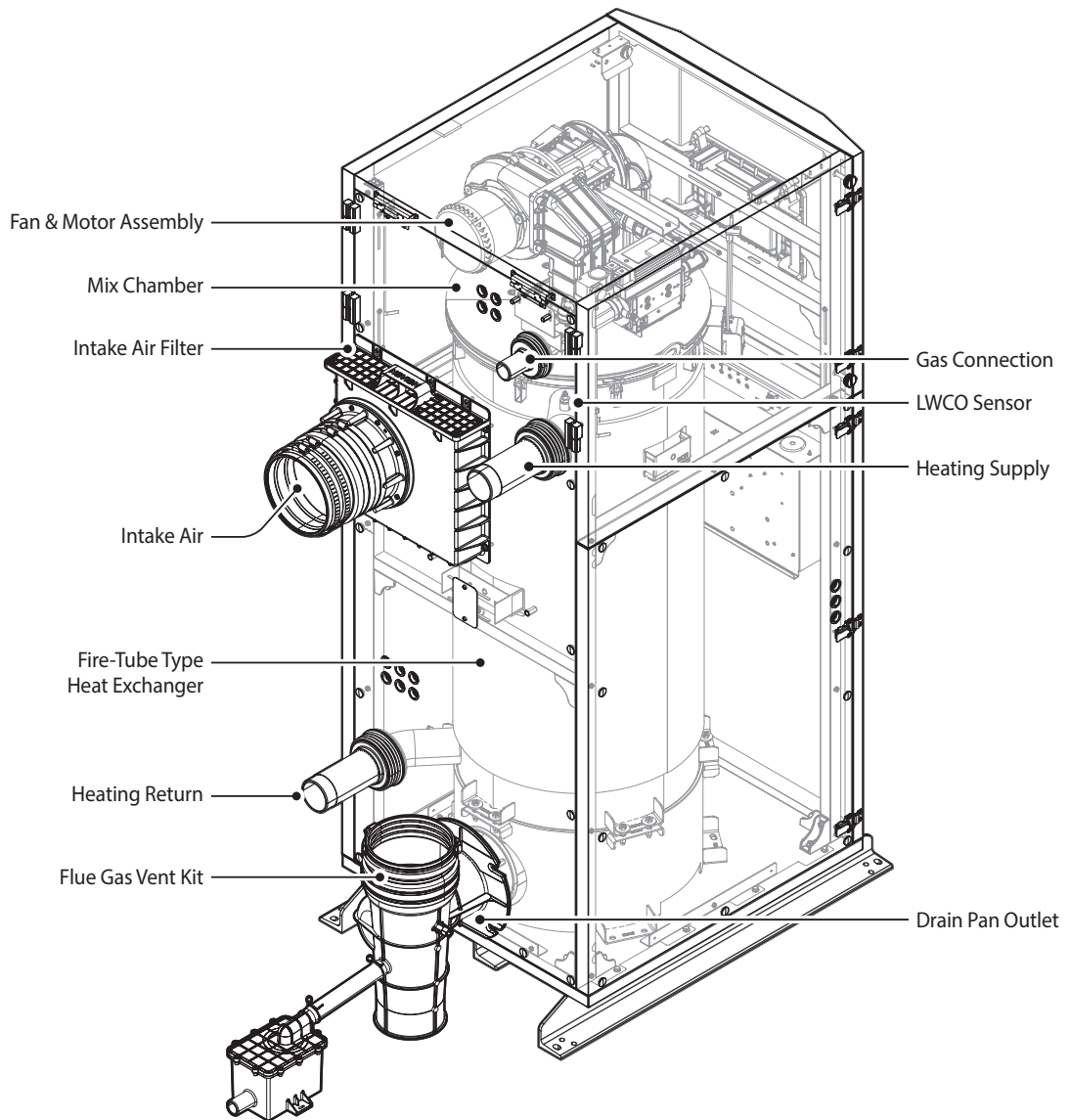

1.5 Dimensions

The following diagrams show the dimensions of the boiler and the table lists the supply connections.

Supply Connections

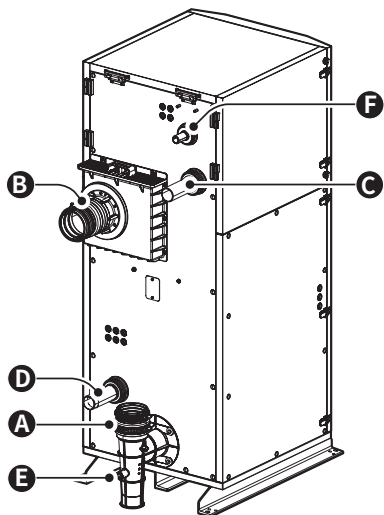

<NFB700-500C/600C>

Description		Diameter	
		NFB700-500C	NFB700-600C
A	Exhaust Gas Vent	4 in	
B	Air Intake	4 in	
C	Heating Supply	2 in (NPT)	
D	Heating Return	2 in (NPT)	
E	Condensate Outlet	1 in (NPT)	
F	Gas Connection	1 in (NPT)	

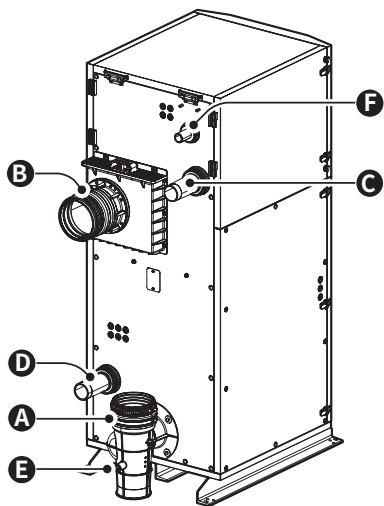

<NFB700-800C/1000C>

Description		Diameter	
		NFB700-800C	NFB700-1000C
A	Exhaust Gas Vent	6 in	
B	Air Intake	6 in	
C	Heating Supply	2 ½ in (NPT)	
D	Heating Return	2 ½ in (NPT)	
E	Condensate Outlet	1 in (NPT)	
F	Gas Connection	1 ¼ in (NPT)	

Rear View

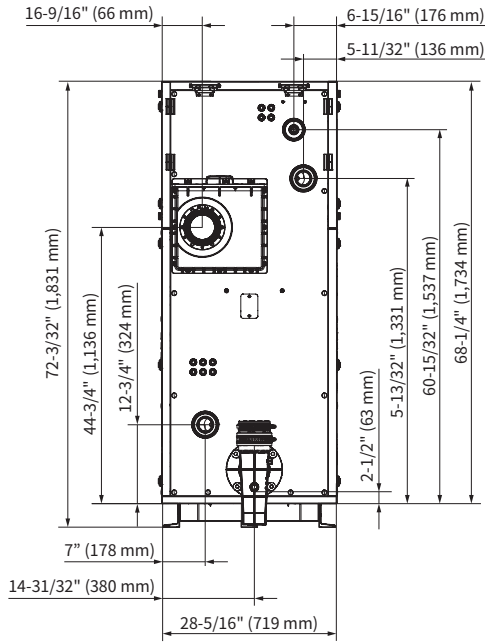

<NFB700-500C/600C>

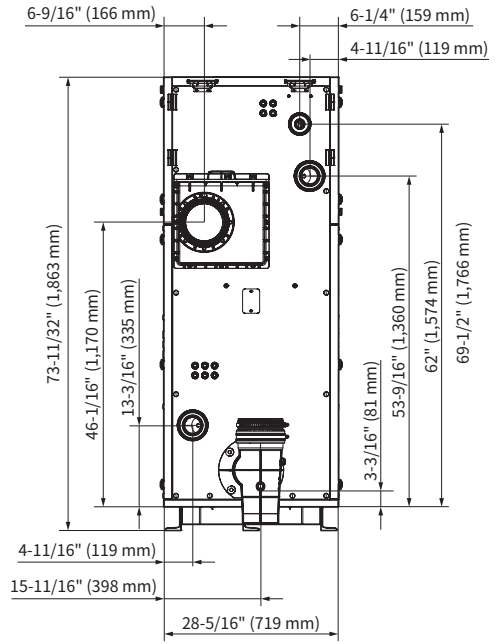

<NFB700-800C/1000C>

1.6 Rating Plate

The Navien NFB700 boilers come from the factory configured for use with Natural Gas (NG). If conversion to Propane Gas is required, the included Propane Gas & High Altitude Conversion Kit must ALWAYS be used. Refer to the Propane Gas & High Altitude Conversion Guide for more information.

Note The Propane Gas & High Altitude Conversion Kit is included in the accessory box. If you need assistance, please call a licensed professional or Navien Technical Support at 1-800-519-8794.

⚠ WARNING

To prevent death, serious injury or property damage:

Before starting the installation, check the Rating Plate located on the side of the boiler to ensure that the boiler matches the gas type, gas pressure, water pressure, and electrical supply available in the installation location.

If the boiler does not match each of these ratings, do not install the boiler. Using a different gas type will result in abnormal combustion and malfunction of the boiler.

- ONLY a licensed professional should connect the gas supply.
- ALWAYS leak test the appliance and the gas connections before operating the appliance.
- This boiler cannot be converted from natural gas to propane without a Navien Propane Gas & High Altitude Conversion Kit. NEVER attempt a field conversion of this boiler without using the Navien Propane Gas & High Altitude Conversion Kit. Doing so will result in dangerous operating conditions and will void the warranty.

Navien Inc. is not liable for any property damage, personal injury or death resulting from improper conversions.

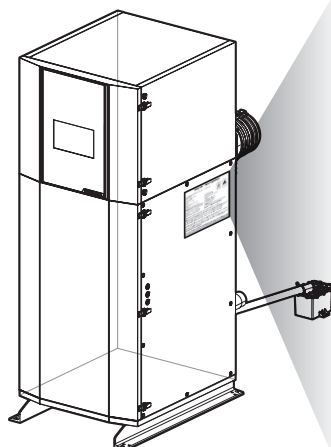

Rating Plate, *Plaque Signalétique

Direct Vent Boiler *Évacuation directe chaudière
Navien Inc.
20 Goodyear, Irvine, CA 92618
Tel: 1-800-519-8794

FOR EITHER DIRECT VENT INSTALLATION OR FOR INSTALLATION USING INDOOR COMBUSTION AIR,
*POUR INSTALLATION AVEC ÉVACUATION DIRECTE OU AVEC AIR INTÉRIEUR COMBURANT

Model No., *Numéro de modèle
NFB700-1000C

Max./Min. Input Rating (Heating), *Entrée GPL max. 999,000 / 66,000 Btu/h	Natural Gas Gross Output, *Capacité de chauffage 974,000 Btu/h
Category of boiler, *Catégorie de chaudière Category IV	Net AHRI Rating, *Régime de AHRI 847,000 Btu/h
Max. Inlet Gas Pressure, *Pression max. de gaz d'entrée 3.5 Inches W.C. *pouces W.C.	Min. Inlet Gas Pressure, *Pression min. de gaz d'entrée 0.5 Inches W.C. *pouces W.C.
Manifold Pressure, *Pression d'admission Electrical Rating, *Régime nominal électrique AC *c.a. 120 Volts 60Hz Use less than 12 Amp, *Utilise moins de 12A	Minimum relief valve capacity, *Capacité minimum soupape. 1000 lbs/hr CSA/ANSI Z21.13:2022 • CSA 4.9:2022

Orifices necessary for Propane conversion are provided. *Les injecteurs nécessaires à la conversion au Propane sont fournis.

Failure to use the correct gas can cause problems which can result in death, serious injury or property damage. *Le fait de ne pas utiliser le bon gaz peut causer des problèmes qui peuvent mener à la mort, causer des blessures graves ou endommager la propriété.

Consult your installation manual for more information. *Consultez votre manuel d'installation pour plus d'information.

This appliance is certified for use at altitudes up to 4,500 ft (1,370 m) in accordance to the latest CAN/CGA 2.17-High Altitude Installation procedures at normal manifold pressure. This appliance has also been tested up to 10,100 ft (3,078 m).
For installations at altitudes up to 10,100 ft (3,078 m), follow the directions provided in the High Altitude Installations sections of the Installation Manual. *Cet appareil est certifié pour une utilisation à des altitudes de 0 à 4,500 pieds (1,370 m) conformément aux toutes les procédures d'installation à haute altitude CAN/CGA 2.17 à une pression normale. Cet appareil a été testé jusqu'à 10 100 pieds (3 078 m). Pour les instructions d'installation à une altitude supérieure à 10 100 pieds (3 078 m), suivez les instructions fournies dans la section des installations à haute altitude du manuel d'installation.

This appliance must be installed in accordance with local codes or in the absence of local codes, the most recent edition of National Fuel Gas Code, ANSI Z223. 1, in Canada use CAN/CGA B149, 1 or 2 installation codes for Gas Burning Appliances.
*Cet appareil doit être installé conformément aux codes locaux, ou s'il n'y a pas de codes locaux, la plus récente version du National Fuel Gas Code des E.-U., ANSI Z223. 1, au Canada utilisez les codes d'installation CAN/CGA B149, 1 ou 2 pour les appareils à gaz.

FOR YOUR SAFETY *POUR VOTRE SÉCURITÉ
Do not store or use gasoline or other flammable vapors and liquids in the vicinity of this or any other gas appliances. *Ne rangez pas et n'utilisez pas d'essence ou d'autres liquides ou vapeurs inflammables près de cet appareil ou de tout autre appareil électroménager.

This appliance complies with the requirements of SCAQMD Rule 1146.2 for NOx emissions of 14 ng/J or 20 ppm at 3% O₂.

2. Installing the Boiler

2.1 Choosing an Installation Location

When choosing an installation location, you must ensure that the location provides adequate clearance for the boiler, adequate venting and drainage options, and sufficient access to gas, water, and electrical supplies. Carefully consider the following factors when choosing an installation location:

WARNING

- Do not install outdoors. Outdoor installation may result in property damage, severe personal injury, or death. Damage to the boiler resulting from installation outdoors is not covered by warranty.
- Do not install this boiler in a recreational vehicle, trailer, boat or other moving vehicles as it will result in a Carbon Monoxide Poisoning Hazard.

Note

- Installer must verify that at least one carbon monoxide detector is installed within the residential living space before placing the boiler into operation. Refer to the manufacturer's instructions and local codes as well as the Consumer Product Safety Commission (CPSC) and Environmental Protection Agency (EPA) recommendations for proper use of carbon monoxide alarms.
- If the boiler is installed in Massachusetts, see "11.5 Requirements for the State of Massachusetts" on page 131.

Compliance Requirements

- Local, state, provincial, and national codes, laws, regulations, and ordinances.
- National Fuel Gas Code, ANSI Z223.1-latest edition.
- Standard for Controls and Safety Appliances for Automatically Fired Boilers, ANSI/ASME CSD-1, when required.
- National Electrical Code.
- For Canada only: B149.1 Installation Code, CSA C22.1 Canadian Electrical Code Part 1, CSA-B214-12 Installation code for hydronic heating systems, and any local codes.

Access to Utilities

- Water – the installation location should be near where the domestic water supply enters the building.
- Gas – the installation location should be near where the gas supply enters the building.
- Electricity – the installation location should be near where the electrical supply enters the building.

Humidity and Contact with Water

When installing the boiler, avoid places with excessive humidity. The boiler has electric gas ignition components. Moisture can get inside the boiler and damage the ignition system. The boiler must be installed in a way to ensure that the gas ignition system components are protected from water (dripping, spraying, rain, etc.) during operation and service.

Flooring

- The floor where the boiler is to be installed must be level. If the floor is uneven, sloped, or prone to flooding, install a sturdy concrete foundation pad at least 2 in (51 mm) above the floor before installing the boiler on the pad.
- The boiler must not be installed on carpeting.

WARNING

Do not install a boiler on carpeting even if a foundation is used. Fire can result in severe personal injury, death, or substantial property damage.

Adequate Drainage

The boiler produces a significant amount of condensate during operation. The boiler should be located near a suitable drain and where damage from a possible leak will be minimal. Installing the boiler in a location without a drain will void the warranty and Navien will not be responsible for water damages that occur as a result. For more information about condensate drainage, refer to “3.2 Connecting the Condensate Drain” on page 28.

The boiler must be located in an area where leakage of the unit or connections will not result in damage to the area adjacent to the appliance or to lower floors of the structure. When such locations cannot be found, installation of an adequately drained drain pan under the boiler is highly recommended. When installing the drain pan, ensure that the installation does not restrict combustion air flow.

Adequate Venting and Ventilation

Select a location that requires minimal venting. Consider venting restrictions caused by windows, doors, air intakes, gas meters, foliage, and other buildings. For more information about venting, refer to “5. Venting for Combustion Air” on page 59.

To ensure adequate venting and ventilation, follow these guidelines:

- Maintain proper clearances from any openings in the building.
- Ensure that the vent termination is at least 12 in (305 mm) above ground, 12 in (305 mm) above the highest anticipated snow level, or as required by local codes, whichever is greater.
- Do not enclose the vent termination.
- Install the exhaust vent in an area that is free from any obstructions, where the exhaust will not accumulate.
- Do not install the boiler where moisture from the exhaust may discolor or damage walls.
- Do not install the boiler in bathrooms, bedrooms, or any other occupied rooms that are normally kept closed or not adequately ventilated.

Adequate Installation Clearances for Service and Maintenance

NOTICE

Do not install the boiler on carpeting.

Install the boiler in an area that allows for service and maintenance access to utility connections, piping, filters, and traps. Based on the installation location, ensure that the following clearances are maintained:

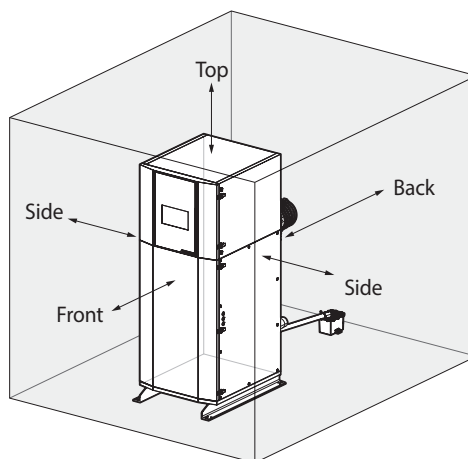

Clearance from:	Indoor Installation
Top	24 in (610 mm) minimum
Back	24 in (610 mm) minimum
Front	30 in (762 mm) minimum
Sides	24 in (610 mm) minimum

Note

If the clearances above are not maintained, servicing the boiler may not be possible without removing it from the installation space.

CAUTION

To ensure proper operation, minimum specified clearances must be maintained. All installations must provide sufficient space for vent connections, water piping connections, piping and other equipment, and for servicing the unit itself. For installation instructions appropriate to each type of venting system, refer to “5. Venting for Combustion Air” on page 59.

Combustible Material Clearance Requirements

Ensure that the following clearances are maintained when installing the boiler near combustible materials.

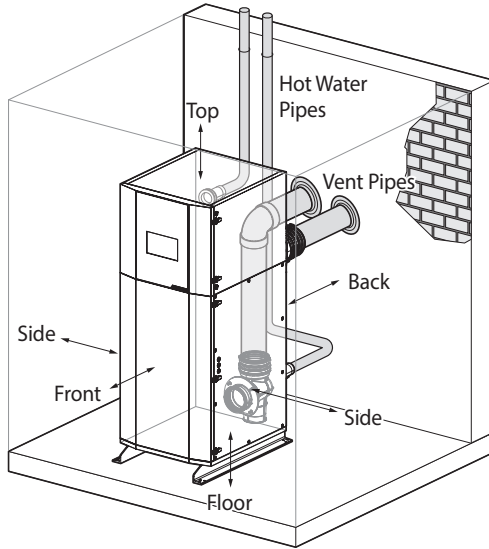

Clearance from:	Combustible Materials
Top	0" (0 mm)
Back	0" (0 mm)
Front	0" (0 mm)
Side	0" (0 mm)
Hot water pipes	1" (25.4 mm) minimum
Floor	Combustible materials allowed if not in contact with piping.
Vent Pipe	Refer to the vent pipe manufacturer's instructions.

Note The NFB700 boiler allows for 0 in (0 mm) clearance from combustible surfaces or materials, so multiple units can be installed side by side or in a cascade configuration without spacing between them. However, side-by-side installation may limit service and maintenance accessibility from the sides.

Clean, Debris and Chemical-free Combustion Air

- Do not install the boiler in areas where dust and debris may accumulate or where hair sprays, spray detergents, chlorine, or similar chemicals are used.
- Do not install the boiler in areas where gasoline or other flammables are used or stored.
- Ensure that combustible materials are stored away from the boiler and that hanging laundry or similar items do not obstruct access to the boiler or its venting.

Note The combustion air must be free of flammable vapors or corrosive chemical fumes. Common corrosive chemical fumes to avoid include fluorocarbons and other halogenated compounds such as Freon, trichloroethylene, perchloroethylene, chlorine, all of which can be found in refrigerants or solvents. When these chemicals burn, they produce acids that corrode the stainless steel heat exchanger, gaskets, and the flue and vent system.

Operating Temperature

The ambient temperature at the installation location must be above 32°F (0°C) and below 120°F (49°C).

High Altitude Installations

- This unit may be installed at elevations up to 10,100 ft (3,078 m) for use with natural gas and propane. Refer to "6. Setting the DIP Switches" on page 74 for the appropriate altitude setting.
- Natural gas units require the use of the Natural Gas High Altitude Conversion Kit if installed at an elevation of 5,400 ft (1,646 m) or higher.

! WARNING

- ALWAYS read and follow the Natural Gas High Altitude Conversion Guide when installing the gas orifice included with the kit in order to prevent death, serious injury or property damage.
- The front cover will need to be removed from the boiler to access the High Altitude Conversion Kit.

2.2 Securing the Boiler to the Floor

1. Use a level to ensure the installation surface is flat, then position the boiler in a location that meets the required installation clearances.

WARNING

- When lifting or handling the boiler, be cautious to prevent it from being dropped, which could cause injury or damage to the boiler. It is recommended to use lifting equipment when lifting the boiler. The maximum load of the unit should be calculated based on its weight, including water.
- The boiler must be installed on a flat surface. If not, the following issues may occur:
 - The boiler may tip over, resulting in damage or injury to nearby individuals.
 - Condensate may not drain properly, leading to reduced performance or leaks that could cause the boiler to malfunction.

2. Secure the boiler to the floor by using the 4 provided anchor bolts through the holes in the base supports.

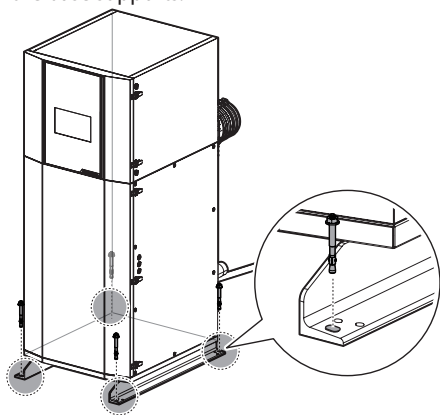

NOTICE

When installing the fixing screws into the floor, make sure to prevent foreign objects from entering the air intake or exhaust connections.

2.3 Installing the Flue Gas Vent Kit and Vent Support Kit

To install the flue gas vent kit and vent support kit on the boiler:

Note Before installation, ensure all components are included in the kit packages (Vent Adapter Kit and Vent Supporter Kit).

Flue Gas Vent Kit Vent Support Kit

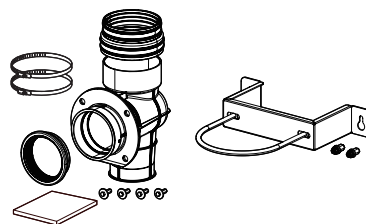

1. Connect the vent adapter to the drain pan outlet, and then place the rubber pad under the adapter.

Note

- Ensure that vent packing and 2 clamps are assembled onto the vent adapter before installing it.
- Ensure the vent exhaust tee is properly supported. Uneven floors may require additional support or shims.

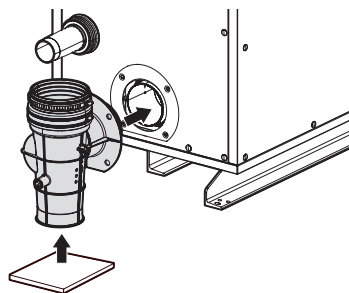

2. Tighten the 4 screws (torque: 50 kgf-cm, 3.5 ft-lbs) on the vent adapter to securely attach the adapter to the drain pan outlet.

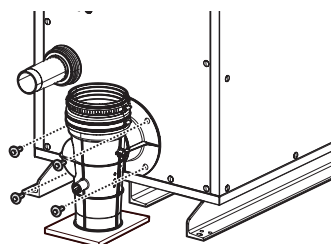

3. Place the vent support on the rear side of the boiler, then secure it with 2 screws.

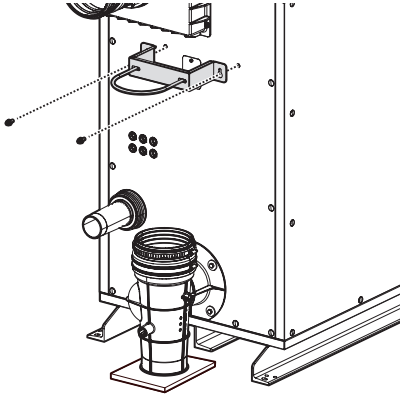

6. Fasten the clamp to secure the vent pipe to the vent adapter.

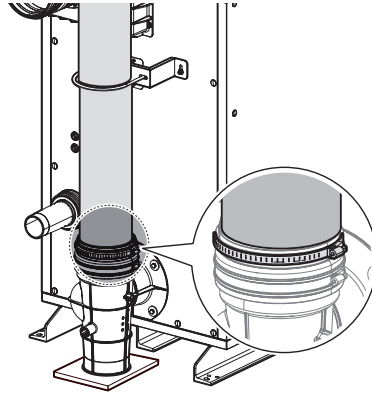

4. Insert the vent pipe through the vent support ring, then adjust the spacing of the vent support ring to prevent the vent from tilting.

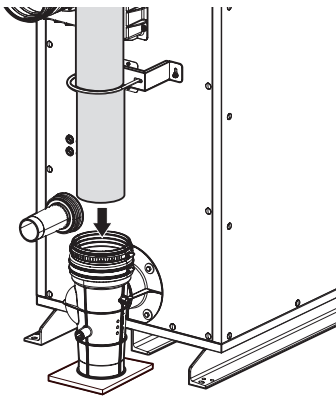

5. Verify that 4.7" (120 mm) of the pipe has been completely inserted into the vent adapter and that the mark is no longer visible.

3. Installing the System Piping

CAUTION

The cold water fill pressure for the NFB700 boiler should be at least 12 psi. The operating pressure must not exceed the pressure set on the pressure relief valve.

Prior to connecting piping to the boiler, flush the entire system to ensure it is free of sediment, flux, solder, scale, debris or other impurities that may be harmful to the system and boiler. During the assembly of the heating system, it is important to keep the inside of the piping free of any debris including construction dust, copper burrs, sand and dirt.

For retrofits, all system piping including radiators, must be cleaned of all build-up including sludge and scale. All systems, old and new, must be cleaned to remove flux, grease and carbon residue. Navien recommends cleaning the boiler system with cleaning products specially formulated for boiler systems. For retrofit applications with heavy limescale and sludge deposits, a heavier duty cleaner may be required. For information on performing the cleaning, follow the instructions included with the boiler system cleaner products.

NOTICE

- Failure to rid the heating system of the contaminants listed above will void your warranty and may result in premature heat exchanger failure and property damage.
- To avoid damaging the connectors on the boiler, use two wrenches when tightening piping to the boiler. Use one wrench to prevent the connector at the boiler from turning, and use the other wrench to tighten the connection. Damaged connectors may result in system leaks.
- Properly support the piping with hangers. Do not allow the piping to be supported by the boiler or its accessories.

3.1 Installing a Space Heating System

The fire-tube type heat exchanger of the Navien NFB700 boiler is designed to attain the highest level of heat transfer in a compact design. To accomplish this, the heated gas flows through a series of small-diameter tubes, maximizing the heat transfer area. To maintain the efficient and reliable operation of the heat exchanger, and to avoid heat exchanger failure, it is critical to ensure the rules and guidelines in this section are followed.

WARNING

Failure to follow the instructions provided in this section will void the warranty and may result in property damage, fire, serious injury or death.

3.1.1 Guidelines for a Space Heating Installation

Read and follow the guidelines listed below to ensure safe and proper installation of a boiler heating system.

Freeze Protection for a Space Heating System

- Freeze protection products may be used for the space heating system. Freeze protection for new or existing systems requires specially formulated glycol, which contains inhibitors to prevent the glycol from attacking the metallic system components.
- Before using freeze protection products, ensure that system fluid contains proper glycol concentration and the inhibitor level is appropriate. Navien recommends against exceeding a 50% concentration of glycol.
- When using the freeze protection products, the system must be tested at least once a year, and as recommended by the manufacturer of the glycol solution.
- When using the freeze protection products, allowance should be made for expansion of the glycol solution.
- Freeze damage is not covered by the warranty.
- The use of glycol results in a greater head loss due to its higher viscosity compared to water. Refer to "Temperature Rise Conditions" on page 27 for additional specifications for up to 50% glycol.

NOTICE

- For systems requiring freeze protection, use only inhibited propylene glycol, specially formulated for hydronic heating systems. Using other types of antifreeze, such as those designed for vehicles, may damage the system and void the warranty.
- NEVER use vehicle antifreeze for the unit. Doing so may damage the system, cause corrosion or scaling, and void the warranty.

⚠ WARNING

- Immediately repair any leaks in the system piping to avoid adding make-up water. Make-up water adds air and minerals to the system that may lead to heat exchanger failure.
- Do not solder piping directly onto the water connections, as the heat may cause damage to internal components. Use threaded water connections only.
- Failure to follow these instructions may result in poor performance, unnecessary wear of system components and premature failure of the heat exchanger.

System Pressure

- The Navien NFB700 boiler is intended solely for use in pressurized closed loop heating systems operating with 12-160 psi water pressure at the boiler outlet. To obtain the minimum system design pressure, follow the piping diagrams illustrated in this section.
- The Navien NFB700 boiler's space heating system is not approved for operation in an "open system", thus it cannot be used for direct potable water heating or to process heating of any kind.

Elimination of Air

This boiler may only be installed in a pressurized closed-loop heating system, free of air and other impurities. To avoid the presence of air, ensure all of the air is removed from the system during commissioning via strategically placed and adequately sized air removal appliances, located throughout the heating system. Ensure an appropriate water level and that the vent cap is not blocked which may cause air in the system.

- Note** See the examples of system application at the end of this section detailing the installation location of the air removal appliances, in case an additional air removal appliances is required for a specific application.

3.1.2 Essential Elements in a Space Heating System

Boiler Piping Options

The following illustrations show various boiler piping options. Before installing water pipes on the boiler, thoroughly inspect the area to ensure there is no interference between the water pipes and gas supply line.

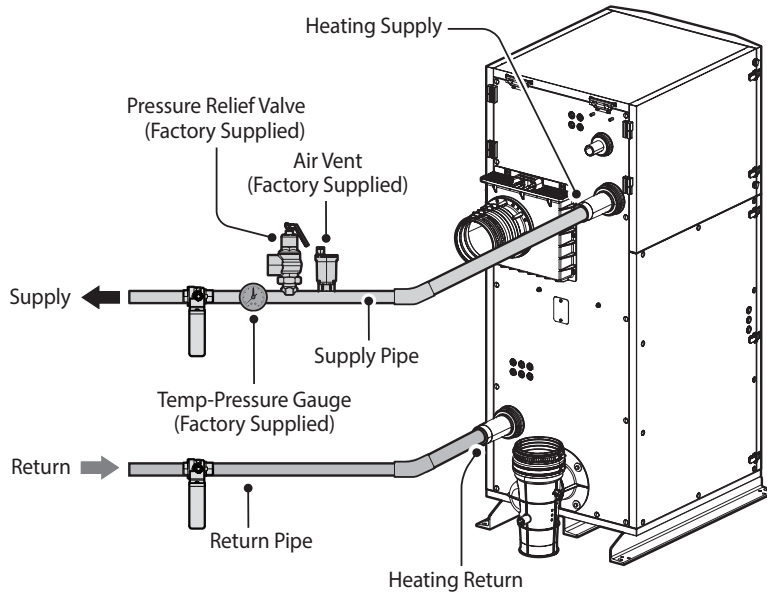

Air Vent

The following figure illustrates an example of a typical air vent installation. A separate air separator is required for the make-up water line. Refer to "3.3.1 Make-up Water Connection" on page 33 for air separator installation.

Note

When using the universal adapter (#GXXX002963), install the pressure relief valve prior to the air vent to prevent component or piping interference. The pressure relief valve may interfere with the air vent if not installed first.

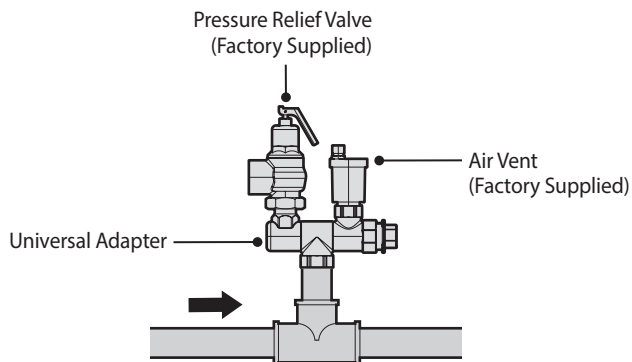

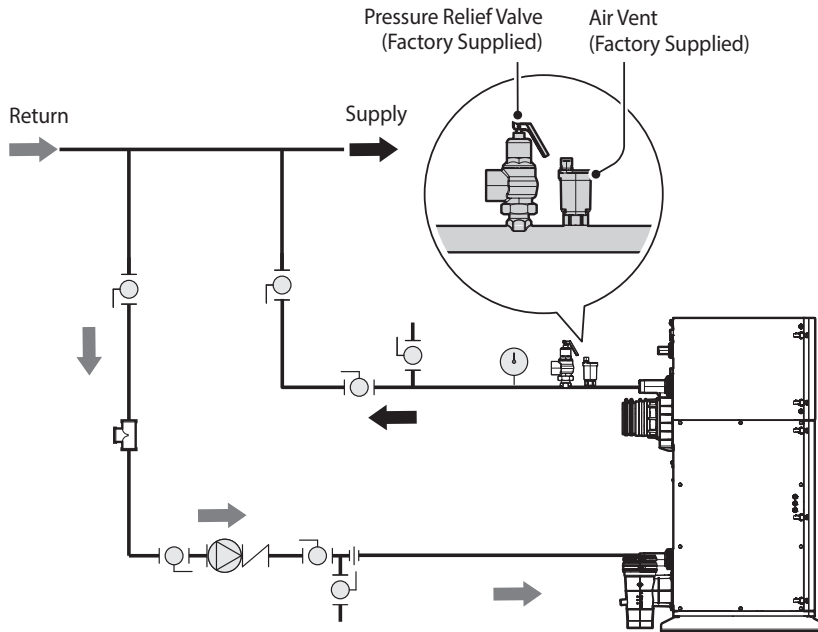

Pressure Relief Valve and Air Vent

To complete the space heating system installation, you must install a pressure relief valve and air vent on the boiler supply pipe. An ASME approved HV pressure relief valve and air vent for space heating system are supplied with the boiler. You can use an universal adapter as an optional accessory to install relief valve and air vent.

⚠ WARNING

- Installing the pressure relief valve improperly may result in property damage, personal injury, or death. Follow all instructions and guidelines when installing the pressure relief valve. The valve should be installed only by a licensed professional.
- The pressure relief valve must be installed at the boiler and in the vertical position, as shown in this section, with the drain pipe outlet exiting the side of the pressure relief valve horizontally and elbowing down.
- Install the pressure relief valve as close to the boiler as possible. No other valve should be installed between the pressure relief valve and boiler.

When installing the pressure relief valve, follow these guidelines:

- Ensure that the valve's discharge capacity is equal to or greater than the maximum pressure rating of the boiler's space heating system.
- Ensure that the maximum BTU/H rating on the pressure relief valve is equal to or greater than the maximum input BTU/H rating of the boiler.
- Direct the discharge piping of the pressure relief valve so that hot water does not splash on the operator or equipment.
- Attach the discharge line to the pressure relief valve and run the end of the line to within 6-12 in (152-305 mm) of the floor drain, making the discharge clearly visible.
- Do not direct the discharge line to a location where freezing could occur.
- Ensure that the discharge line is not plugged or obstructed.
- After filling and pressurizing the system, test the relief valve operation by lifting the lever. If the valve fails to operate correctly, immediately replace the relief valve.
- Ensure that the discharge line provides complete and unobstructed drainage. Do not install a reducing coupling or other restrictions on the discharge line.

If the relief valve discharges periodically, this may be caused by thermal expansion when the expansion tank is full or undersized. Do not plug the relief valve.

The illustration below shows an example of a pressure relief valve, an air vent and a pressure gauge on the pipe. Install the included pressure relief valve and air vent on the boiler supply pipe. Additionally, install the temperature-pressure gauge included in the accessory box into the pipe.

Note A pressure relief valve, an air vent and a temperature and pressure gauge are included in the accessory box.

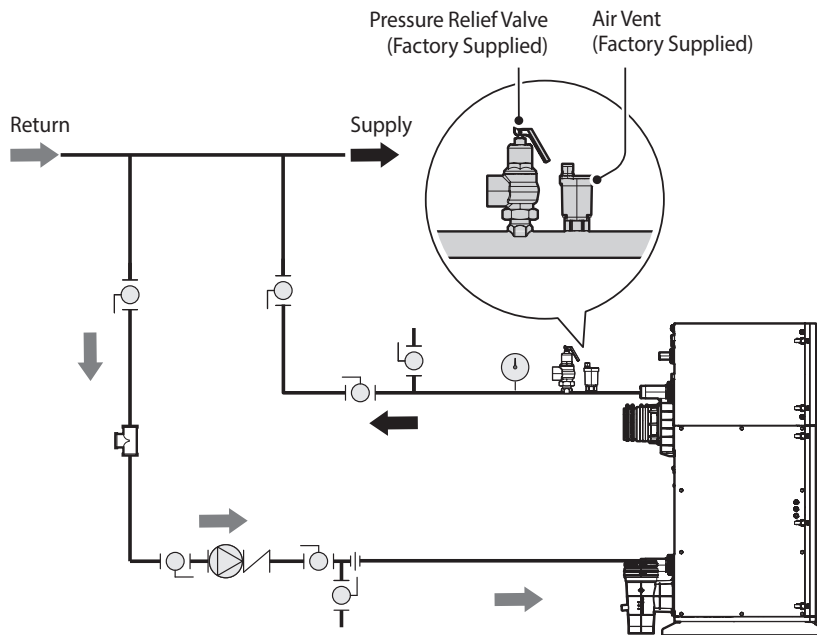

⚠ WARNING

- To prevent scalding, burns and water damage, always route the discharge line to a safe location.
- To prevent serious injury or death, the pressure relief valve should be checked at least once every three years by manually operating the relief valve.
- Before manually operating the valve, check the discharge line and discharge location to ensure you or others will not come in contact with hot water. Hot water can cause burns and may result in serious injury or property damage.
- Do not close the air vent's cap. If it is closed while the boiler is being used, air will not be purged properly and it will damage the boiler. Such damage is not covered by the warranty, and may result in property damage, severe personal injury, or death.

Note All field supplied pressure relief valves must be ASME certified.

Backflow Preventer

Install a backflow preventer valve in the make-up water supply to the unit as required by local codes. Installation of a backflow preventer or an actual disconnection from city water supply may be required.

Expansion Tank

An expansion tank must be installed in the space heating piping to prevent excessive pressure from building in the system. See the examples of system application at the end of this section for the installation location. Refer to the expansion tank manufacturer's instructions for additional details.

Follow the guidelines below when installing an expansion tank.

- Connect an air separator to the expansion tank only if the air separator is located on the suction side of the system pump.
- The make-up water connection can be attached at the same location as the expansion tank's connection to the system.

- When replacing an expansion tank, consult the expansion tank manufacturer's literature for proper sizing.
- For diaphragm expansion tanks, always install an automatic air vent on the top side of the air separator to remove residual air from the system.

Isolation Valves and Unions

- Full port ball valves are required for the boiler system. Failure to use full port ball valves could result in a restricted flow rate through the boiler.
- Check valves are recommended for installation. Failure to install check valves could result in a reverse flow condition during pump(s) off cycle.
- Unions are recommended for unit serviceability.

Magnetic Filtration

The magnetic filter is an optional accessory that is connected to the space heating return near the boiler piping to protect the boiler from iron oxide (magnetite). Magnetic filters must be sized properly to ensure protection of the boiler.

Low Water Cut Off (LWCO) Device

The Navien NFB700 boiler is equipped with a factory-installed, electrode type low water cutoff (LWCO) device. This sensor prevents the boiler from operating when the water level is insufficient, protecting the heat exchanger from overheating.

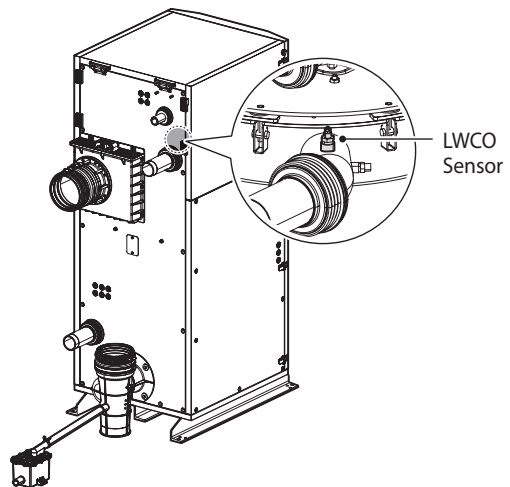

When the built-in LWCO sensor detects a low water level in the boiler, the E777 (Low Water Cut Off Error) error code occurs.

Note If the E777 error code occurs, also check the following:

- Check if the boiler system is fully filled with water and there is no residual air in the system.
- Verify the LWCO probe wiring connections

Follow the instructions below to clear the E777 error code and verify normal LWCO operation.

Resetting the E777 Error Code

1. Open the lower-front cover of the boiler. Refer to "3.6.1 Accessing the Terminal Strips" on page 39.
2. Toggle the reset switch to the unlocked position (○) and wait for at least 5 seconds.

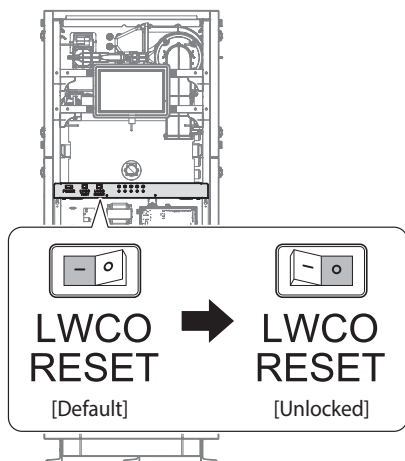

3. After 5 seconds, toggle the reset switch to the default position (–), then check if the E777 error code is cleared.

Verifying Normal LWCO Operation

1. Open the lower-front cover of the boiler. Refer to "3.6.1 Accessing the Terminal Strips" on page 39.
2. Toggle the test switch to the unlocked position (○) and wait for at least 5 seconds.

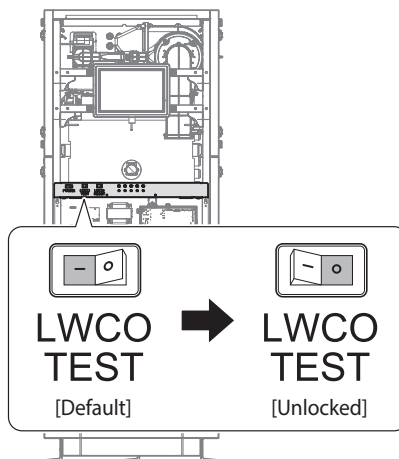

3. After 5 seconds, toggle the test switch to the default position (–), then check if the E777 error code occurs.
4. Toggle the reset switch to the unlocked position (○) and wait for at least 5 seconds. Then, toggle the switch to the default position (–).

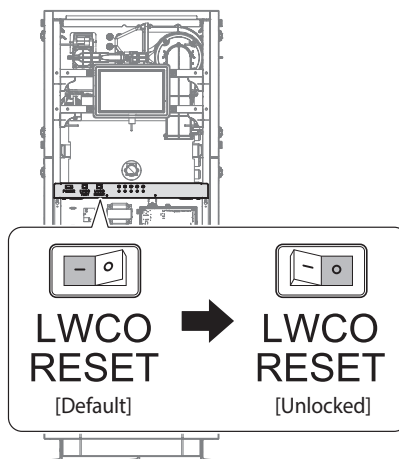

5. Check if the E777 error code is cleared.

3.1.3 Space Heating System Piping

When connecting the space heating system, follow these guidelines:

- Carefully tighten all connections to avoid damage to fittings.
- After installing the boiler, check the space heating system's operation and inspect for leaks.

PQ Curve

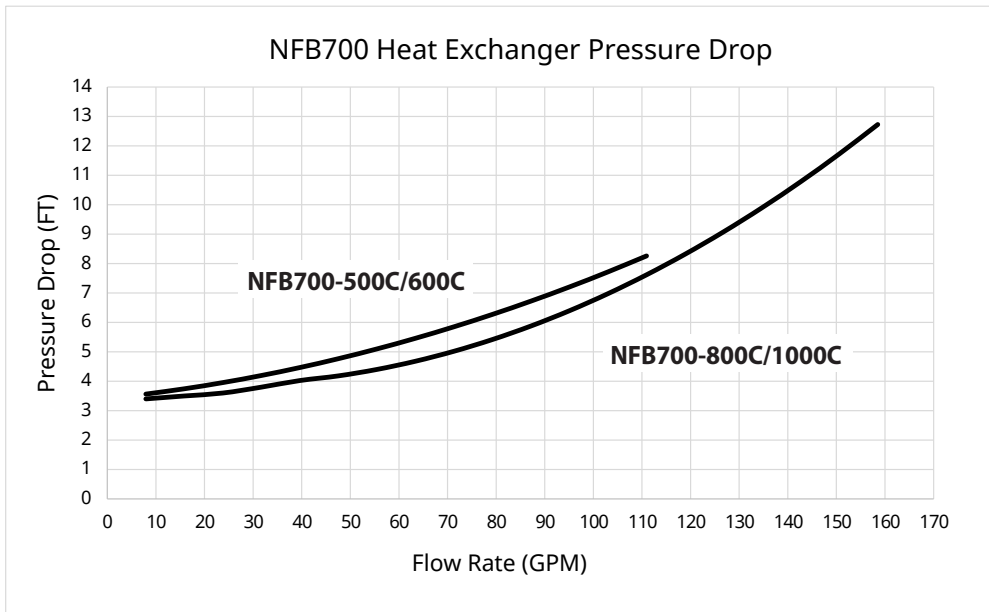

NFB700-500C/600C

Q(GPM)	10	20	30	40	50	60	70	80	90	100	110
Pressure Drop (FT)	3.5	3.8	4.2	4.5	4.9	5.3	5.8	6.3	6.9	7.5	8.1

NFB700-800C/1000C

Q(GPM)	10	20	30	40	50	60	70	80	90	100	110	120	130	140	150
Pressure Drop (FT)	3.5	3.6	3.7	3.9	4.2	4.6	5.0	5.5	6.1	6.7	7.5	8.3	9.30	10.4	11.6

Maximum and Minimum Flow Rates through the Boiler

Model	Minimum Pipe Diameter	Maximum Flow (GPM)	Minimum Flow (GPM)
NFB700-500C	2"	110	18
NFB700-600C		110	22
NFB700-800C	2½"	160	29
NFB700-1000C		160	36

Temperature Rise Conditions

Model	20°F ΔT @100% water		30°F ΔT @100% water		40°F ΔT @100% water		54°F ΔT @100% water	
	Flow Rate (GPM)	Head (FT)	Flow Rate (GPM)	Head (FT)	Flow Rate (GPM)	Head (FT)	Flow Rate (GPM)	Head (FT)
NFB700-500C	49	4.9	32	4.2	24	4.0	18	3.8
NFB700-600C	58	5.3	39	4.5	29	4.1	22	3.9
NFB700-800C	78	5.4	52	4.3	39	3.9	29	3.7
NFB700-1000C	97	6.5	65	4.8	49	4.2	36	3.8

Model	20°F ΔT @30% glycol		30°F ΔT @30% glycol		40°F ΔT @30% glycol		54°F ΔT @30% glycol	
	Flow Rate (GPM)	Head (FT)	Flow Rate (GPM)	Head (FT)	Flow Rate (GPM)	Head (FT)	Flow Rate (GPM)	Head (FT)
NFB700-500C	52	5.0	35	4.3	26	4.0	19	3.8
NFB700-600C	63	5.5	42	4.6	31	4.2	23	3.9
NFB700-800C	84	5.7	56	4.4	42	4.0	31	3.7
NFB700-1000C	105	7.1	70	5.0	52	4.3	39	3.9

Model	20°F ΔT @50% glycol		30°F ΔT @50% glycol		40°F ΔT @50% glycol		54°F ΔT @50% glycol	
	Flow Rate (GPM)	Head (FT)	Flow Rate (GPM)	Head (FT)	Flow Rate (GPM)	Head (FT)	Flow Rate (GPM)	Head (FT)
NFB700-500C	58	5.3	39	3.3	29	4.1	21	3.9
NFB700-600C	70	5.8	46	4.8	35	4.3	26	4.0
NFB700-800C	93	6.2	62	4.6	46	4.1	34	3.8
NFB700-1000C	116	8.0	77	5.3	58	4.5	43	4.0

Minimum Flow Rates through the Boiler for Use with Glycol

Model	Minimum Flow (GPM)	
	For Use With 30% glycol	For Use With 50% glycol
NFB700-500C	19	21
NFB700-600C	23	26
NFB700-800C	31	34
NFB700-1000C	39	43

3.2 Connecting the Condensate Drain

The Navien NFB700 boiler creates condensation when it operates. This condensation has an acidic pH of 3-5. Follow all local codes and regulations when disposing of condensate from the boiler.

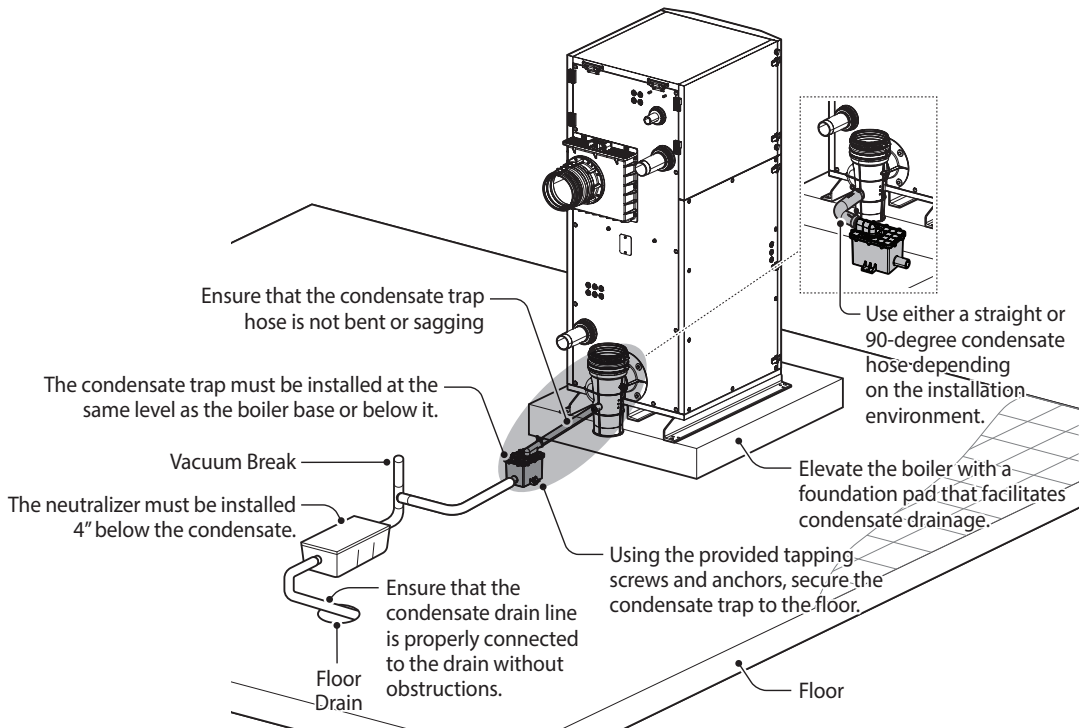

⚠ WARNING

- Fill the condensate trap with water after installing the condensate drain pipe.
- Do not cap or plug the integrated condensate line. If prevented from draining, condensate can damage the boiler.
- The condensate line must have a negative slope to drain properly.
- NEVER drink or allow animals to drink condensate. The pH of the condensate could cause serious injury.

To install the condensate trap on the boiler:

Note Tapping screws, anchors, and the condensate hose are included with the condensate trap.

1. Connect the condensate hose to both the condensate trap cover and the drain outlet on the boiler, then secure it with clamps.

Note Use either a straight or 90-degree condensate hose depending on the installation environment.

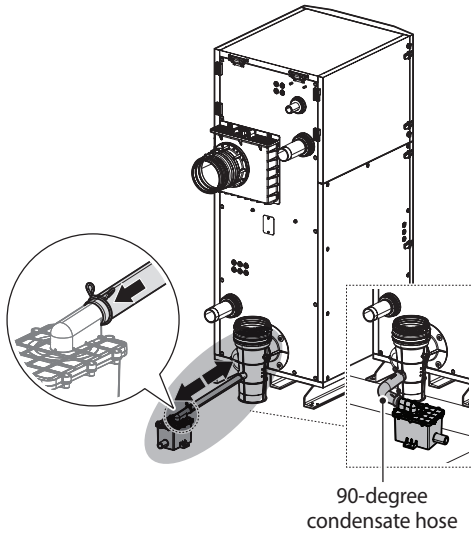

2. Ensure the condensate flows downward and use 2 tapping screws and anchors to secure the condensate trap to the floor.

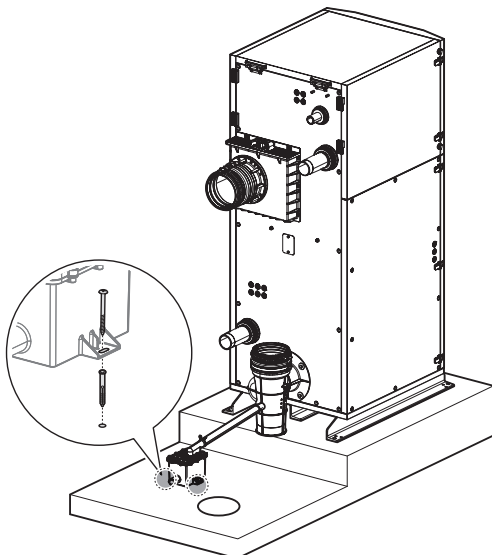

⚠ CAUTION

- To ensure proper drainage of condensate, the installation height of the condensate trap must be the same as or lower than the boiler.
- The condensate hose must not be kinked or sagging.
- If the condensate trap is improperly installed, resulting in poor drainage, it may cause a condensate blockage and damage the boiler.
- Ensure that the discharge hose of the condensate trap is installed to allow proper drainage into the external drain.

Before connecting the condensate drain, choose one of the following disposal options:

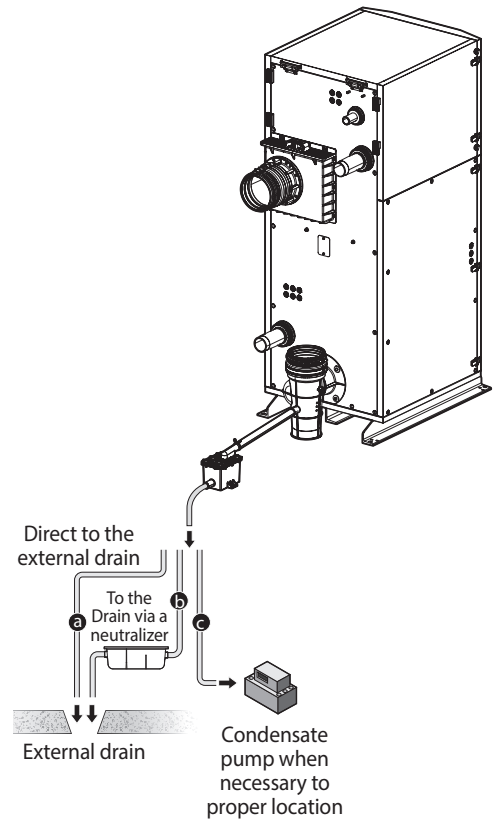

- a. From the boiler directly into an external drain
- b. From the boiler, through a neutralizing agent, and then into an external drain

Note

- If you choose this option, the neutralizing agent must be replaced periodically. Depletion of the neutralizing agent will vary, based on the usage rate of the boiler. During the first year of operation, the neutralizer should be checked every few months for depletion and replaced as needed.
- The neutralizer must be installed 4" below the condensate. Follow local codes and instructions included with the neutralizer to connect the condensate trap to the neutralizer.

- c. From the boiler into a condensate pump, and then into an external drain.

Note

A pump can be used when there is a long distance between the boiler and drain or when the bottom of the boiler is lower than the top of the drain.

To connect the condensate drain:

1. Connect a drain line to the 1 in fitting to the condensate trap.

Use only corrosion-resistant material for the drain line, such as PVC or CPVC. Do not reduce the size of this fitting or the drain line to less than 1 in.

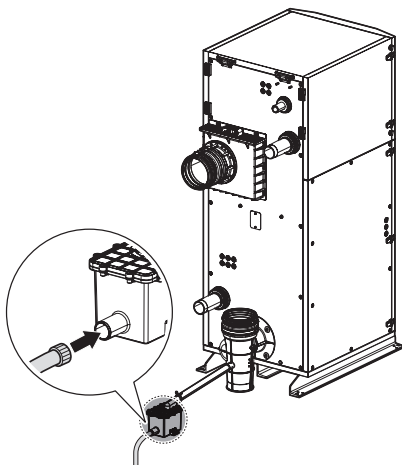

2. Place the free end of the drain line into an appropriate drain.
 - If you are using a condensate pump, ensure that the pump allows for up to 8.5 GPH of drainage for each boiler in the system.
 - If you are not using a condensate pump, ensure that the drain line is pitched downward at a minimum slope of ¼ in per foot.

NOTICE

To prevent property damage, do not allow condensate line to freeze or become obstructed or condensate can flow from the drain.

Maintenance

Periodically monitor the level of media in the neutralizer and test the pH level at the outlet. We recommend an annual pH test using recognized test strips or an electronic pH meter to obtain precise measurements. Replace the neutralizing media when the pH drops below the minimum level required by the local water authority or after one year. If the pH level is not specified, replace the neutralizing media when the pH is below 6.5. For replacement media, contact your local Navien distributor.

As part of this annual maintenance procedure, make sure to clean out the condensate trap which may contain excess debris. Drain the condensate within the trap, then replace with fresh water using the provided access port.

3.2.1 Commercial Condensate Neutralizer Kit

⚠ WARNING

To prevent serious injury or death:

- DO NOT allow exhaust flue gases to vent through the neutralizer. Inhalation of flue gases can result in carbon monoxide poisoning.
- ALWAYS install the neutralizer lower than the condensate drain.
- ALWAYS install an overflow bypass connection between the appliance and the neutralizer to prevent the backflow of condensate into the appliance.

If option 'b' is selected for condensate disposal, the Navien condensate neutralizer kit is recommended. The condensate from the appliance flows through the neutralizing media and increases the pH of the condensate. An increased pH prevents corrosion of the installation's drainage system and the public sewer system.

Installation

- The inlet has a center connection port and the outlet has an offset connection.
- Install the neutralizer on a level floor referring to "3.2 Connecting the Condensate Drain" on page 28, and then position the neutralizer outlet toward the external drain.
- Ensure that the condensate runs freely to the drain.

- Ensure all connections are made to prevent the backflow of condensate. Use corrosion resistant piping and secure all piping to prevent movement.

Note

Do not install condensate piping in areas where the temperature drops below freezing point. Protect piping in high pedestrian areas from damage and vibration.

- For increased safety when the condensate drain blocks, install a Y-fitting. Connect the Y-fitting as shown in the installation diagram and ensure that the condensate runs freely to the drain.
- Ensure that the discharge connection is accessible. Access to the discharge connection is required for maintenance and pH testing.
- If there is insufficient gradient for drainage, install a condensate pump designed for boiler and water heater condensate removal.

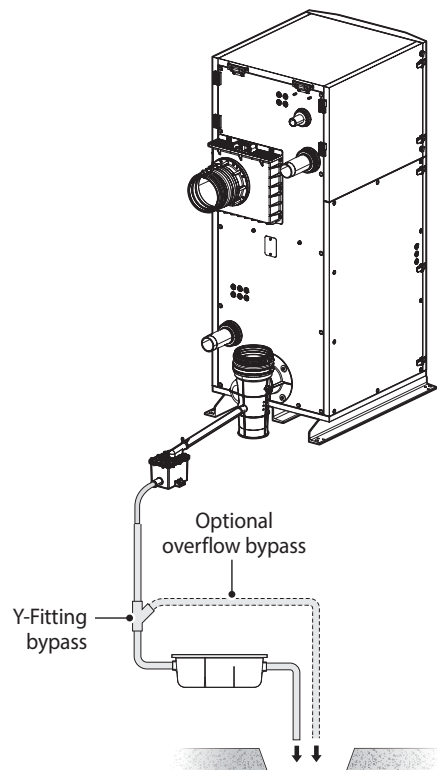

Maintenance

Periodically monitor the level of media in the neutralizer and test the pH level at the outlet. We recommend an annual pH test using recognized test strips or an electronic pH meter to obtain precise measurements. Replace the neutralizing media when the pH drops below the minimum level required by the local water authority. If the pH level is not specified, replace the neutralizing media when the pH is below 6.5. For replacement media, contact your local Navien distributor.

3.3 Filling the System

Before filling the boiler, completely unscrew and remove the air vent cap to enable the system to fill properly.

Note If the air vent cap is only partially loosened, the air vent may not allow for the boiler to fully purge. The cap must be completely unscrewed and removed to complete the procedure.

When the system is full, re-install the air vent cap and ensure that the vent screws on the system and boiler pumps are properly tightened before testing or operating the system.

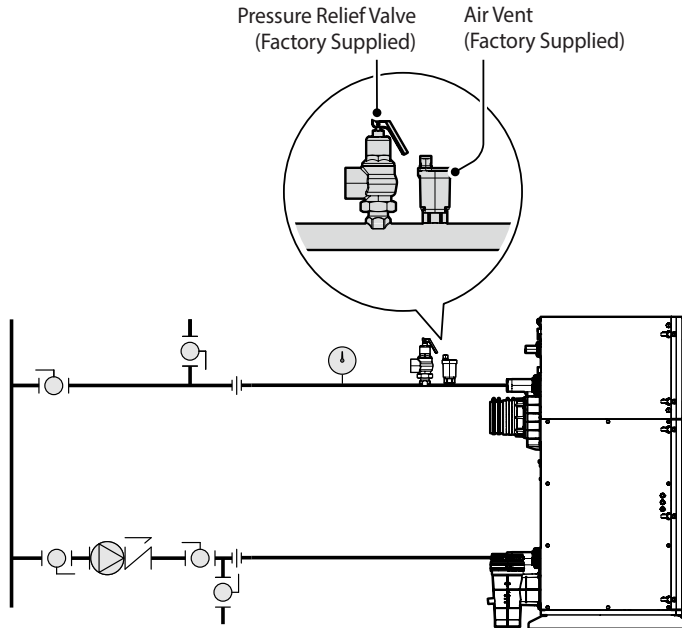

3.3.1 Make-up Water Connection

An external make-up water connection is recommended in order to keep the system completely filled.

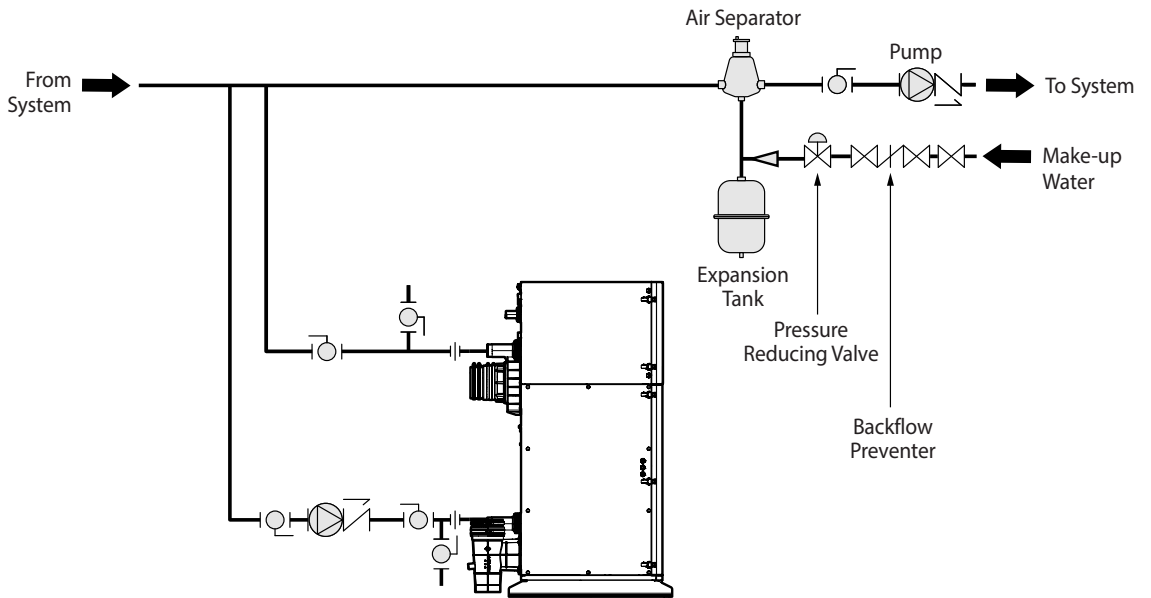

3.4 Testing the Water System

WARNING

To prevent death, serious injury or property damage:

Ensure that the boiler is full of water before firing the burner. Operating the unit without completely filling it could cause abnormal operation of the boiler and potential product damage. Such damage is not covered by the warranty.

Perform a fill test after installing the boiler's water system to make sure that the system has been installed properly. Follow the instructions below to perform a fill test on the water system.

1. Fill the system only after ensuring that the water chemistry meets the requirements.

Contaminant	Maximum Allowable Level
Total Hardness	Up to 200 mg/l (12 grains/gallon)
Aluminum	0.05 to 0.2 mg/l
Chloride	Up to 250 mg/l
Copper	Up to 1.0 mg/l
Iron	Up to 0.3 mg/l
Manganese	Up to 0.05 mg/l
pH	6.5 to 8.5
Sulfate	Up to 205 mg/l
Total Dissolved Solids (TDS)	Up to 500 mg/l
Zinc	Up to 5 mg/l
Chlorine	Up to 4 mg/l

Note

Proper maintenance of the boiler is required when water quality does not meet standards. Damage caused by poor water quality is not covered under warranty. The table above shows the maximum contaminant levels allowed. If you suspect that your water is contaminated in any way, discontinue the use of the boiler and contact an authorized technician or licensed professional.

2. Loosen the manual and automatic air vents and close the boiler drain valve.
3. Fill the boiler to the correct system pressure. The correct pressure will vary with each application. The operating pressure must never exceed the relief valve pressure setting.
4. At initial fill and during boiler start-up and testing, check the system thoroughly for leaks. Repair any leaks before proceeding further.

NOTICE

Eliminate all system leaks. The continual introduction of fresh makeup water will reduce boiler life. Minerals can build up in the heat exchanger, reducing heat transfer, overheating the heat exchanger and causing heat exchanger failure.

The system may have residual substances that could affect water chemistry. After the system has been filled and leak tested, verify that water pH and chlorine concentrations are within the acceptable range by performing sample testing.

WARNING

Before operating the boiler for the first time, ensure that the boiler system is filled with water. Purge the air inside the system to avoid dangerous operation and possible damage to the boiler.

3.5 Considerations for System Applications

Read and follow the guidelines listed below when installing system piping for the Navien NFB700 boiler:

- System application drawings are intended to explain the system piping concept only.
- Provide a system expansion tank following the guidelines on page 24.
- Installations must comply with all local codes. In Massachusetts, a vacuum relief valve must be installed in the cold water line per 248 CMR.

Air Removal

The boiler and system piping layout must be configured to promote the removal of air from the system. Air vents and bleeders must be strategically placed throughout the system to aid in purging the air from the system during commissioning of the boiler. The system must also employ the use of an air removal appliance, such as an air separator or an air eliminator designed to remove the air from the water as it flows through the system.

Follow the installation instructions included with the air removal appliance when placing it in the system. Always locate air removal appliances in areas of the system that have a higher positive pressure, e.g., in close proximity to the water fill and expansion tank.

Expansion Tank

The expansion tank must be sized in accordance with the water volume of the system as well as the firing rate of the appliance. The expansion tank must be located based on tank manufacturer specifications and industry accepted practices for proper installation.

Ensure the expansion tank cannot become isolated from the boiler anytime the system is operating. Failure to follow these instructions may lead to discharge from the pressure relief valve, which may result in property damage or injury.

Air Handler Interface

The Navien NFB700 boiler can control the operation of an air handler when a thermostat is used in combination with the air handling unit. The Air Handler Interface is designed to stop air handler operation when the boiler's space heating function is not operating due to DHW supply demands, boiler errors, or low water conditions.

The air handler contacts (A/H) turn off when the following conditions arise:

- The PCB DIP SW2 #7 is set to ON.
- Thermostat is turned off.
- The boiler is supplying DHW, or it is in stand-by mode for DHW demand.
- Level 2 or higher errors occur.
- The boiler is turned off.

CAUTION

- **Do not remove the front cover unless the power to the boiler is turned off or disconnected.** Failure to do so may result in electric shock.
- Configure only the DIP switches that require adjustment according to the instructions in this manual. Do not adjust any other DIP switches.

Configuring a Zone System

The NFB700 boiler can control up to 4 pump zones using the built-in dry contacts. After installing the system, the boiler operation must be configured accordingly using the front panel.

Thermostat Configuration for the Air Handler Interface

Set the PCB DIP SW2 #7 to down position (OFF) to use a thermostat with the Air Handler.

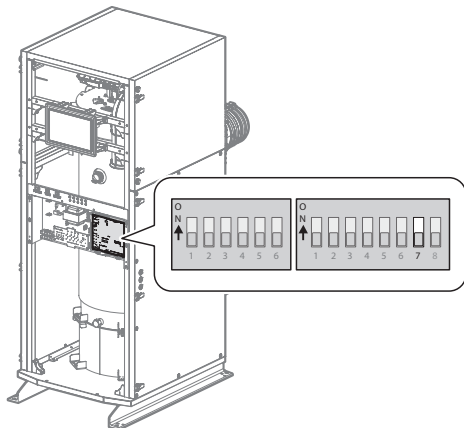

Refer to the “3.1.1 Guidelines for a Space Heating Installation” on page 47 for wiring connections.

⚠ WARNING

- Do not turn the power on until electrical wiring is finished. Disconnect power before servicing. Death or serious injury from electrical shock may result if power is supplied to the boiler during electrical wiring or servicing.
- The boiler, when used in conjunction with an air conditioning system, must be installed so that the chilled medium is piped in parallel with the heating boiler. Appropriate valves must be used to prevent the chilled medium from entering the boiler.
- If the boiler is connected to heating coils located in air handling units where they can be exposed to refrigerated air, use flow control valves or other automatic means to prevent gravity circulation of the boiler water during the cooling cycle.

DHW System

Use an indirect tank when configuring a DHW system that consists of basic boiler applications or cascade applications.

3.5.1 Examples of System Applications

Refer to the following examples to properly implement a system for space heating, DHW supply, or both. These examples are provided to suggest basic guidelines when you install the boiler system. However, the actual installation may vary depending on the circumstances, local building codes, or state regulations. Check the local building codes and state regulations thoroughly before installation, and comply with them fully.

⚠ WARNING

Ensure the power is turned off while making wiring connections. Boiler components or the boiler may fail and result in serious injury or death if power is supplied during wire connection. Product failures caused by incorrect installation are not covered by warranty.

3.5.2 System Application - Zone System with Pumps (Primary/Secondary Piping)

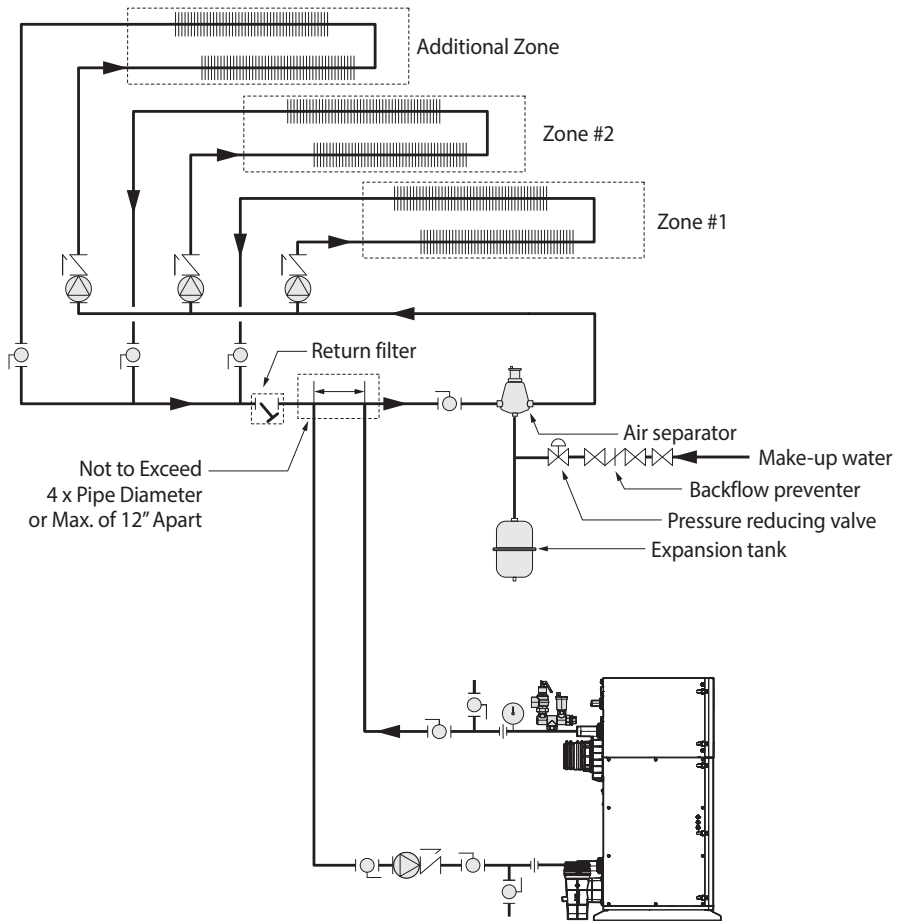

Note

- System application drawings are intended to explain the system piping concept only.
- Install a filter in the system return to remove foreign objects from the system. Foreign objects inside the system may result in abnormal system operation.
- Refer to “3.5.2 System Application - Zone System with Pumps (Primary/Secondary Piping)” on page 37 for make-up water connections and refer to the requirements of your local codes to ensure compliance.
- Use a pump with an integral check valve or install a check valve at the pump outlet.
- Refer to “3.6.5 Wiring Diagram - Generic Zone System with Circulators” on page 45 for wiring connections.

3.5.3 System Application - DHW System with Indirect Tank (Primary/Secondary Piping)

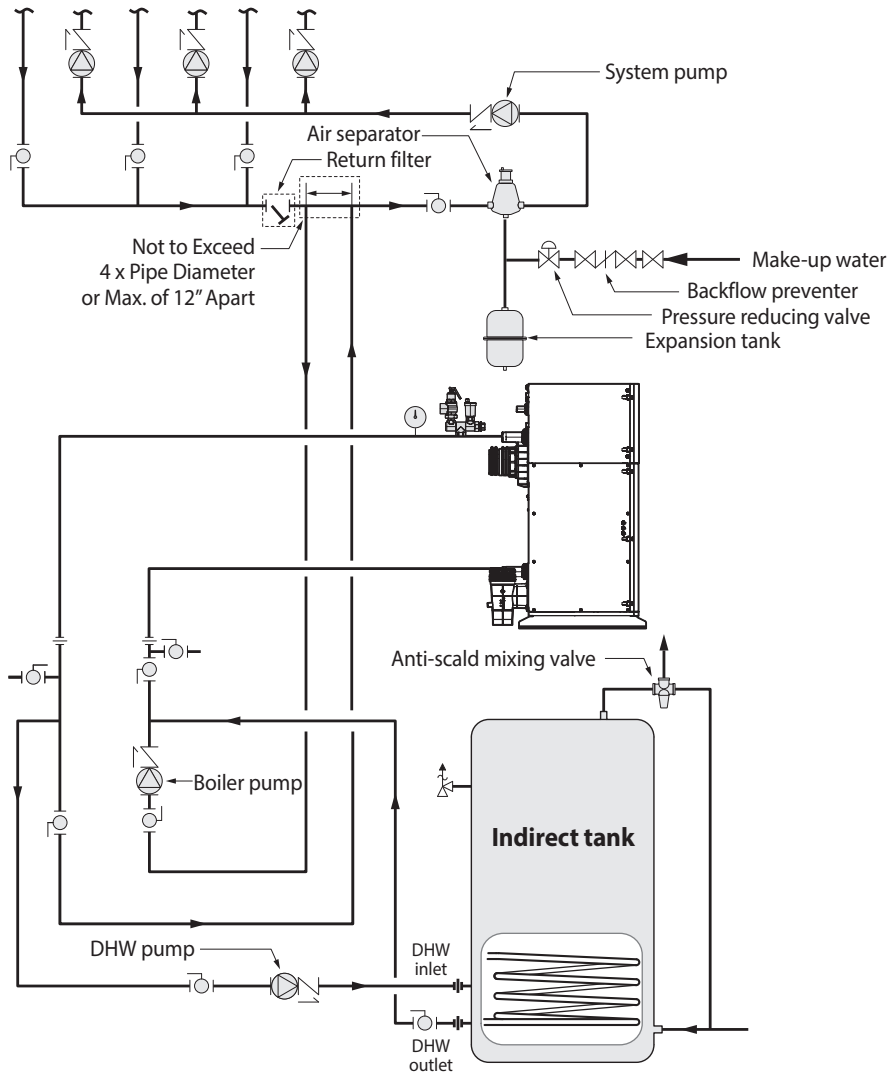

Note

- System application drawings are intended to explain the system piping concept only.
- Install a filter in the system return to remove foreign objects from the system. Foreign objects inside the system may result in abnormal system operation.
- Refer to “3.5.2 System Application - Zone System with Pumps (Primary/Secondary Piping)” on page 37 for make-up water connections and refer to the requirements of your local codes to ensure compliance.
- Refer to the “3.6.7 Wiring Diagram - DHW System with Indirect Tank” on page 47 for wiring connections.

3.6 Examples of Electrical Connections

⚠ WARNING

Electric Shock Hazard

To prevent serious injury or death:

- ALWAYS follow all applicable electrical codes of the local authority having jurisdiction.
- In the absence of such requirements, follow the latest edition of the National Electrical Code (NFPA 70) in the USA or the latest edition of CSA C22.1 Canadian Electrical Code Part 1 in Canada.
- ONLY licensed professionals should connect the electrical components.
- ALWAYS label all wires before disconnecting them when you work on the controls.
- Wiring errors can cause improper and dangerous operation.
- ALWAYS verify proper operation after servicing.

Note

The installation must comply with National Electrical Code and any other national, state, provincial or local codes or regulations. In Canada, CSA C22.1 Canadian Electrical Code Part 1, and any local codes. Wiring must be N.E.C. Class 1. If original wiring as supplied with boiler must be replaced, use only type 105 °C wire or equivalent. Boiler must be electrically grounded as required by National Electrical Code ANSI/NFPA 70 – latest edition.

3.6.1 Accessing the Terminal Strips

⚠ DANGER

Electric Shock Hazard

To prevent serious injury or death:

You must ensure that the boiler is disconnected from the electrical supply before carrying out any servicing inside the boiler and, particularly, on the electric terminal strips.

To access the PCB, carefully follow the steps below:

1. Turn off the power supply to the boiler.
2. Unfasten the 10 latches on the sides of the boiler to remove the front cover (upper and lower).

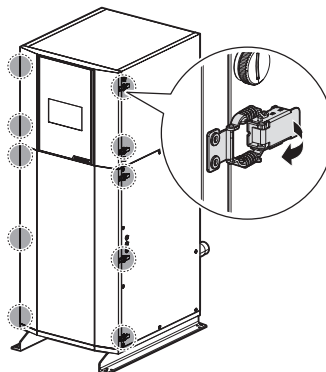

3. Remove the front covers and place them in a safe location to prevent accidental damage.
4. Remove the 6 screws on the controller cover and remove the controller cover.

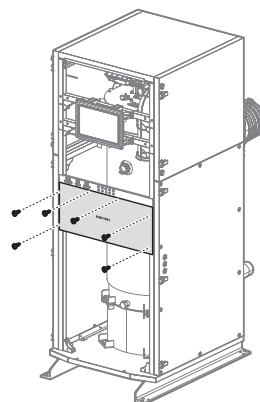

5. Check the terminal board and controller of the main PCB, where external devices are connected inside the controller. For detailed wiring information, refer to "11.2 Wiring Diagram" on page 128.

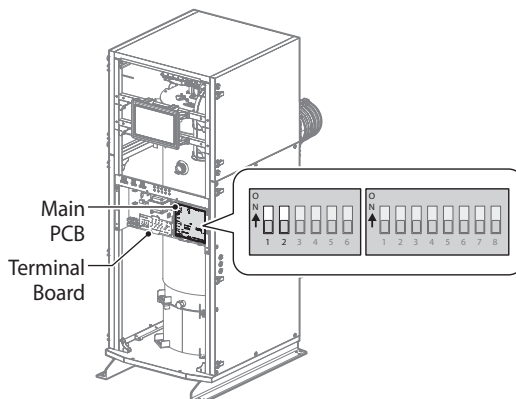

3.6.2 Wiring Diagram - Zone Pump System

The NFB Boilers can operate a heating system with up to 4 zones. The following is the wiring diagram for a zone pump system with 4 zones.

Zone Pump Dry Contact Connections (No 24 VAC Power) and Thermostats without 24 VAC Power

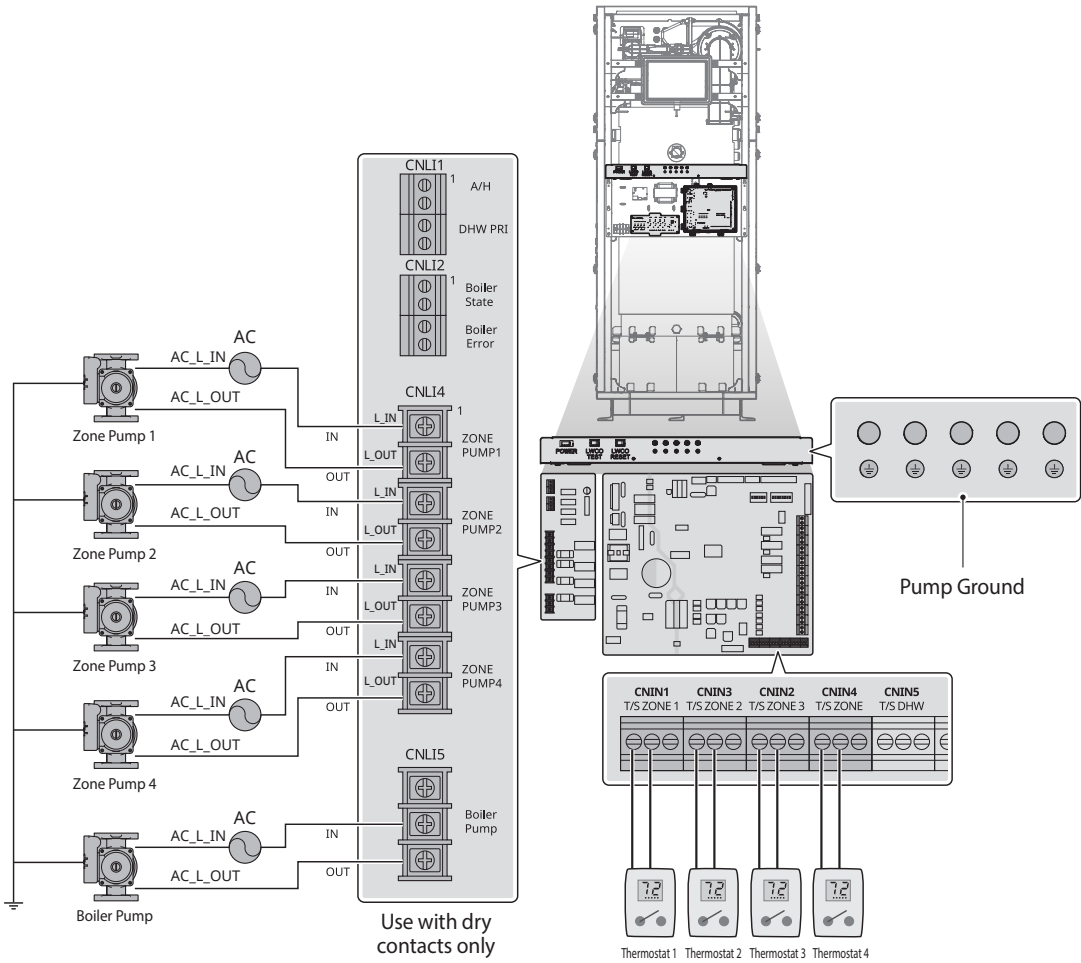

Note

The rated load of the provided dry contacts is designed to be 5 A/120 V for each zone pump output, and 10 A/120 V for the boiler pump.

Zone Pump Dry Contact Connections (No 24 VAC Power) and Thermostats with 24 VAC Power

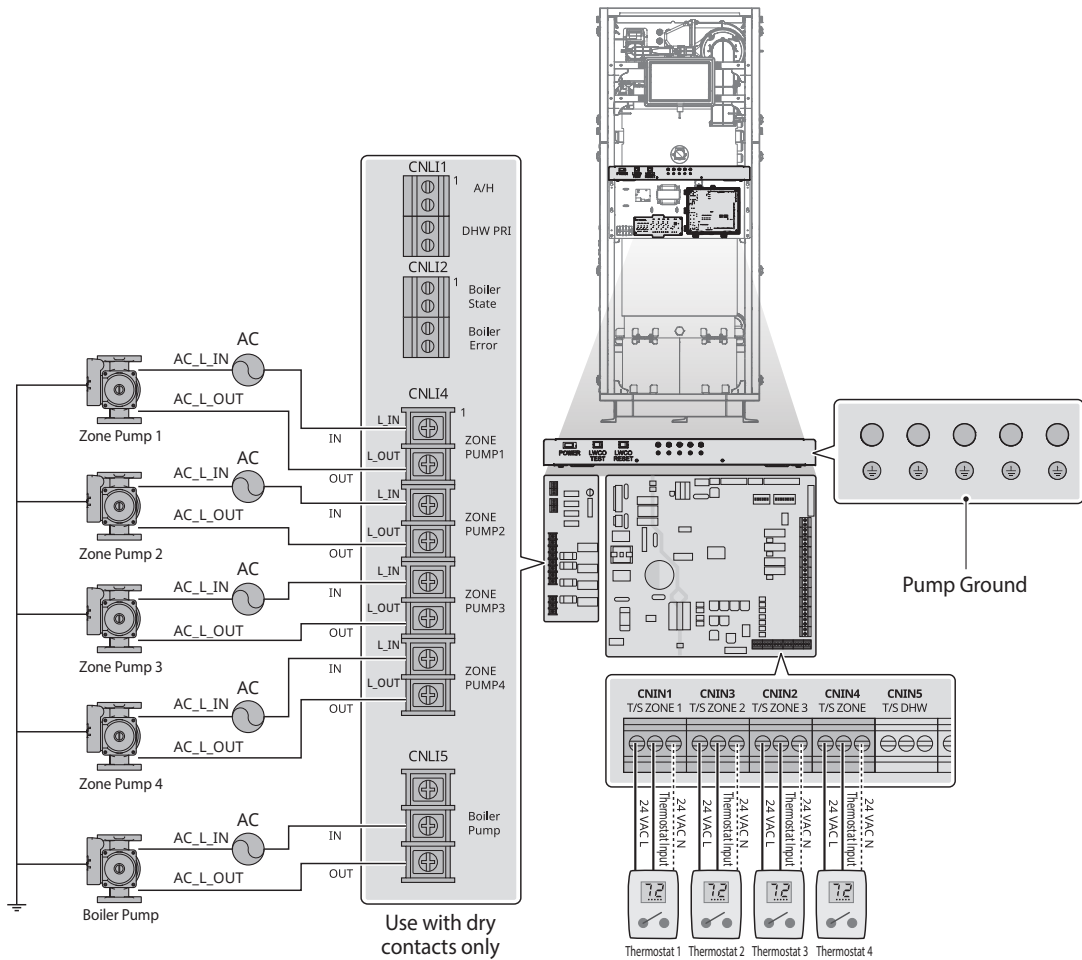

Note

- If you have a 24 V thermostat, connect it to the R & C terminals on the boiler's PCB.
- The C terminals are for optional connections with 24 V thermostat COMMON.
- The rated load of the provided dry contacts is designed to be 5 A/120 V for each zone pump output, and 10 A/120 V for the boiler pump.

3.6.3 Wiring Diagram - Zone Pump System with DHW Tank

The NFB Boilers can operate a heating system with up to 3 zones and 1 DHW Tank. The following is the wiring diagram for a zone pump system with 3 zones and 1 DHW Tank.

Zone Pump Dry Contact Connections (No 24 VAC Power) and Thermostats/DHW Aquastat without 24 VAC Power

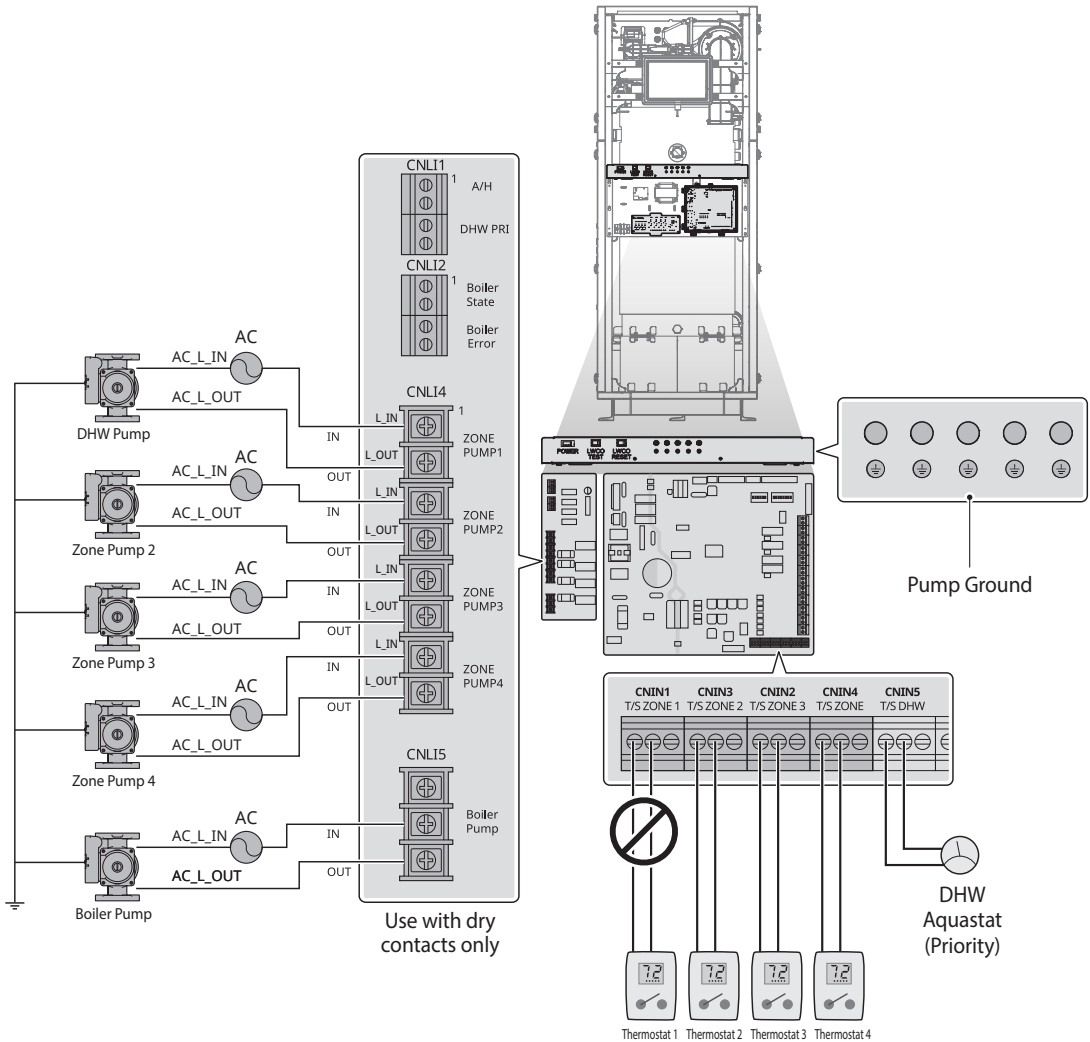

Note

- If the DHW Tank is connected to the terminal, the T/S Zone 1 input is not available.
- Pumps are connected through dry contact connections.
- The rated load of the provided dry contacts is designed to be 5 A/120 V for each zone pump output, and 10 A/120 V for the boiler pump.

Zone Pump Dry Contact Connections (No 24 VAC Power) and Thermostats/DHW Aquastat with 24 VAC Power

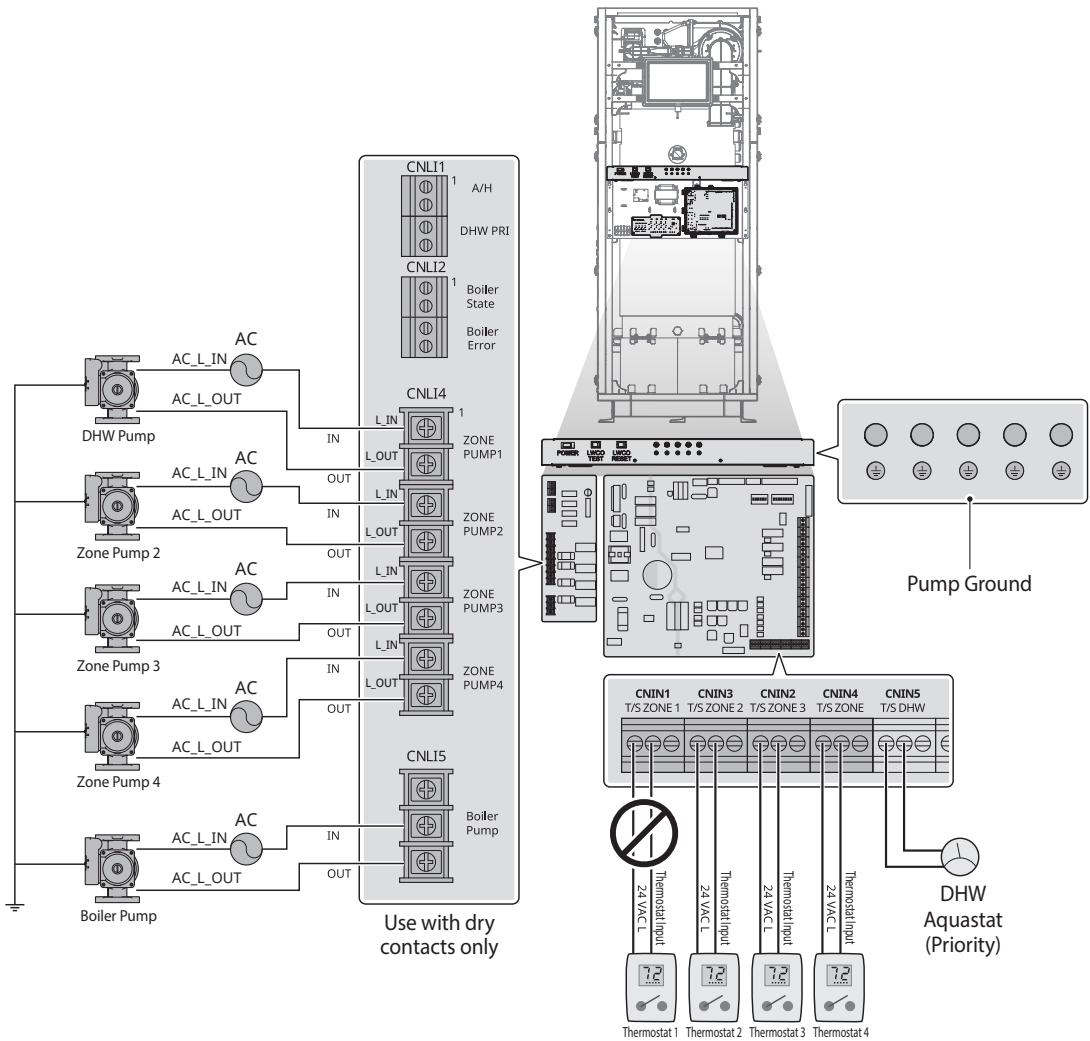

Note

- The C terminals are for optional connections with 24 V thermostat COMMON.
- If the DHW Tank is connected to the terminal, the T/S Zone 1 input is not available.
- Pumps are connected through dry contact connections.
- The rated load of the provided dry contacts is designed to be 5 A/120 V for each zone pump output, and 10 A/120 V for the boiler pump.

3.6.4 Wiring Diagram - the Navien SmartZone +

The Navien Smart Zone + controller may be used with the NFB Boilers to operate a heating system with more than 4 zones.

When Navien boilers are used with a Navien Smartzone+ zone pump controller, an RS-485 data communication link is established through the Ready-link connection. This allows the controller and the boiler to share operational information and to control the zones more efficiently by minimizing unnecessary pump operation.

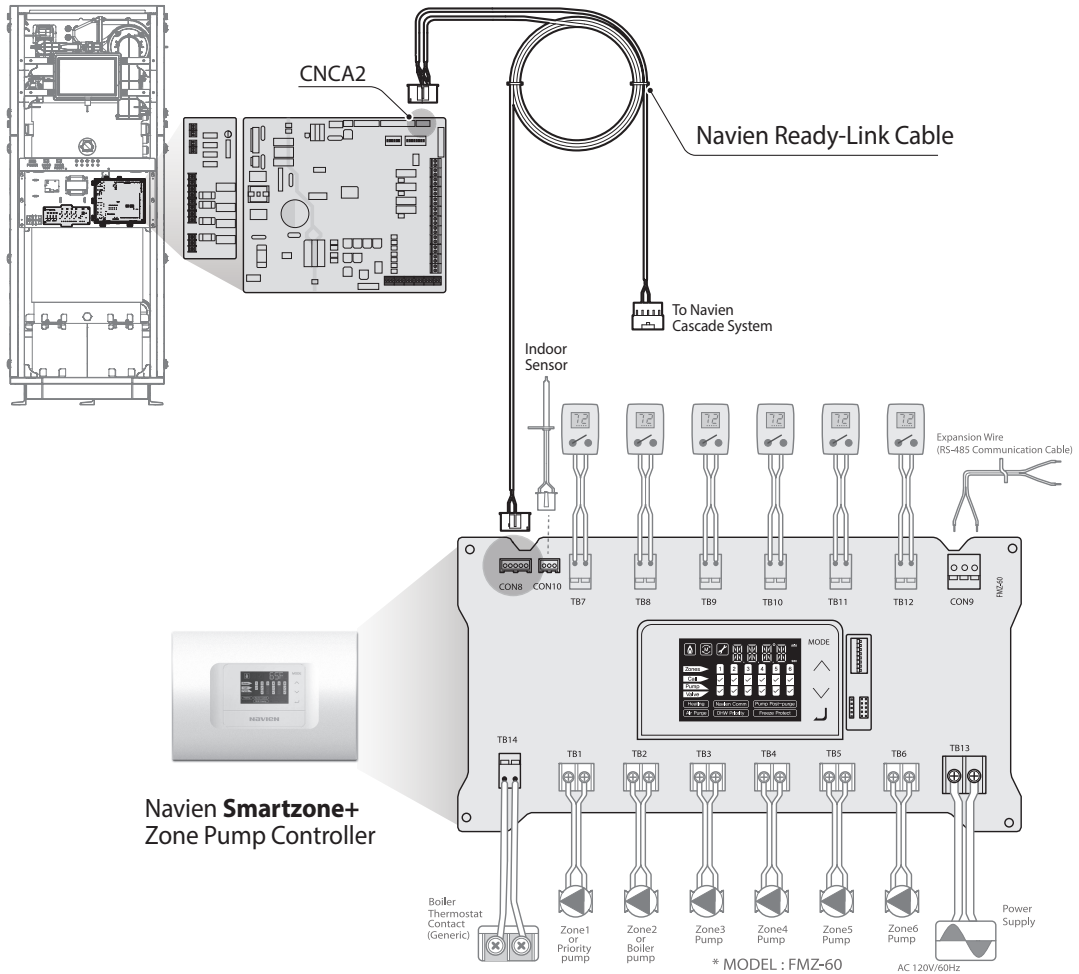

Refer to the user manual that is supplied with the Navien Smartzone+ zone pump controller for details.

Note

The Navien zone controller option in the Ext Connection menu must be set to "ON." To view the Navien zone controller setting, tap the Set button  > **Ext Connection** on the front panel of the NFB700-C boiler.

3.6.5 Wiring Diagram - Generic Zone System with Circulators

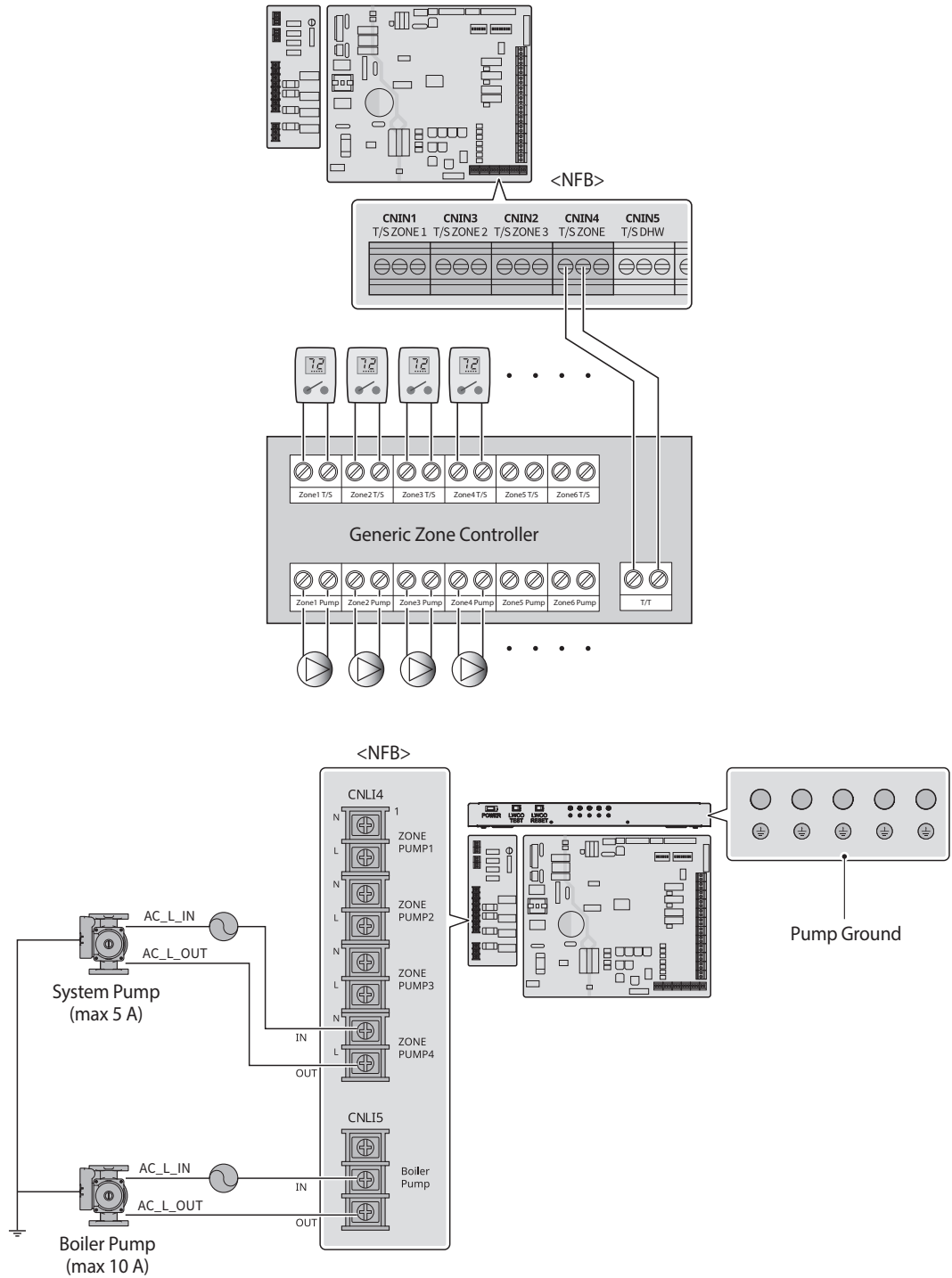

3.6.6 Wiring Diagram - Air Handler

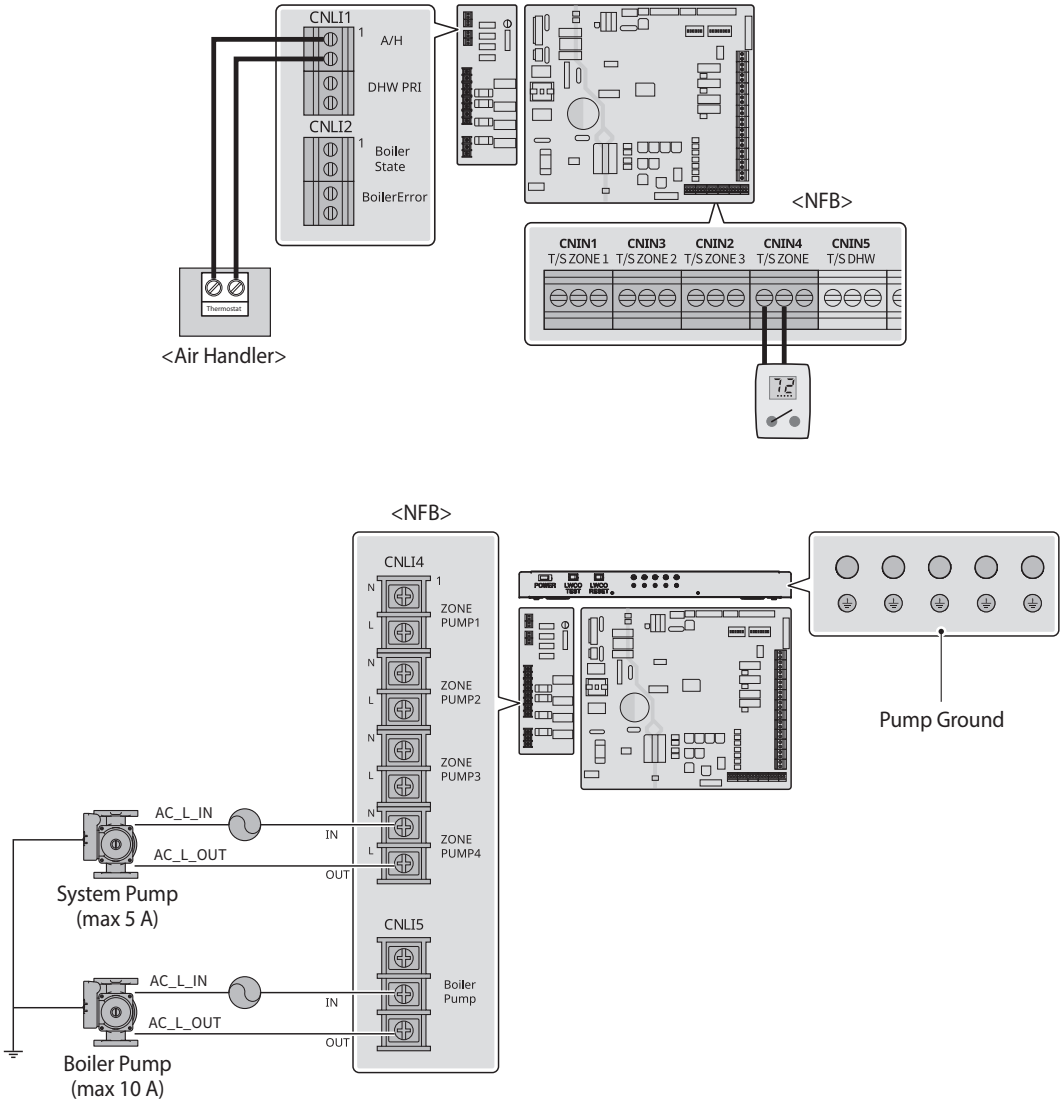

3.6.7 Wiring Diagram - DHW System with Indirect Tank

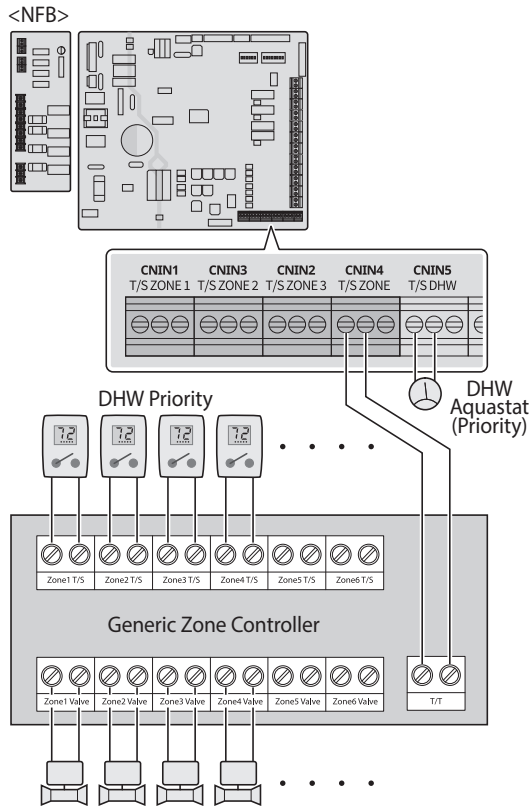

Note When using zone controllers, the DHW demand lines must be connected to the NFB boilers. Either the DHW Aquastat or universal temperature sensor may be used for DHW demand.

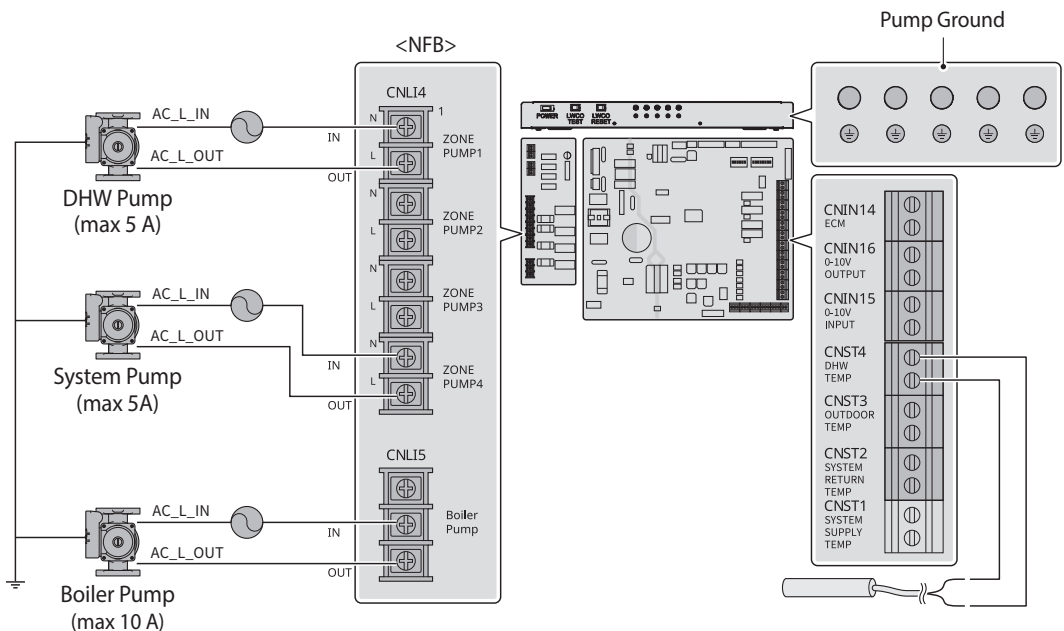

When Connecting the DHW Tank Sensor

The Navien Universal Temperature sensor can be used as a DHW Tank Sensor. When installing the Universal Temperature sensor to the boiler, follow these guidelines:

- This sensor is compatible for use with aquastat immersion wells. Attach an aquastat immersion well to the DHW tank before installing the sensor.
- When installing the sensor to the tank, verify that the sensor is completely inserted into the immersion well.
- Install the included clip on the groove on the immersion well as shown in the illustration.
- Insert the wire through the available eyelet on the clip then wrap it around the clip once to fix the sensor to the well.
- Complete the installation by connecting the wires to the DHW Tank terminals located on the PCB.

- Note**
- When inserting the sensor into the immersion well, heat conductive paste can be used to improve thermal transfer between the two components.
 - The DHW Demand parameter must be set to the correct type. Refer to “10.6.3 Setting the DHW Operation (Indirect)” on page 97 for detailed information.

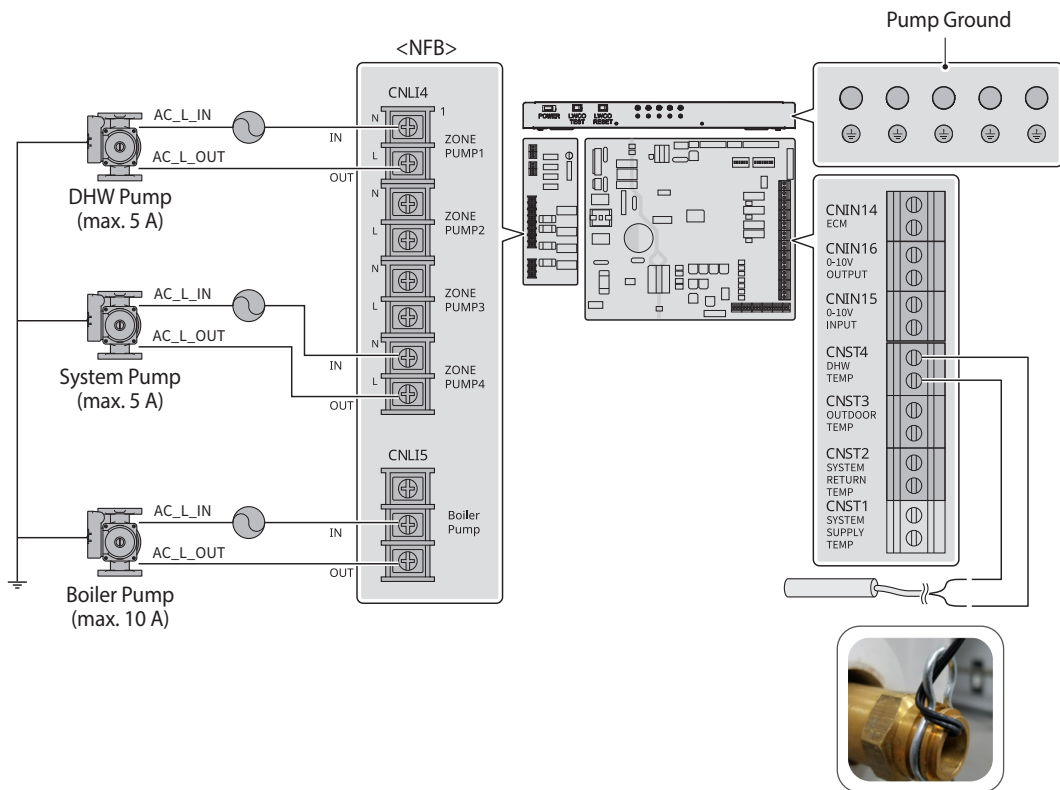

- Note** Use only Navien Universal Temperature sensor.

When installing the DHW Tank Sensor

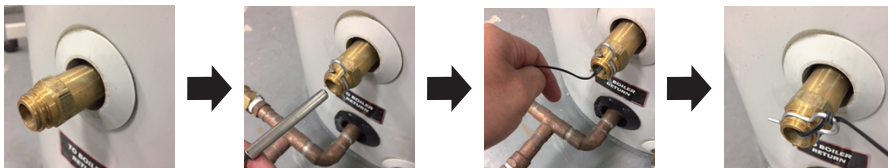

⚠ WARNING

Use only the Navien Universal Temperature sensor (#GXXX001769). The use of other sensors may result in higher water temperatures than expected.

3.6.8 Wiring Diagram - Optional Supply/Return Temperature Sensors

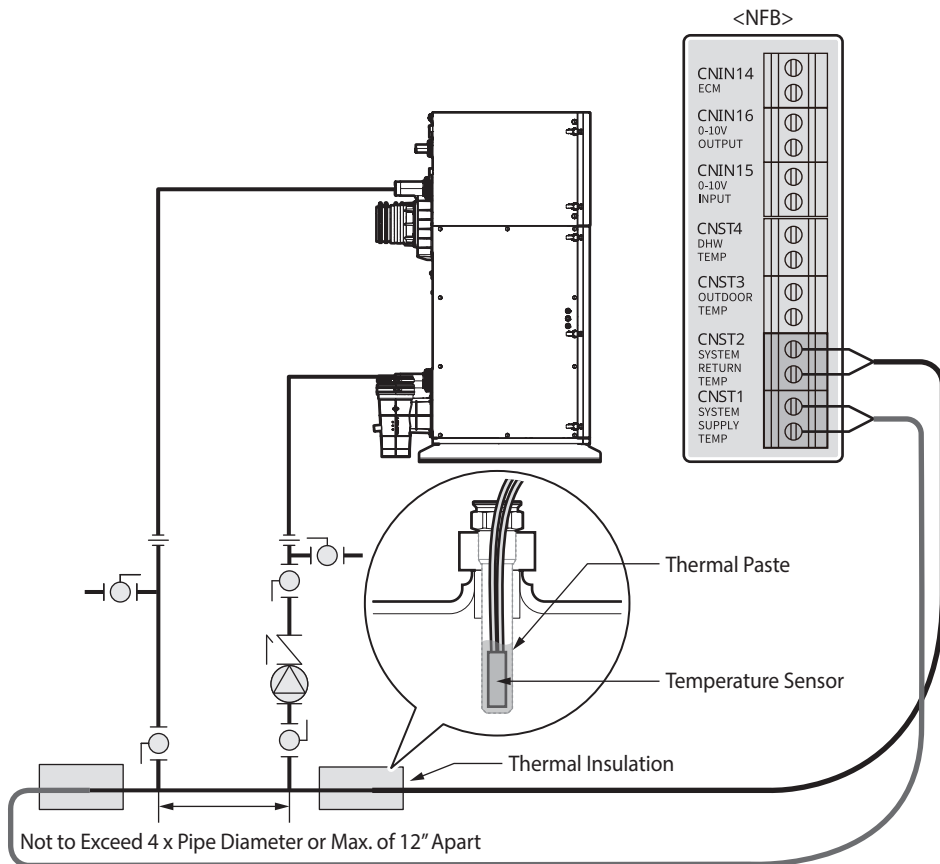

Note

- To control the boiler supply or return water temperature using the external temperature sensors, configure the system accordingly.
- On the front panel, tap the Control button  > **SH Control**, and select one of the SH Control Method options.
- Additional universal temperature sensors are available for purchase where Navien products are sold.
- Refer to "10.6.2 Setting the Space Heating Operation" on page 95 for details.

3.7 Connecting External devices (Field Wiring Guidelines)

To connect external devices to the controller terminals of the main PCB, remove the front cover, and then refer to “10.6.2 Setting the Space Heating Operation” on page 95. For detailed wiring information, refer to “3.6 Examples of Electrical Connections” on page 39.

3.7.1 Thermostat

Connect thermostats to the T/S ZONE1, 2, 3 and 4 terminals (**CNIN1**, **CNIN2**, **CNIN3** and **CNIN4**). Also, install thermostats in walls where they are not interfered with by vents, hot or cold water pipe lines, lighting, televisions, or sunlight.

Note If the Pump1 Setting menu on the SH Control menu is set to **DHW Pump**, Thermostat 1 cannot be used.

3.7.2 DHW Thermostat

Connect an indirect water heater (DHW) thermostat to the T/S DHW terminal (**CNIN5**).

Note

- If the DHW Demand menu on the DHW Control menu is set to **Tank Sensor**, the DHW thermostat is ignored.
- If the Pump1 Setting menu on the SH Control menu is set to **Zone1 Pump**, the DHW thermostat is ignored.

3.7.3 DHW Tank Sensor

Connect the Navien universal temperature sensor (#GXXX001769) to the DHW TANK terminal (**CNST4**).

The boiler tank temperature can be adjusted if a DHW tank sensor is installed. If the tank temperature decreases 5°F (3°C) below the set temperature, the boiler starts and stops operating when the set temperature is reached. The values of the DHW Demand On/Off Differential can be adjusted by setting the parameters.

Note

- If the DHW Demand menu on the DHW Control menu is set to **Aquastat**, the DHW tank sensor is ignored.
- If the Pump1 Setting menu on the SH Control menu is set to **Zone1 Pump**, the DHW tank sensor is ignored.
- If the Navien universal temperature sensor (#GXXX001769) is not compatible with the DHW tank, use a DHW thermostat to control the boiler.

3.7.4 System Supply/Return Sensor

Connect the system supply/return sensors to the SYSTEM SUPPLY terminal (**CNST1**) and the SYSTEM RETURN terminal (**CNST2**).

If the Navien universal temperature sensor (#GXXX001769) is installed to the secondary loop, the system supply unit temperature can be adjusted. It controls the boiler's heat and maintains the system supply temperature at the set temperature.

Note To select the space heating control method, tap the Control button  > **SH Control** on the screen, and then select **Sys Supply** (System Supply Temperature) or **Sys Return** (System Return Temperature) on the SH Control Method menu.

3.7.5 Outdoor Temperature Sensor

Connect the Navien outdoor temperature sensor to the OUTDOOR terminal (**CNST3**). Also, install the sensor away from sources of heat or sunlight. The sensor should be installed on the north or northeast side of the building in a way that is reading ambient air temperature.

3.7.6 Flow Switch

Remove the jumper cable connected to the FLOW SW terminal (**CNIN8**) and connect a flow switch to the FLOW SW terminal (**CNIN8**). The flow switch is installed at the bottom of the boiler and is used to check water flow through the boiler.

3.7.7 Manual Reset Safety Switch

Connect an external safety device to the MANUAL terminal (**CNIN11**). Only external safety devices with relay output contacts may be connected. Do not connect direct power to these terminals. Even if an error from the connected external safety device occurs, the error is cleared with a manual reset.

Note To select the contact type for the connected external safety device, tap the Set button (⚙️) > **Ext Connection** on the screen, and then select **N-Open** (Normal open type) or **N-Closed** (Normal closed type).

3.7.8 Auto Reset Safety Switch

Connect an external safety device to the AUTO terminal (**CNIN10**). Only external safety devices with relay output contacts are available. Do not connect direct power to these terminals. An error alert from the connected external safety device is released automatically based on the connected external safety device settings.

Note To select the contact type for the connected external safety device, tap the Set button (⚙️) > **Ext Connection** on the screen, and then select **N-Open** (Normal open type) or **N-Closed** (Normal closed type).

3.7.9 Modbus/BACnet

If a Modbus/BACnet gateway is installed, connect the RS-485 cables to the 3-pin terminal block located on the right side of the front panel. For detailed wiring information, refer to the Modbus/BACnet Installation manual.

- Note**
- To provide sufficient communication quality and sensitivity, use twisted pair cables such as UTP or CAT5 cables.
 - To enable the Modbus RTU feature, tap the EMS button (🏠) > **EMS Set** on the screen, and then select Enabled on the Modbus RTU menu.
 - To provide sufficient communication quality and sensitivity, use twisted pair cables such as UTP or CAT5 cables.

3.7.10 0-10 V VDC Input

Connect a 0-10 V VDC input signal to the 0-10 V IN terminal (**CNIN15**), if the BMS system requires 0-10 V signals to control the set temperature.

Note If the BMS Status menu on the EMS Set menu is set to **Enabled**, the set temperature is automatically controlled based on the input signals.

3.7.11 ECM VDC Output

The 0–10 V signal output can be used to control the speed of the boiler pump. Connect this output to the 0–10 V input of the boiler pump speed control device.

3.7.12 0-10 V VDC Output

Depending on the space heating control methods, the supply or return water temperature can be measured with 0-10 V signal output. The current temperature in the BMS system can be monitored using this signal output.

3.7.13 Air Handler

The air handler provides output through the boiler controller depending on the space heating operation status. If space heating is in operation, the air handler's contact is on. If the space heating is not in operation, the air handler's contact is off. When using an air handler, set the air handler to operate during the operation of space heating only.

3.7.14 DHW Priority

The DHW priority provides output through the boiler controller. When the DHW mode is on while there is a space heating demand, the DHW priority's contact is on. Other than during this status, the DHW priority's contact is off. Use a DHW priority to check the status of the zone controller or DHW priority.

3.7.15 Boiler State

The boiler state contact outputs from the boiler controller. The boiler state contact is turned on during combustion. Other than this status, the boiler state contact is turned off. Use a boiler state contact to check the boiler status.

3.7.16 Boiler Error

The boiler error contact provides a boiler error status. The boiler error contact is turned on when an error occurs. Other than this, the boiler error contact is turned off. Use a boiler error contact to check the boiler error status.

3.7.17 Louver Switch Input

Check if louver is completely open, and then check if louver switch is closed to start ignition.

Note

- If ignition is already in progress, checking the louver switch is not required.
- Ignition is available only when the louver switch is closed.

3.7.18 Louver

A louver is a device used to supply combustion air. The louver contact is turned on when the louver switch input is normal (not in an error state) and both heat demand is present and the fan is operating.

4. Connecting the Gas Supply

⚠ WARNING

- Before connecting the gas supply, determine the gas type and pressure for the boiler by referring to the rating plate. Use only the same gas type indicated on the rating plate. Using a different gas type will result in abnormal combustion and malfunction of the boiler. Gas supplies should be connected by a licensed professional only.
- To avoid damaging the connectors on the boiler, use two wrenches when tightening piping to the boiler. Use one wrench to prevent the boiler's connector from turning, and use the other wrench to tighten the connection. Damaged connectors may result in system leaks.
- Properly support the piping with hangers. Do not allow the piping to be supported by the boiler or its accessories.
- Ensure that the gas piping is protected from physical damage and freezing where required. Failure to follow these instructions could result in gas leakage and result in fire, explosion, property damage, severe personal injury, or death.
- The appliance and its gas connection must be leak tested before placing the appliance in operation.
- To avoid danger from explosion and fire, do not use a flame to check for a gas leak. Perform a bubble test on the joints to check for gas leaks. If a leak exists, bubbles will form at the leaking joint. A gas leak could result in substantial property damage, severe personal injury, or death.
- Immediately turn off the boiler and stop the gas supply if a gas leak is detected. Perform a bubble test to find the leak and repair the leak immediately. Do not start the boiler again until the leak is repaired. Operating the boiler with a gas leak could result in substantial property damage, severe personal injury, or death.
- This boiler cannot be converted from natural gas to propane or vice versa without a Navien gas conversion kit. Do not attempt a field conversion of this boiler without a Navien gas conversion kit. Doing so will result in dangerous operating conditions and will void the warranty.

Note

- The Gas Conversion Kit is located inside the boiler cabinet. You will need to remove the front cover to access the Propane Gas & High Altitude Conversion Kit.
- Before installing water pipes on the boiler, thoroughly inspect the area to ensure there is no interference between the water pipes and gas supply line.

Navien recommends connecting the boiler as the first appliance downstream of the gas meter, to ensure a sufficient gas supply.

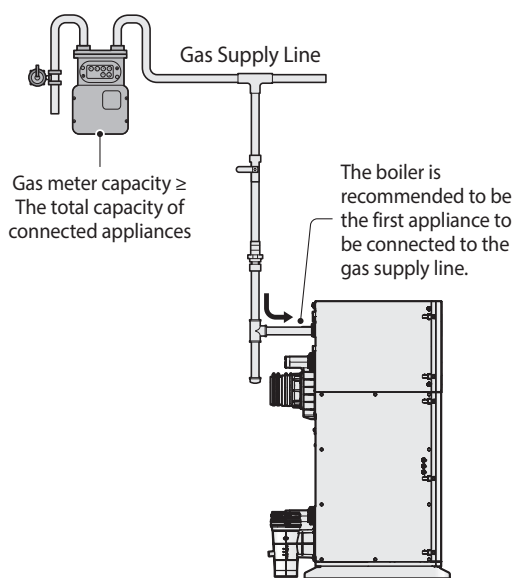

To connect the gas supply:

1. Determine the gas type and pressure for the boiler by referring to the rating plate.
2. Perform a pressure test on the main gas supply line.
3. Purge the gas line of any debris.
4. Determine the proper size and type for the gas line. Refer to the tables that follow.

Note

Refer to the instructions provided with the gas regulator for the minimum pipe distance between the regulator and the appliance.

5. Install certified full port valves on the gas supply line and boiler.
6. Connect the gas supply line.
7. Test the supply line, all connection points, and the boiler for gas leaks.

Note Tighten the boiler connection valves with care to avoid damage.

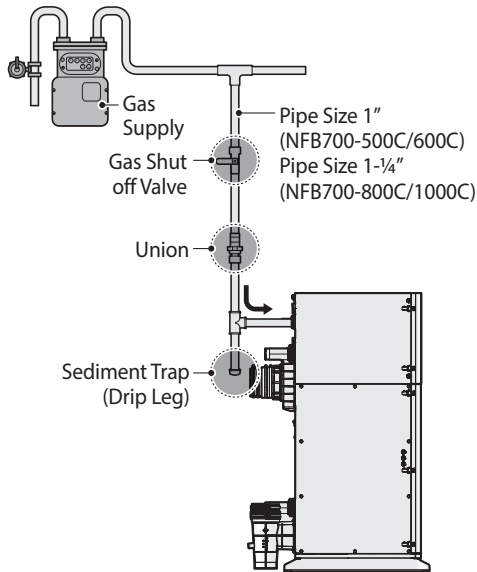

NOTICE

- Install a manual gas shut-off valve between the gas supply line and the boiler.
- A sediment trap must be provided upstream of the gas controls.

Note

- Tighten the boiler connection valves with care to avoid damage.
- The gas connection fitting on NFB700-500C/600C is 1 in, and on NFB700-800C/1000C is 1-1/4 in.
- 1" or 1-1/4" in rigid pipe can be used; refer to the sizing tables on the proceeding pages for limitations. DO NOT use 1" or 1-1/4" in corrugated connectors or tubing as noise may occur.

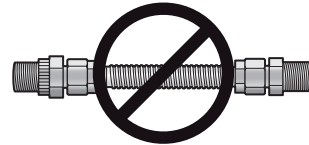

Corrugated Connector

- Navien recommends the installation of a union on the gas supply line close to the boiler, to facilitate any future maintenance or service.

NOTICE

Prior to using an excess flow valve (EFV) in the gas line, check the manufacturer's minimum and maximum flow capacity rating. An improperly sized EFV will not allow for a full flow of gas to the boiler and may cause improper operation.

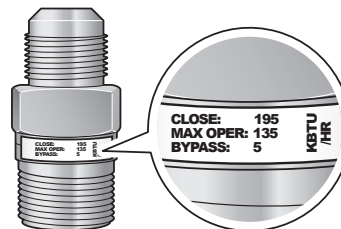

Excess Flow Valve

Typical propane gas piping examples:

2 Stage System with Multiple Regulators (Recommended)

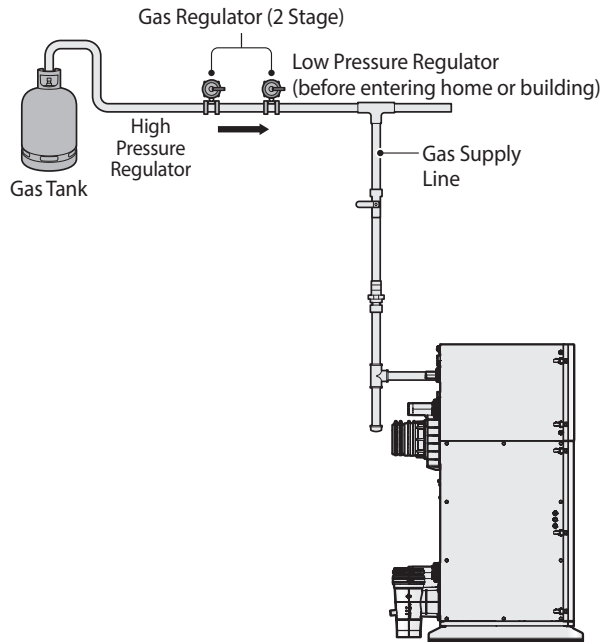

Single Regulator System

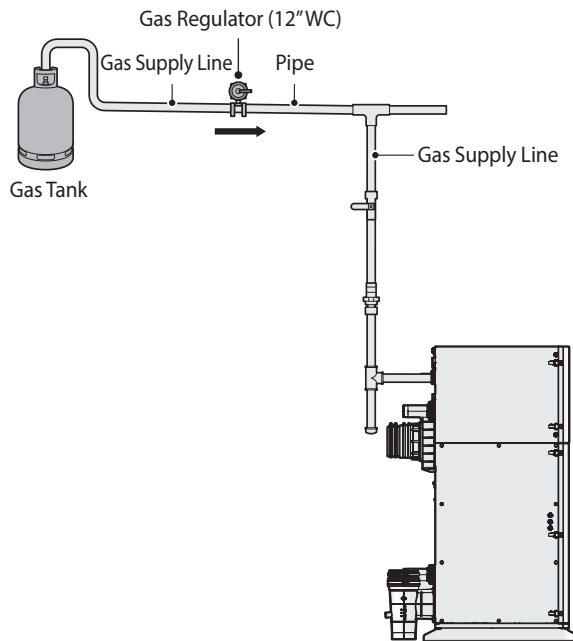

4.1 Gas Pipe Sizing Tables

The following tables are referenced from the latest version of the National Fuel Gas Code and are for reference only. Please consult the gas pipe manufacturer for actual pipe capacities.

Maximum Natural Gas Delivery Capacity

In Cubic Feet (ft³) per Hour (0.60 Specific Gravity; 0.5 in WC Pressure Drop). Contact your gas supplier for BTU/ft³ ratings. Use 1,000 BTU/ft³ for simplified calculations. This table is recommended for supply pressures less than 6 in WC.

Pipe Size	Length (including fittings)										
	10 ft (3 m)	20 ft (6 m)	30 ft (9 m)	40 ft (12 m)	50 ft (15 m)	60 ft (18 m)	70 ft (21 m)	80 ft (24 m)	90 ft (27 m)	100 ft (30 m)	125 ft (38 m)
¾ in	360	247	199	170	151	137	126	117	110	104	92
1 in	678	466	374	320	284	257	237	220	207	195	173
1 ¼ in	1,390	957	768	657	583	528	486	452	424	400	355
1 ½ in	2,090	1,430	1,150	985	873	791	728	677	635	600	532
2 in	4,020	2,760	2,220	1,900	1,680	1,520	1,400	1,300	1,220	1,160	1,020
2 ½ in	6,400	4,400	3,530	3,020	2,680	2,430	2,230	2,080	1,950	1,840	1,630
3 in	11,300	7,780	6,250	5,350	4,740	4,290	3,950	3,670	3,450	3,260	2,890
4 in	23,100	15,900	12,700	10,900	9,660	8,760	8,050	7,490	7,030	6,640	5,890

In Cubic Feet (ft³) per Hour (0.60 Specific Gravity; 3.0 in WC Pressure Drop). Contact your gas supplier for BTU/ft³ ratings. Use 1,000 BTU/ft³ for simplified calculations. This table is recommended for supply pressures of 6 in WC or greater.

Pipe Size	Length (including fittings)										
	10 ft (3 m)	20 ft (6 m)	30 ft (9 m)	40 ft (12 m)	50 ft (15 m)	60 ft (18 m)	70 ft (21 m)	80 ft (24 m)	90 ft (27 m)	100 ft (30 m)	125 ft (38 m)
¾ in	949	652	524	448	397	360	331	308	289	273	242
1 in	1,787	1,228	986	844	748	678	624	580	544	514	456
1 ¼ in	3,669	2,522	2,025	1,733	1,536	1,392	1,280	1,191	1,118	1,056	936
1 ½ in	5,497	3,778	3,034	2,597	2,302	2,085	1,919	1,785	1,675	1,582	1,402
2 in	10,588	7,277	5,844	5,001	4,433	4,016	3,695	3,437	3,225	3,046	2,700
2 ½ in	16,875	11,598	9,314	7,971	7,065	6,401	5,889	5,479	5,140	4,856	4,303
3 in	29,832	20,503	16,465	14,092	12,489	11,316	10,411	9,685	9,087	8,584	7,608
4 in	43,678	30,020	24,107	20,632	18,286	16,569	15,243	14,181	13,305	12,568	11,139

Maximum Liquefied Propane Delivery Capacity

In Thousands of BTU/H (0.5 in WC pressure drop)

Pipe Size	Length (including fittings)												
	10 ft (3 m)	20 ft (6 m)	30 ft (9 m)	40 ft (12 m)	50 ft (15 m)	60 ft (18 m)	80 ft (24 m)	100 ft (30 m)	125 ft (38 m)	150 ft (45 m)	175 ft (53 m)	200 ft (60 m)	250 ft (76 m)
¾ in	608	418	336	287	255	231	212	197	185	175	155	140	129
1 in	1,150	787	632	541	480	434	400	372	349	330	292	265	243
1 ¼ in	2,350	1,620	1,300	1,110	985	892	821	763	716	677	600	543	500
1 ½ in	3,520	2,420	1,940	1,660	1,480	1,340	1,230	1,140	1,070	1,010	899	814	749
2 in	6,790	4,660	3,750	3,210	2,840	2,570	2,370	2,200	2,070	1,950	1,730	1,570	1,440

4.2 Measuring the Inlet Gas Pressure

WARNING

The inlet gas pressure should be checked by a LICENSED PROFESSIONAL ONLY. The boiler cannot function properly without sufficient inlet gas pressure.

- The inlet gas pressure must be maintained between 3.5 in and 10.5 in WC for natural gas and between 8.0 in and 13.0 in WC for liquefied propane.
- The appliance and its individual shutoff valve must be disconnected from the gas supply piping system during any pressure testing of that system at test pressures in excess of ½ psi (3.5 kPa).
- The appliance must be isolated from the gas supply piping system by closing its individual manual shutoff valve during any pressure testing of the gas supply piping system at test pressures equal to or less than ½ psi (3.5 kPa).

Note If gas pressure is out of the acceptable range or an excessive pressure drop is observed, contact the gas supplier or a qualified installer to supply proper gas pressure to the unit.

To measure the inlet gas pressure:

1. Shut off the manual gas valve on the gas supply line.

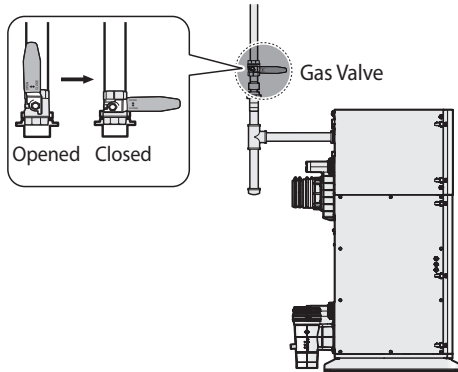

2. Turn on the boiler, and then tap the Set button  > **Service** > **Setting Op-Mode** on the front panel.
3. To select the operation mode, tap **2Step MAX**.
4. Tap **Close** to return to normal operation mode.
5. Run space heating. The gas in the gas supply line will be purged.
6. Leave the boiler on until the boiler shuts down due to a lack of gas supply, and then turn off the boiler.
7. Unfasten the 4 latches on the sides of the boiler to remove the upper-front cover and gain access to the internal components.

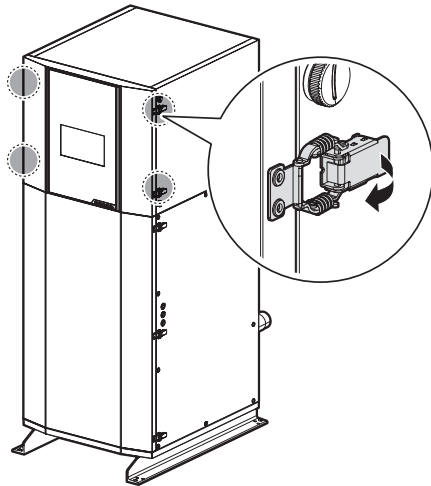

8. Remove the upper-front cover and place it in a safe location to prevent accidental damage.
9. Connect a manometer to the pressure port of the gas control valve. Reset the manometer to zero before use.

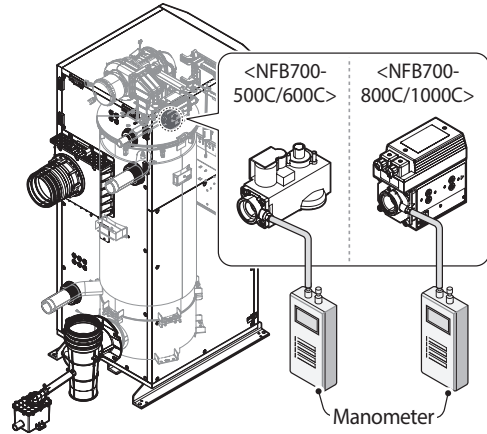

10. Re-open the manual gas valve and check for leaks.
11. Activate multiple zones to ramp the boiler up to its maximum firing rate.
12. When the boiler reaches its maximum firing rate, check the inlet gas pressure reading on the manometer. The gas pressure must fall within the ranges specified on page 7.

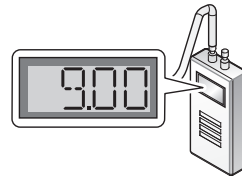

5. Venting for Combustion Air

WARNING

Carbon Monoxide Hazard

The installation of carbon monoxide detectors may be required in your area for the boiler or other gas fired appliances. Check applicable codes for the installation location of the boiler.

Carbon monoxide detectors should comply with NFPA 720 and be ANSI/UL 2034 listed and IAS certified.

Additional Guidelines for Combustion Air

- Combustion air piping to the outside is recommended. (Direct Venting)
- The boiler may be installed with a single pipe carrying the flue products to the outside while using combustion air from the equipment room. In order to use the room air venting option on page 63, specific conditions and considerations must be followed.

WARNING

To prevent death, serious injury or property damage:

- Do not install the boiler or combustion air piping in areas with contaminated air (e.g. high levels of dust, sawdust, sand, flour, aerosols, fluorine or chlorine compounds).
- DO NOT allow liquids or vapors from pool, laundry products, or common household cleaning products to enter the boiler. These can cause serious product damage and can even result in flue gas leakage in extreme cases.
- ALWAYS check for areas and products listed in the following tables before installing the boiler or air inlet piping.
- ALWAYS remove contaminants or relocate air inlet and vent terminations to other clean areas. Navien recommends regular filter cleaning and maintenance in these areas.

Note

The warranty does not cover damage caused by air contaminants.

Corrosive Contaminants

Muriatic acid/hydrochloric acid
Refrigerant leaks
Chlorine-type bleaches, detergents, and cleaning solvents found in household laundry rooms
Varnish removers or paint
Adhesives used to fasten building products and other similar products
Chlorine-based swimming pool chemicals
Permanent wave solutions
Anti-static fabric softeners used in clothes dryers
Calcium chloride used for thawing
Spray cans containing chloro/fluorocarbons
Cements and glues
Sodium chloride used for water softening
Chlorinated waxes/cleaners

Corrosive Sources

Remodeling areas
Refrigeration repair shops
New building construction
Metal fabrication plants
Laundry areas and establishments/dry cleaning
Swimming pools
Auto body shops
Furniture refinishing areas and establishments
Garages with workshops
Plastic manufacturing plants
Beauty shops
Photo processing plants

5.1 Venting the Boiler

DANGER

This appliance is certified as a Category IV appliance and requires a special venting system. The vent system operates with a positive pressure in the pipe.

To prevent serious injury or death:

- ALWAYS vent exhaust gases directly outdoors using the vent materials and following these instructions.
- DO NOT connect vent connectors serving appliances vented by natural draft into any portion of mechanical draft systems operating under positive pressure.

WARNING

Improper venting of the boiler can result in excessive levels of carbon monoxide and can lead to serious injury or death.

This boiler must be vented in accordance with the “Venting of Equipment” section of the latest edition of the ANSI Z223.1/NFPA 54 Natural Fuel Gas Code in the USA and/or the “Venting systems and air supply for boilers” section of the latest version of the CAN/CGA B149.1 Natural Gas and Propane Installation Code in Canada, as well as all applicable local building codes and regulations.

To prevent serious injury or death:

- ONLY licensed professionals should install venting.
- ALWAYS follow all regulations, codes, and instructions when venting the boiler.
- ALWAYS seal the venting system gastight to prevent flue gas leakage and carbon monoxide emissions.
- The building owner is responsible to maintain the exhaust and intake terminations free of snow, ice, or other potential blockages, as well as scheduling routine maintenance.

The boiler must be properly vented to ensure a constant supply of clean intake air and to ensure that exhaust air is properly removed from living areas. When venting the boiler, follow these guidelines:

- Do not install the boiler in areas with contaminated air (containing a high level of dust, sawdust, sand, flour, aerosols, or any other such airborne contaminants), as contaminants can cause operational problems. The warranty does not cover damage caused by contaminants in the installation area. If you must install the boilers in an area with contaminated air, use direct venting to supply air from outside the building. We recommend regular filter cleaning and maintenance in these areas.
- For best results, keep the venting system as short and straight as possible.
- Locate the boiler as close as possible to the vent termination.
- Do not connect the boiler vent to a vent for any other gas boiler or vent stack.
- For horizontal runs, slope the horizontal section upward toward the vent termination at a rate of $\frac{1}{4}$ in per foot (2% slope).
- Create an airtight seal at each joint in the exhaust and intake air pipes from the boiler collar to the vent termination (see below).

Note

Do not cover any non-metallic vent materials with thermal insulation.

Connecting the Pipe to the Vent Collar

Note Do not use primer or cement on the appliance connection.

⚠ WARNING

ALWAYS properly cut the pipe at a 90° angle and deburr the vent pipe before installing so the pipe is fully connected to the exhaust gas vent fitting.

Use water (NOT grease) to lubricate the end of the vent pipe before inserting into the collar.

ALWAYS insert the vent pipe 4-³/₄" (120 mm) into the appliance exhaust collar using a twisting motion until the end reaches the bottom of the socket.

If flue gas leaks, inhalation of carbon monoxide may result in serious injury or death.

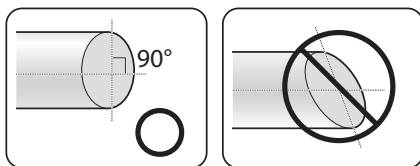
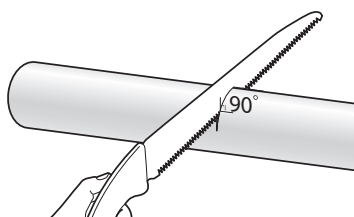

⚠ WARNING

NEVER start the vent run with a **street elbow** at the vent collar to prevent serious injury or death. Using an elbow directly at the collar will not allow for a tight seal between the appliance and the vent pipe.

ALWAYS use a length of straight pipe when starting the vent run.

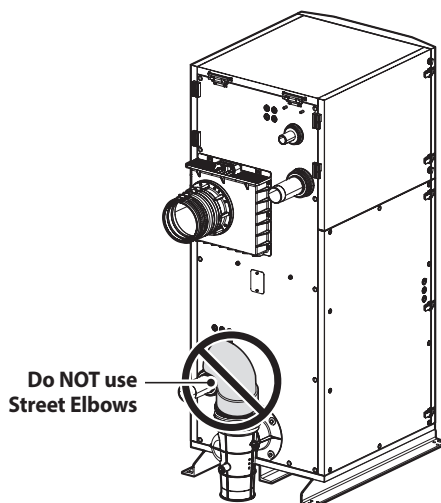

- To avoid moisture and frost build-up and to maintain clearances to openings on adjacent homes, 45° elbows, 90° elbows, or tees may be attached to the end of the termination vent pipe to direct the exhaust plumes away from buildings, as long as the total allowable vent lengths, maximum number of elbows, and distances to air intake restrictions are observed.
- Do not store hazardous or flammable substances near the vent termination.
- If this boiler will be installed in areas where snow is known to accumulate, protect the vent termination from blockage.
- Ensure that the vent termination is at least 12 in (305 mm) above the highest anticipated snow line, or as required by local codes, whichever is greater.
- Support the vent pipe with hangers at regular intervals or as required by local codes. Exhaust and intake air pipes must be supported at least every 4 ft (1.2 m).
- The vent for this appliance shall not terminate over public walkways; or near soffit vents or crawl space vents or where condensate or vapor could create a nuisance or hazard or cause property damage; or where condensate or vapor could cause damage or could be detrimental to the operation of regulators, relief valves, or other equipment.

⚠ WARNING

ALWAYS turn on the boiler and test for gas leaks along the exhaust vent using a bubble test kit.
If the connections leak, carbon monoxide in the flue gas may cause serious injury or death.

5.2 Selecting a Vent Type

All Navien boilers are Category IV appliances and prepared at the factory to be direct vented (sealed combustion). Navien recommends direct air vent installations whenever possible to avoid back drafting cold air through the boiler unit. If you cannot use a direct vent, ensure that an ample supply of make-up air is available in the installation location.

Navien also recommends installing a new vent system with this appliance. If reusing an existing vent system, thoroughly inspect it for punctures, cracks, or blockages prior to connecting it to the boiler.

Direct Venting

The boiler uses a 4 in or 6 in diameter exhaust and a 4 in or 6 in diameter air intake ducts. To ensure the draw of air directly from and exhaust of air directly to the outside of the building, create an airtight seal from the boiler collar to the vent termination.

Intake materials can be made of ABS, PVC, CPVC, PP, galvanized or stainless steel, corrugated aluminum or any other such materials. If you use a corrugated material, ensure that there is not inadvertent crimping of, or damage to, the intake air pipe.

When using direct venting, maintain the following venting clearances, as required by **ANSI Z21.10.3 and the National Fuel Gas Code, ANSI Z223.1/NFPA 54, and CAN/CGA B149.1 Natural Gas and Propane Installation Code:**

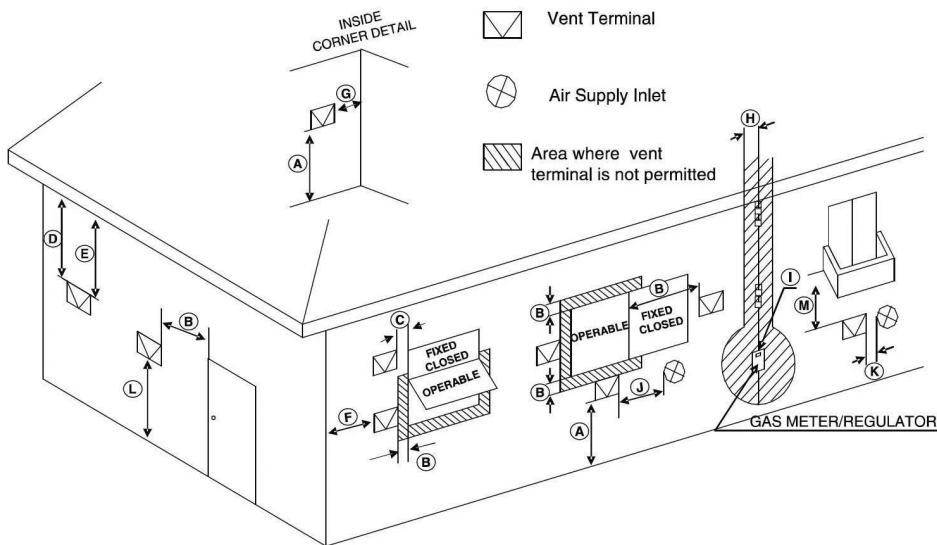

Ref	Description	Canadian Direct Vent Installations ¹	US Direct Vent Installations ²
A	Clearance above grade, veranda, porch, deck, or balcony	12 in (30 cm)	12 in (30 cm)
B	Clearance to window or door that may be opened	36 in (91 cm)	12 in (30 cm)
C	Clearance to permanently closed window	0 in (0 cm) ⁵	0 in (0 cm) ⁵
D	Vertical clearance to ventilated soffit located above the terminal within a horizontal distance of 2 ft (61 cm) from the center line of the terminal	Equal or greater than soffit depth ^{4 5}	Equal or greater than soffit depth ^{4 5}
E	Clearance to unventilated soffit	3 ft (91 cm)*	3 ft (91 cm)*
F	Clearance to outside corner	2 ft (61 cm)*	2 ft (61 cm)*
G	Clearance to inside corner	12 in (30 cm)*	12 in (30 cm)*
H	Clearance to each side of center line extended above meter/regulator assembly	3 ft (91 cm) within a height 15 ft (4.57 m) above the meter/regulator assembly	3 ft (91 cm) within a height of 15 ft (4.6 m)*
I	Clearance to service regulator vent outlet	3 ft (91 cm)	3 ft (91 cm)*
J	Clearance to nonmechanical air supply inlet to building or the combustion air inlet to any other appliance	36 in (91 cm)	12 in (30 cm)
K	Clearance to a mechanical air supply inlet	6 ft (1.83 m)	3 ft (91 cm) above if within 10 ft (3 m) horizontally
L	Clearance above paved sidewalk or paved driveway located on public property	7 ft (2.13 m) [†]	7 ft (2.13 m) [†]
M	Clearance under veranda, porch deck, or balcony	12 in (30 cm) [‡]	12 in (30 cm) - open on 3 sides*

¹ In accordance with the current CSA B149.1 Natural Gas and Propane Installation Code

² In accordance with the current ANSI Z223.1/NFPA 54 National Fuel Gas Code

³ If locally adopted installation codes specify clearances different than those illustrated, then the most stringent clearance shall prevail.

⁴ Soffit with 12" depth requires a minimum of 12" vertical clearance from the termination (36" soffit requires a minimum of 36" vertical clearance).

⁵ In the areas where corrosion and discoloration of building materials can occur, a minimum clearance of 12" shall apply.

[†] A vent shall not terminate directly above a sidewalk or paved driveway that is located between two single family dwellings and serves both dwellings.

[‡] Permitted only if veranda, porch, deck, or balcony is fully open on a minimum of two sides beneath the floor.

* Suggested clearances by the manufacturer. If the clearances required by local codes are different from those from the table above, the greater clearance should apply.

Non-Direct Venting (Single Pipe)

If, at any time, the installation location could experience negative pressure, there is a possibility of back drafting cold air through the boiler's heat exchanger. This situation could lead to the freezing of the heat exchanger and malfunction of the boiler.

However, building codes in most jurisdictions disallow negative pressures in residences. In a home with a well-balanced air supply, the heat exchanger should not be in danger of freezing. Because the cause of back drafting is not considered a manufacturing problem, any freezing damage which occurs from back drafting will not be covered by the Navien warranty. If there is any question about the possibility of back drafting in the installation location, use a direct venting system for the boiler.

When using non-direct venting, maintain non-direct vent clearances shown on page 65 as required by **ANSI Z21.10.3 and the National Fuel Gas Code, ANSI Z223.1/NFPA 54, and CAN/CSA B149.1 Natural Gas And Propane Installation Code.**

To use non-direct venting for the boiler:

1. Insert the termination end cap into the intake air duct.

Note Do not glue the end cap to allow for easy removal and cleaning of the cap.

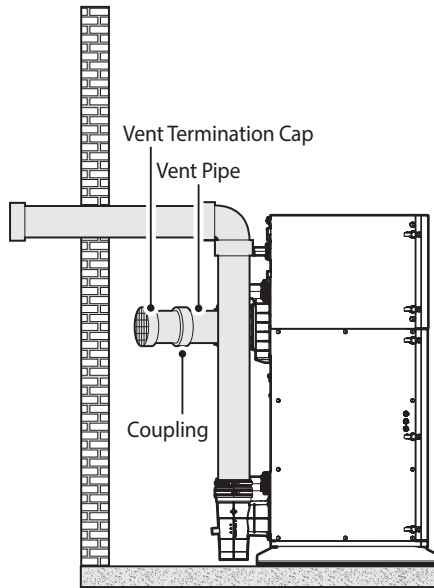

2. Provide two openings to allow for circulation of combustion air as specified by ANSI Z223.1/NFPA 54 or check local codes for the proper combustion air requirements in your region.

	NFB700-500C	NFB700-600C	NFB700-800C	NFB700-1000C
Maximum Input(BTU/H)	499,000	599,000	799,000	999,000
Outside air from 2 openings directly from outdoors	A minimum free area of 1 in ² per 4,000 BTU/H			
	125 in ²	150 in ²	200 in ²	250 in ²
Outside air from 2 ducts directly from outdoors	A minimum free area of 1 in ² per 2,000 BTU/H			
	250 in ²	300 in ²	400 in ²	500 in ²
Inside air from 2 ducts delivered from interior space	A minimum free area of 1 in ² per 1,000 BTU/H			
	499 in ²	599 in ²	799 in ²	999 in ²
Outside air from 1 openings directly from outdoors	A minimum free area of in ² per 3,000 BTU/H			
	166 in ²	200 in ²	266 in ²	333 in ²

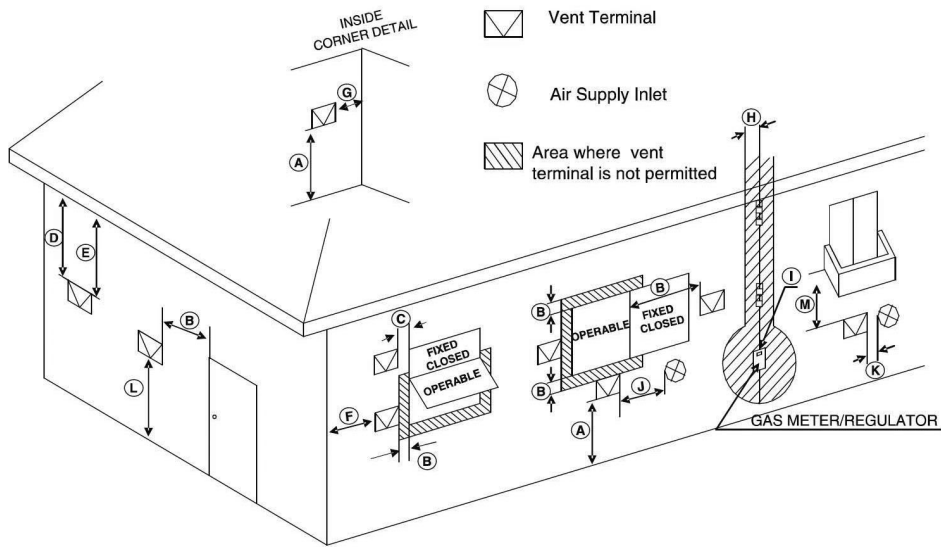

Ref	Description	Canadian Non-Direct Vent Installations ¹	US Non-Direct Vent Installations ²
A	Clearance above grade, veranda, porch, deck, or balcony	12 in (30 cm)	12 in (30 cm)
B	Clearance to window or door that may be opened	36 in (91 cm)	48 in (120 cm) below or to side of opening; 12 in (30 cm) above opening
C	Clearance to permanently closed window	0 in (0 cm) ⁵	0 in (0 cm) ⁵
D	Vertical clearance to ventilated soffit located above the terminal within a horizontal distance of 2 feet (61 cm) from the center line of the terminal	Equal or greater than soffit depth ^{4 5}	Equal or greater than soffit depth ^{4 5}
E	Clearance to unventilated soffit	3 ft (91 cm)*	3 ft (91 cm)*
F	Clearance to outside corner	2 ft (61 cm)*	2 ft (61 cm)*
G	Clearance to inside corner	12 in (30 cm)*	12 in (30 cm)*
H	Clearance to each side of center line extended above meter/regulator assembly	36 in (91 cm) within a height of 15 ft (4.57 m) above the meter/regulator assembly	3 ft (91 cm) within a height of 15 ft (4.6 m)*
I	Clearance to service regulator vent outlet	36 in (91 cm)	3 ft (91 cm)*
J	Clearance to non-mechanical air supply inlet to building or the combustion air inlet to any other appliance	36 in (91 cm)	48 in (120 cm) below or to side of opening; 12 in (30 cm) above opening
K	Clearance to a mechanical air supply inlet	6 ft (1.83 m)	36 in (91 cm) above if within 10 ft (3 m) horizontally

Ref	Description	Canadian Non-Direct Vent Installations ¹	US Non-Direct Vent Installations ²
L	Clearance above paved sidewalk or paved driveway located on public property	7 ft (2.13 m) [†]	7 ft (2.13 m) [†]
M	Clearance under veranda, porch deck, or balcony	12 in (30 cm) [‡]	12 in (30 cm) - open on 3 sides*

1 In accordance with the current CSA B149.1 Natural Gas and Propane Installation Code

2 In accordance with the current ANSI Z223.1/NFPA 54 National Fuel Gas Code

3 If locally adopted installation codes specify clearances different than those illustrated, then the most stringent clearance shall prevail.

4 Soffit with 12" depth requires a minimum of 12" vertical clearance from the termination (36" soffit requires a minimum of 36" vertical clearance).

5 In the areas where corrosion and discoloration of building materials can occur, a minimum clearance of 12" shall apply.

† A vent shall not terminate directly above a sidewalk or paved driveway that is located between two single family dwellings and serves both dwellings.

‡ Permitted only if veranda, porch, deck, or balcony is fully open on a minimum of two sides beneath the floor.

* Suggested clearances by the manufacturer. If the clearances required by the local authority or gas supplier are different from those from the table above, the greater clearance should apply.

5.3 Selecting Vent Pipe Materials

Venting requirements differ in the US and Canada. Consult the following chart or the most recent edition of ANSI Z223.1/NFPA 54 or CAN/CGA B149.1, as well as all applicable local codes and regulations when selecting vent pipe materials. Do not use cellular core PVC (ASTM F891), cellular core CPVC, or Radel® (polyphenolsulfone) for the exhaust vent.

WARNING

Carbon Monoxide Hazard

To prevent serious injury or death:

- ONLY use approved venting materials.
- Review the vent pipe installation instructions carefully.

Improper use and installation of vent pipe may cause system to fail and harmful flue products may leak into the living space. The use of unapproved vent materials will also void the warranty and certification of the water heater.

Locale	Recommended Vent Materials
USA	<ul style="list-style-type: none"> • PVC/CPVC Schedule 40 or 80 (Solid Core) • UL1738 approved PVC or CPVC • Approved Polypropylene (PP) • Approved Stainless Steel (SS)
Canada*	<ul style="list-style-type: none"> • Type BH Special Gas Vent Class IIA (PVC) • Type BH Special Gas Vent Class IIB (CPVC) • Type BH Special Gas Vent Class IIC (Polypropylene/Stainless Steel)

* For installation in Canada, field-supplied plastic vent piping must comply with CAN/CGA B149.1 (latest edition) and be certified to the Standard For Type BH Gas Venting Systems, ULC-S636. Components of this listed system must not be interchanged with other vent systems or unlisted pipes or fittings. All plastic components and specified primers and glues of the certified vent system must be from a single system manufacturer and must not be intermixed with another system manufacturer's parts.

The supplied vent connector is certified as part of the boiler.

The vent system shall be installed in accordance with the boiler manufacturer and, if applicable, the venting system manufacturer's instructions.

This product is set to use **PVC** as the default vent pipe material. If you require that return water hotter than 140°F (60°C) to circulate back to boiler, the DIP switch must be configured (**Dip Switch 2, switch #8 to ON position**). Otherwise, the boiler will control and maintain the flue and SH temperature below 150°F (65°C) and 140°F (60°C) respectively.

Note

When you set PCB DIP switch 2 #8 to On, ensure that CPVC, polypropylene or stainless steel piping is used for exhaust venting.

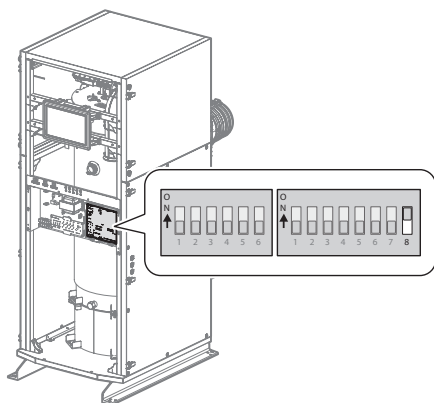

⚠ WARNING

Carbon Monoxide Hazard

To prevent serious injury or death:

- This boiler has a built-in control to limit the exhaust temperature to 149°F (65°C). As a result, the boiler can be vented with Schedule 40 PVC.
- In high temperature applications, the exhaust temperature can exceed 149°F (65°C). In that case, you must use Schedule 40/80 CPVC or Approved Polypropylene/Stainless Steel in the USA or Type BH Special Gas Vent Class IIB (CPVC) or Class IIC (Polypropylene/SS) that conforms to ULC-S636 in Canada.
- When using 4 in (500C/600C) or 6 in (800C/1000C). vent, if the exhaust temperature exceeds 149°F (65°C), CPVC pipe (field supplied) must be used for the first 3 feet of equivalent pipe length. For systems using 6 in (500C/600C) or 8 in (800C/1000C). vent, the first 5 in. of length must be CPVC pipe.

Note

- Only the vent pipe models listed above are approved for use with this appliance.
- Proper appliance adapters must be used when using polypropylene or SS vent pipe.
- Refer to the vent manufacturer's instructions for detailed installation procedures and guidelines.
- Do not use Schedule 40 or 80 polypropylene pipe used for water or waste systems within the vent run.

The following **polypropylene** vent components are approved for use with this appliance:

Duravent PolyPro® SW (Rigid)

(Certified to ULCS636)

- 4PPS-xxx (4")
- 6PPS-xxx(6")
- 4PPS-ADL (4" Appliance Adapter)

Duravent PolyPro® (Flexible)

(Certified to ULCS636)

- 4PPS-FLEXxx (4")
- 4PPS-FAM (4" Rigid-to-Flex Male Adapter)

Centrotherm Innoflue® (Rigid)

(Certified to UL1738 and ULCS636)

- ISxx04xx (4")
- ISxx06xx (6")
- ISAAL0404 (4" Appliance Adapter)
- ISAAL0606 (6" Appliance Adapter)

Z-Flex Z-DENS SW (Rigid)

(Certified to UL1738 and ULCS636)

- 2ZD_ (4")
- 2ZD_ (6")
- 2ZDCPVCG4 (4" Appliance Adapter)
- 2ZDCPVCG6 (6" Appliance Adapter)

The following **stainless steel** vent components are approved for use with this appliance:

Duravent FasNSeal® (Rigid)

(Certified to UL1738 and ULCS636)

- FSA-4PVC-4FNS (4" PVC to FasNSeal Appliance Adapter)
- FSA-6PVC-6FNS (6" PVC to FasNSeal Appliance Adapter)
- F5xxxx04 (4")
- F5xxxx06 (6")

Heat Fab Saf-T Vent® EZ Seal

9401PVC (4" PVC/CPVC Outlet Boiler Adapter)

9601PVC (6" PVC/CPVC Outlet Boiler Adapter)

94xx (4")

96xx (6")

Note

- Only the vent pipe models listed above are approved for use with this appliance.
- Proper appliance adapters must be used when using polypropylene or SS vent pipe.
- Refer to the vent manufacturer’s instructions for detailed installation procedures and guidelines.
- Do not use Schedule 40 or 80 polypropylene pipe used for water or waste systems within the vent run.

5.4 Measuring Vent Length

The maximum vent lengths for each model of the NFB 700 boilers are shown in the table below. The intake duct length may be identical to the exhaust duct length. Maximum vent lengths reduce according to the number of elbows used, as shown in the following table:

Model	Vent Size	Maximum Length	Maximum # of Elbows	Equivalent Length
NFB700-500C	4 in	150 ft (45 m)	8	Reduce the maximum vent length accordingly for each elbow used: <ul style="list-style-type: none"> • Each 90° elbow equates to 5 linear feet of vent • Each 45° elbow equates to 3 linear feet of vent
NFB700-600C				
NFB700-800C	6 in			
NFB700-1000C				

Note

- The maximum length does not include any elbows.
- The use of a PVC or polypropylene termination kit counts as 5 linear feet (1.5 m) of vent.
- The use of a tee counts for the same equivalent length as a 90° elbow for the vent size.
- The maximum vent lengths at high altitudes are the same as shown in the table above.

5.5 Terminating the Vent

Before installing the boiler, determine what type of vent termination is appropriate for the installation location and materials. The subsections that follow describe some typical venting configurations, but do not include all possible options.

The following **PVC** vent terminations are approved for use with this appliance:

- **PVC** Concentric Vent Kit (Sch 40 - UL1738/ULCS636):
 - 4 in Vent Kit
 - 6 in Vent Kit
- **IPEX** Low Profile Termination Kit (Certified to ULCS636)
 - 4 in Low Profile Vent Kit #196986

The following **polypropylene** vent terminations are approved for use:

- **Duravent PolyPro** Horizontal Concentric Termination Kit (Certified to ULCS636)
 - 4 in x 6 in Concentric Vent Kit #4PPS-HKC
- **Centrotherm Innoflue** Low Profile Termination Kit (Certified to UL1738 and ULCS636)
 - 4 in Vent Kit #ISLPT0404
- **Centrotherm Innoflue** Concentric Vent Kit (Certified to UL1738 and ULCS636)
 - 4 in Vent Kit #ICWT462
- **Hart & Cooley Polyflue** Horizontal Termination Kit (Certified to ULCS636)
 - 4 in Vent Kit #4PF-HCT

The following **polypropylene** vent components are approved for use as terminations:

Duravent PolyPro® (Certified to ULCS636)

4PPS-E90L (4" 90° Elbow)
6PPS-E90L (6" 90° Elbow)
4PPS-E45L (4" 45° Elbow)
6PPS-E45L (6" 45° Elbow)
4PPS-TL (4" Tee)
6PPS-TL (6" Tee)
4PPS-BG (4" Birdscreen)
6PPS-BG (6" Birdscreen)

Centrotherm Innoflue® (Certified to UL1738 and ULCS636)

ISEL0487 (4" 87° Elbow)
ISEL0687 (6" 87° Elbow)
ISEL0445 (4" 45° Elbow)
ISEL0645 (6" 45° Elbow)
IST04 (4" Tee)
IST06 (6" Tee)
IASPP04 (4" Birdscreen)
IASPP06 (6" Birdscreen)

Hart & Cooley Polyflue™ (Certified to ULCS636)

4PF-90 (4" 90° Elbow)
4PF-45 (4" 45° Elbow)
4PF-T (4" Tee)
4PF-HVST (4" Birdscreen)

- **Z-Flex Z DENS** Horizontal Termination Kit (Certified to UL1738 and ULCS636)
 - 2ZDE487 (4" 90° Elbow)
 - 2ZDE687 (6" 90° Elbow)
 - 2ZDE445 (4" 45° Elbow)
 - 2ZDE645 (6" 45° Elbow)
 - 2ZDTT4 (4" Tee)
 - 2ZDTT6 (6" Tee)
 - 2ZDES4 (4" Birdscreen)
 - 2ZDES6 (6" Birdscreen)

The following **stainless steel** (AL29-4C) vent components are approved for use as terminations:

Duravent FasNSeal® (Certified to UL1738 and ULCS636)

FSELB9004 (4" 90° Elbow)
FSELB9006 (6" 90° Elbow)
FSELB8804 (4" 88° Elbow)
FSELB8806 (6" 88° Elbow)
FSELB4504 (4" 45° Elbow)
FSELB4506 (6" 45° Elbow)
FST4 (4" Tee)
FST6 (6" Tee)
FSBS4 (4" Birdscreen)
FSBS6 (6" Birdscreen)

Heat Fab Saf-T Vent® **EZ Seal** (Certified to UL1738 and ULCS636)

9414(LR) or 9414TERM (4" 90° Elbow)
9614(LR) or 9614TERM (6" 90° Elbow)
9411 (4" 45° Elbow)
9611 (6" 45° Elbow)
9490TEE (4" Tee)
9690TEE (6" Tee)
9492 (4" Birdscreen)
9692 (6" Birdscreen)

Note

- Only the termination models listed above are approved for use with this appliance.
- Only terminations of the same manufacturer as the vent system must be used.
- Refer to the vent manufacturer's instructions for detailed installation procedures and guidelines.

Indoor Boiler Installation Venting

Examples

⚠ DANGER

Fire and Explosion Hazard

To prevent death, serious injury or property damage:

- ALWAYS make sure to follow the provided clearance requirements.
- Failure to do so may result in circulating exhaust gas and cause dangerous operation of the boiler.

The following are some possible indoor venting options:

- Multiple Vent / Air Terminations

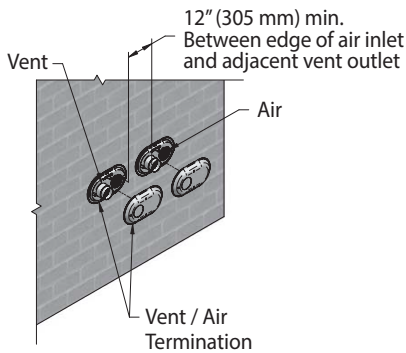

- Multiple Vent

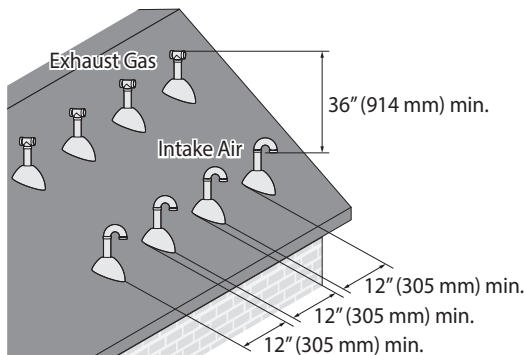

- Two-Pipe Sidewall Venting

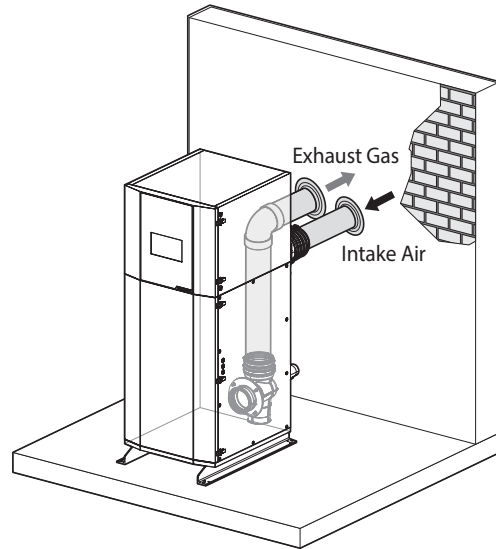

Interior View

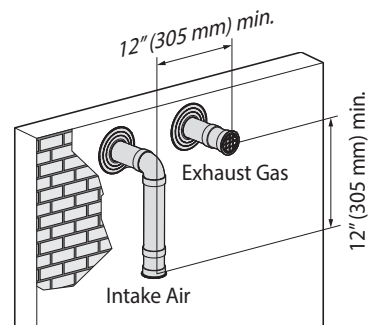

Exterior View

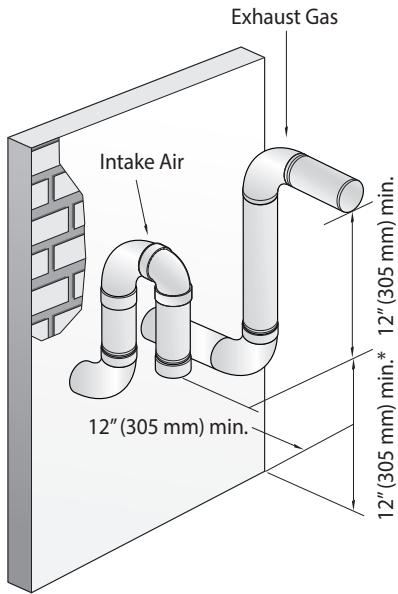

Two-Pipe Snorkel Sidewall Venting

* Clearance above highest anticipated snow level or grade, or as required by local codes, whichever is greater.

- Two-pipe Vertical Venting - Intake and exhaust pipes do not have to terminate in the same area.

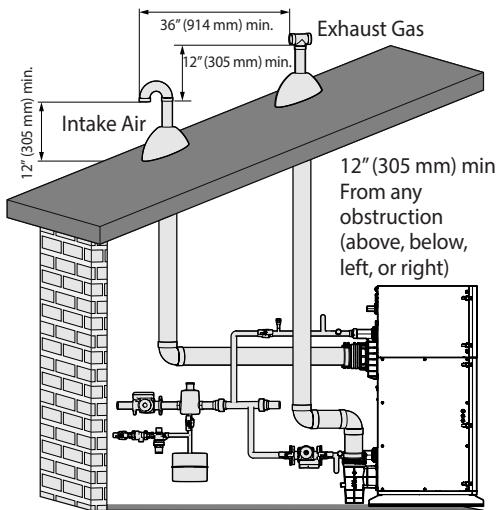

- Non-Concentric Vertical/Sidewall Venting - Air is drawn from a different location that is at least 12 in (305 mm) away from the exhaust termination. The exhaust termination can be located either on the sidewall or roof. Try to minimize the length of the intake air pipe when installing the vent.

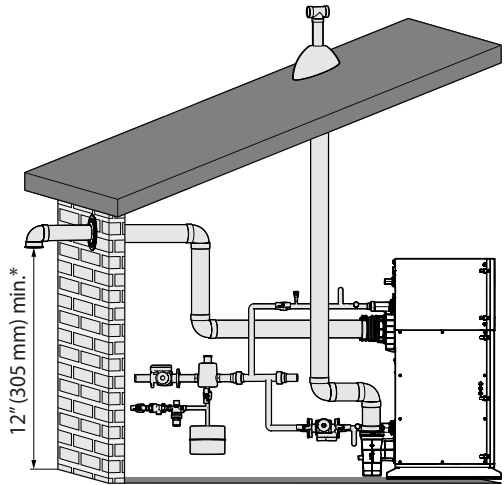

Note

A tee is recommended for vertical termination to prevent excessive water from flowing back into the condensate drain. If a tee is not installed, additional seasonal maintenance and monitoring of the drain may be required.

- Concentric Sidewall Venting

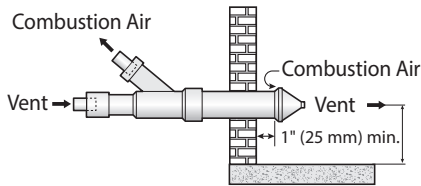

Maintain 12" (305 mm) min. clearance above highest anticipated snow level or grade, whichever is greater.

- Concentric Vertical Venting

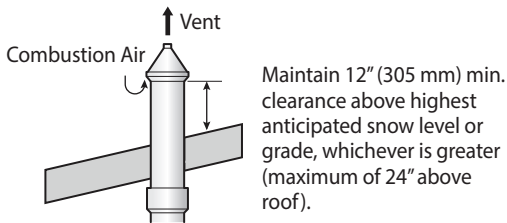

Maintain 12" (305 mm) min. clearance above highest anticipated snow level or grade, whichever is greater (maximum of 24" above roof).

Note For cascade applications, the required horizontal clearance between terminations is 12" for both sidewall and vertical venting installations.

CAUTION



Do not vertically stack concentric terminations on sidewalls. The circulation of exhaust gases will cause improper operation of the boiler.

Indoor Boiler Installation Venting Examples (Continued)

- Low Profile Two-Pipe Sidewall Venting*

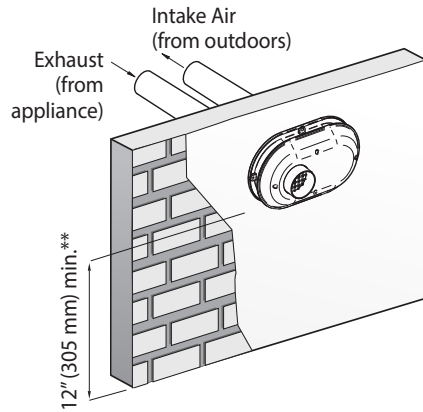

Exterior View

* IPEX and Centrotherm Low Profile terminations only

** Clearance above highest anticipated snow level or grade, or as required by local codes, whichever is greater

Note Only the following orientations are allowed for twin pipe terminations.

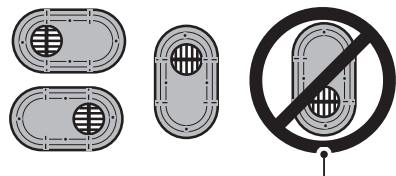

NEVER install in this orientation with the exhaust located nearest to the ground.

5.6 Replacing the Air Filter

The NFB 700 boiler is equipped with an air filter to prevent dust and foreign substances from accumulating inside the boiler, and the air filter should be inspected at least once a month and replaced if needed. Follow the instructions below to remove and replace the air filter.

1. Remove the 8 screws from the air filter located on the intake air connection.

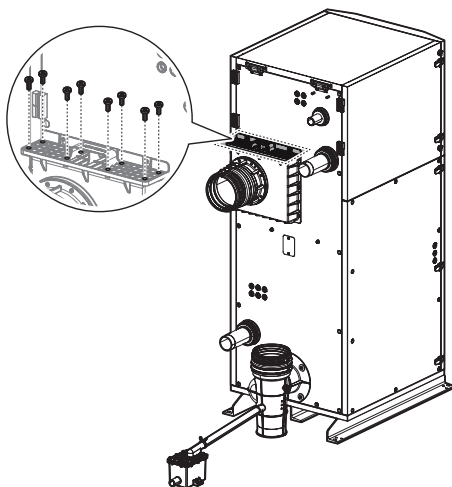

2. Lift the air filter upwards to remove it.

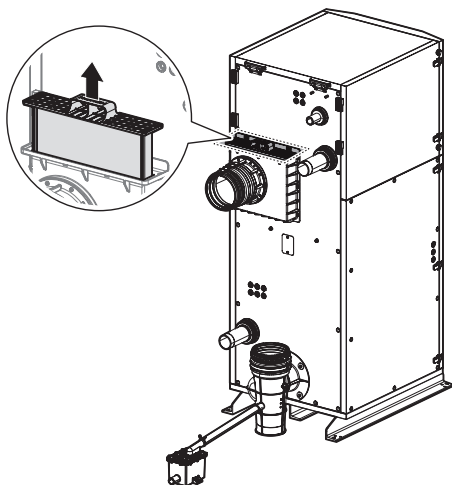

3. After replacing it with a new air filter, tighten the 8 screws to secure it.

Note

One Replacement filter is included. Additional filters can be ordered through authorized Navien distributors.

CAUTION

- If the air filter is not replaced, it may result in poor performance of the boiler.
- If the air filter is fully blocked with dust and debris, an error code may occur due to intake blockage being detected in the boiler.

6. Setting the DIP Switches

⚠ DANGER

- Do not remove the front cover unless the power to the boiler is turned off or disconnected. Failure to do so may result in electric shock.
- Configure only the DIP switches that require adjustment according to the instructions in this manual. Do not adjust any other DIP switches.
- Ensure that the High Altitude setting reflects the actual location of the boiler. If not, it may cause personal injury or malfunction of the boiler.

The boiler has 2 sets of DIP switches on the main circuit board (PCB). DIP switches are used to control the functionality of the boiler. Set the DIP switches appropriately, based on the installation environment.

6.1 DIP Switch 1 (6 switch unit)

The DIP SW 1 on the circuit board configures the operation status.

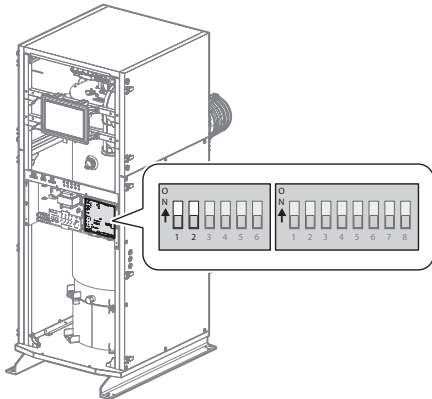

Switch	Function	Setting	
1 & 2	Operation Status	Normal Operation	1-OFF, 2-OFF
		2-stage MAX	1-ON, 2-OFF
		1-stage MIN	1-OFF, 2-ON
		1-stage MAX	1-ON, 2-ON

Note

The remaining 4 switches of DIP SW 1 are factory set, and should not be adjusted. Refer to the Service Manual or contact Technical Support at 1-800-519-8794.

6.2 Dip Switch 2 (8 switch unit)

The DIP SW 2 on the circuit board configures the gas type, temperature control modes, country, and enables or disables the space heating thermostat.

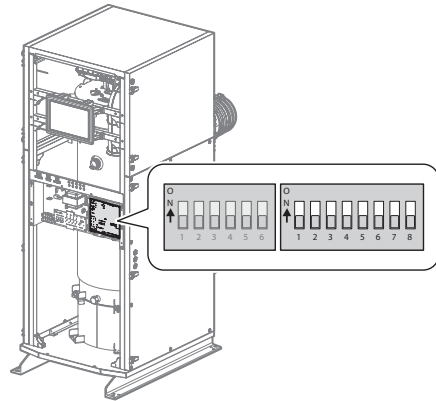

Switch	Function	Setting		Comment	
1	Gas Type	Natural Gas	1-OFF	Refer to Table 1 in "11.1 Gas & High Altitude Conversion" on page 120.	
		Propane Gas	1-ON		
2 & 3	High Altitude*	0-1,999 ft (0-609 m)	2-OFF, 3-OFF		
		2,000-5,399 ft (610-1,645 m)	2-ON, 3-OFF		
		5,400-7,699 ft (1,646-2,346 m)	2-OFF, 3-ON		
		7,700-10,100 ft (2,347-3,078 m)	2-ON, 3-ON		
4	Reserved	-	-		-
5 & 6	Country	US/Canada	5-OFF, 6-OFF		-
7	Space Heating Thermostat	Used	7-OFF	-	
		Unused	7-ON	-	
8	Exhaust Temperature Control	Used	8-OFF	-	
		Unused	8-ON	-	

* Please confirm the installation elevation by using the provided QR code to access the following website (<https://www.navieninc.com/elevation>) and entering the proper zip/postal code.

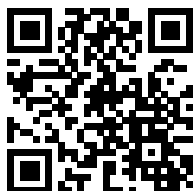

Note

- When PCB DIP switch 2 #8 is set to On, ensure that CPVC, polypropylene, or stainless steel is used for exhaust venting.
- This unit may be installed at elevations up to 10,100 ft (3,078 m) for use with natural gas and propane. A derate of 2.2% is required at this elevation. To use the unit at a specific altitude, the DIP switches should be set as described above.
- For NG, if you install the unit at or above 5,400 ft (1,646 m), it is required to change the Gas Orifice for high altitude. Be careful not to confuse it with the Propane Gas Orifice. Refer to "11.1 Gas & High Altitude Conversion" on page 120 for details.
- Common vent installations for use with natural gas and propane are only approved for up to 4,500 ft.

⚠ DANGER

- ALWAYS install the High Altitude Conversion Kit if needed based on the elevation of the installation location.
- For use with propane gas, the Propane Gas & High Altitude Conversion Kit MUST be used for elevations **up to 10,100 ft.**
- The Natural Gas High Altitude Conversion Kit is located inside the boiler cabinet. You will need to remove the front cover to access the Natural Gas High Altitude Conversion Kit.
- Refer to the Natural Gas High Altitude Conversion Guide and verify the orifice is appropriate for the boiler. Replace the orifice following the Natural Gas High Altitude Conversion Guide instructions if required.

7. Connecting the Power Supply

⚠ WARNING

Electric Shock Hazard

To prevent serious injury or death:

- ALWAYS follow all applicable electrical codes of the local authority having jurisdiction.
- In the absence of such requirements, follow the latest edition of the National Electrical Code (NFPA 70) in the USA or the latest edition of CSA C22.1 Canadian Electrical Code Part 1 in Canada.
- ONLY licensed professionals should connect the power supply.

When connecting the power supply, follow these guidelines:

- Do not connect the electric supply until all piping and gas piping is complete and the boiler has been filled with water.
- Make sure to connect the boiler to a 110-120 VAC power supply at 60 Hz using a dedicated circuit. Do not connect the boiler to a 220-240 V AC power supply. Doing so will damage the boiler and void the warranty.
- Connect the building wires 'L', 'N', 'G' to the terminal block according to the printed specifications on the boiler PCB. The 'G' terminal should be connected to the building ground.

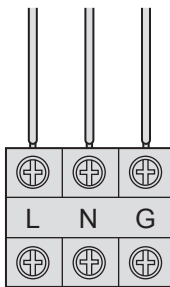

Note

The rated current of the wires is 12 A.

- When connecting an external pump to the boiler, connect it to the external pump terminal of the boiler PCB. Connect the wires referring to the following table. The pump ground should be connected to the boiler and the building ground. For details, refer to the "11.2 Wiring Diagram" on page 128.

1. Boiler Pump	N-phase	<->	1. Building wire	N-phase
2. Building wire	L_IN-phase	<->	2. Boiler PCB	L_IN-phase
3. Boiler Pump	L_IN-phase	<->	3. Boiler PCB	L_OUT-phase

Note

The rated load of the provided dry contacts is designed to be 5 A/120 V for each zone pump output, and 10 A/120 V for the boiler pump.

- If there is a power failure in cold weather areas, the freeze prevention system in the boiler will not operate and may result in the heat exchanger freezing. In cold areas where power failures are common, you must completely drain the boiler to prevent damage if power cuts last for extended periods. Damage caused by freezing is not covered under warranty.

Note

If draining system water contains glycol, recovery and proper disposal may be required based on local codes.

⚠ CAUTION

Label all wires before disconnecting them when you work on the controls. Wiring errors can cause improper and dangerous operation. Verify proper operation after servicing.

If you are not using your boiler for a long period of time:

1. Completely drain the water out of the boiler.
2. Disconnect the power supply to the boiler.
This prevents your boiler from freezing and being damaged.

 **WARNING**

Electric Shock Hazard

To prevent serious injury or death:

- ALWAYS label all wires before disconnecting them when you work on the controls.
- Wiring errors can cause improper and dangerous operation.
- ALWAYS verify proper operation after servicing.

8. Installing a Cascade System

When installing a cascade system, carefully consider the design of the system and the features of the installation location. Follow all local codes and regulations, as well as all guidelines for installing the boiler. The following sections describe additional considerations that are specific to installing cascade systems. Read them carefully before designing or installing the system.

8.1 Connecting Water Supplies

Several options are available for configuring a cascade system of boilers. The options shown here are only examples. The setup you choose will vary based on the installation location, local building codes, and other factors. Follow all applicable regulations when installing a cascade system.

You can connect up to 8 boilers to meet high-volume heating demands. Some possible connection options include the following:

- Example of a Basic Cascade System Application

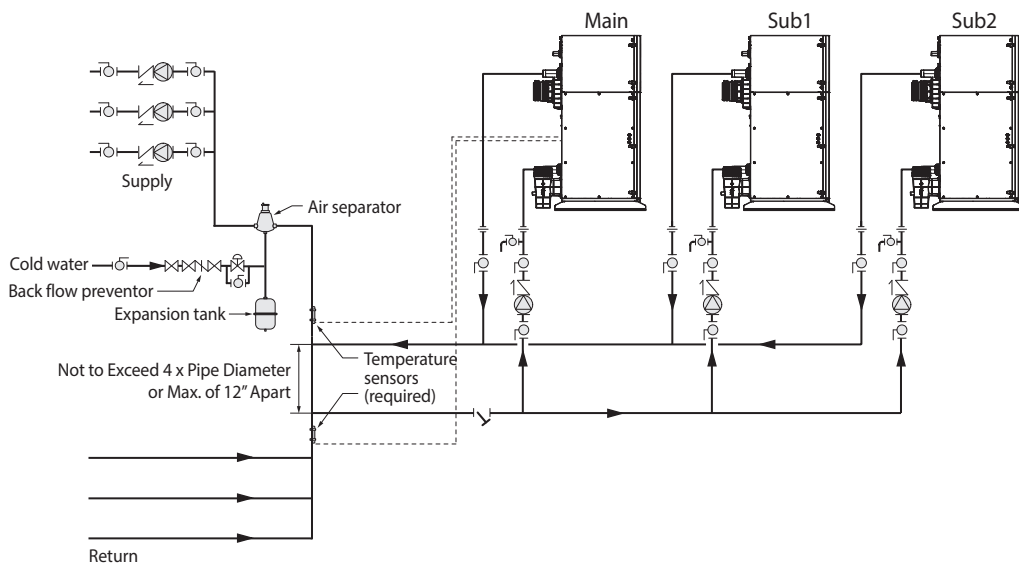

[NFB700]

Note

- System application drawings are intended to explain the system piping concept only.
- Install a filter in the system return to remove foreign objects from the system. Foreign objects inside the system may result in abnormal system operation.
- Refer to “3.3 Filling the System” on page 32 for make-up water connections and refer to the requirements of your local codes to ensure compliance.
- Use pumps with integral check valves or install check valves at the pump outlets.
- Navien universal temperature sensors (#GXXX001769) must be installed for cascade system operation.
- Adjust the settings at the main unit as the cascade system uses only the main unit settings. Changes made to the sub units are ignored.
- Refer to “10.7.5 Configuring a Cascade System” on page 106 to make adjustments to the boiler staging settings. By default, boilers will be added to the system when the input capacity exceeds 60%, and removed when the input capacity falls below 30%.

• System Application #1- Cascade System with Closely Spaced Tees

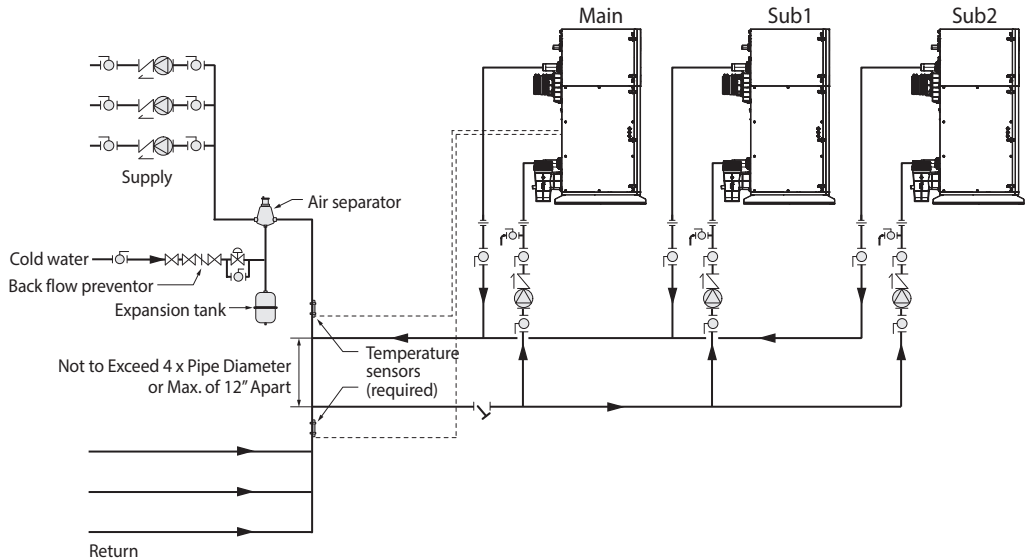

Note

- Connect the "SH Demand (SH T/T or Zone controller)" to the main unit.
- Connect the universal temperature sensors to SUPPLY and RETURN terminals of the CNST1/CNST2 terminal strip on the main unit PCB.
- Connect the outdoor sensor (optional) to the main unit.
- Multi-zone temperature function is also available for this application.

• System Application #2- Cascade System with Hydraulic Separator

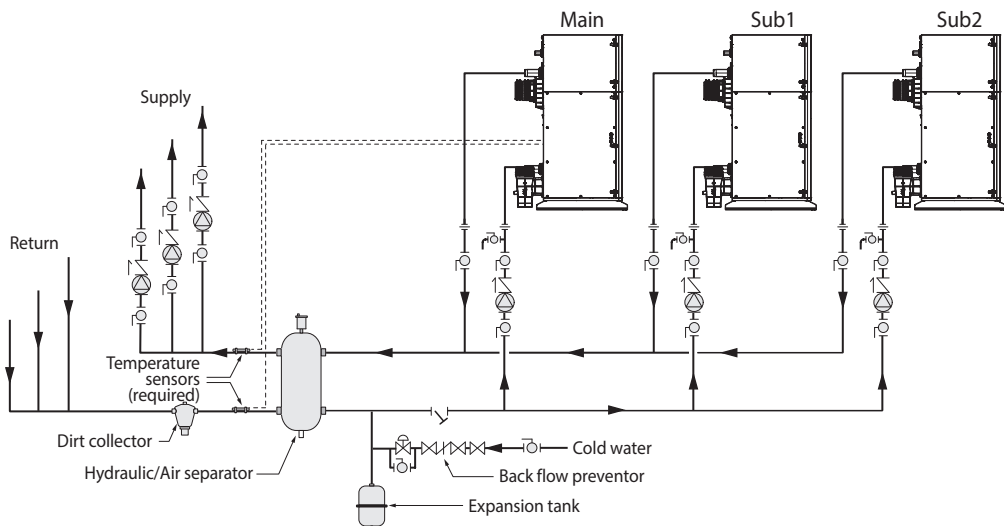

Note

- Connect the "SH Demand (SH T/T or Zone controller)" to the main unit.
- Connect the universal temperature sensors to SUPPLY and RETURN terminals of the CNST1/CNST2 terminal strip on the main unit PCB.
- Connect the outdoor sensor (optional) to the main unit.

• System Application #3 - Cascade System with Zone Pump Control

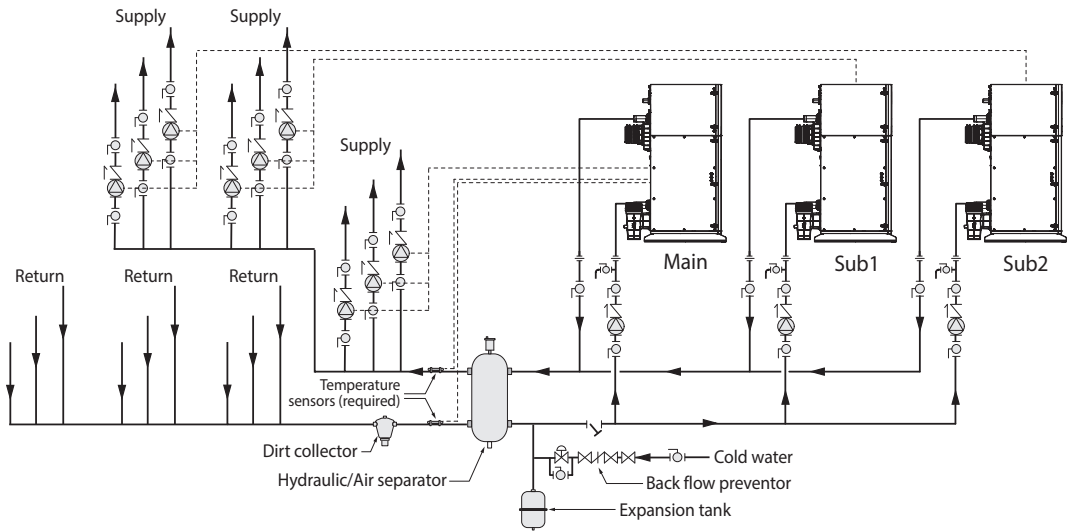

Note

- Both the main unit and sub units use zone pumps for this application. To enable this feature, tap the Control button  > **SH Control** and set the Zone Setting to "OFF"
- Connect the zone pump to the main unit or subunit, and connect the "SH Demand (SHT/T)" to the zone that the pump is connected to.
- Connect the supply/return sensors to SUPPLY and RETURN terminals of the CNST1/CNST2 terminal strip on the main unit PCB.
- Connect the outdoor sensor (optional) to the main unit.
- Multi-zone temperature function is not available for this application.

• System Application #4 - Cascade System with DHW Indirect Tank and Closely Spaced Tees

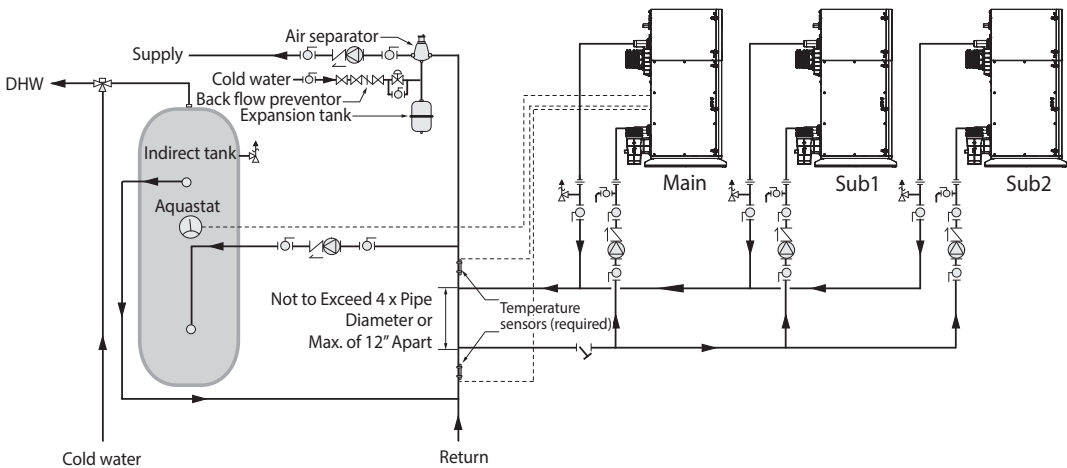

Note

- Connect the aquastat on the DHW indirect tank to the main unit.
- Connect the DHW pump to the main unit.

- System Application #5 - Cascade System with DHW Indirect Tank and Hydraulic Separator

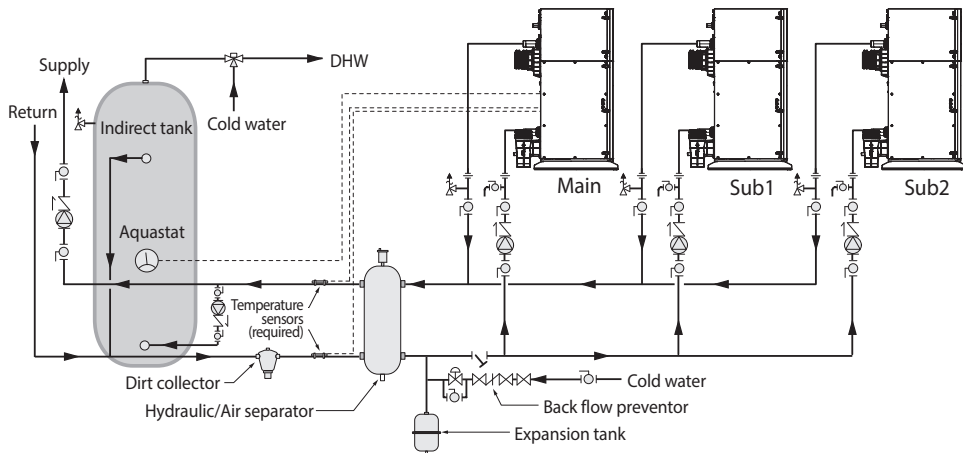

Note

- Connect the aquastat on the DHW indirect tank to the main unit.
- Connect the DHW pump to the main unit.

- System Application #6- Cascade System with DHW Indirect Tank and Tank and Closely Spaced Tees (for Low DHW Demand)

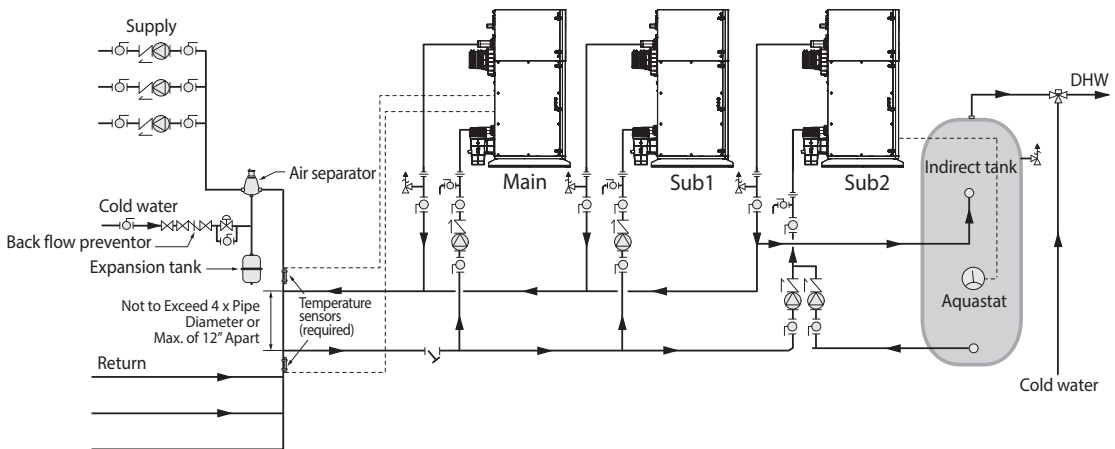

Note

- In this configuration, space heating and DHW can operate simultaneously.
- The aquastat on the DHW indirect tank must be connected to a sub unit.
- If a dedicated sub unit is used, the input capacity requirement of the indirect tank shall not exceed the capacity of the single boiler.
- Connect the DHW pump to the sub unit.

- System Application #7 - Cascade System with DHW Indirect Tank and Hydraulic Separator (for Low DHW Demand)

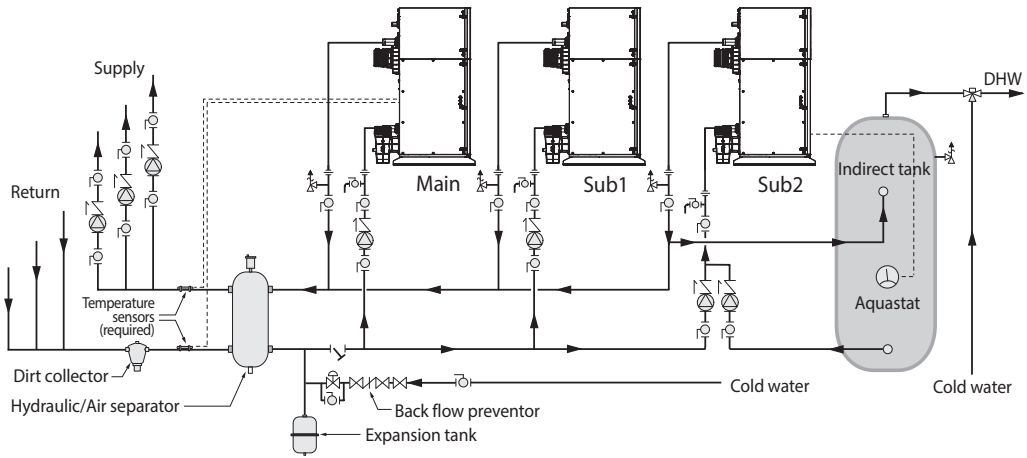

Note

- In this configuration, space heating and DHW can operate simultaneously.
- The aquastat on the DHW indirect tank must be connected to a sub unit.
- If a dedicated sub unit is used, the input capacity requirement of the indirect tank shall not exceed the capacity of the single boiler.
- Connect the DHW pump to the sub unit.

8.1.1 Piping Sizes and Considerations

When configuring a cascade system, consider the following pipe diameters and flow rates. Note that flow rates above 4 ft/s may cause pipe erosion or velocity noise. These specifications may vary depending on installation conditions.

NFB700-500C/600C

Qty	Flow Rate (GPM) @ 20 °F ΔT	Recommended Boiler Pipe Sizes (2-4 ft/s)
2	116	3-1/2"
3	174	4"
4	232	5"
5	290	6"
6	348	6"
7	406	8"
8	464	8"

NFB700-800C/1000C

Qty	Flow Rate (GPM) @ 20 °F ΔT	Recommended Boiler Pipe Sizes (2-4 ft/s)
2	190	4"
3	266	5"
4	380	6"
5	456	8"
6	570	8"
7	640	8"
8	736	10"

8.2 Connecting the Communication Cables

Up to 32 boilers can be connected with Navien Ready-Link communication cables. Select one of the boilers in the cascade system as the main boiler, and then connect the other boilers to it as sub boilers. Before making any connections, ensure that the power is turned off to all boilers.

Connect the Ready-Link cables to the CNK1 terminal strip on the PCB:

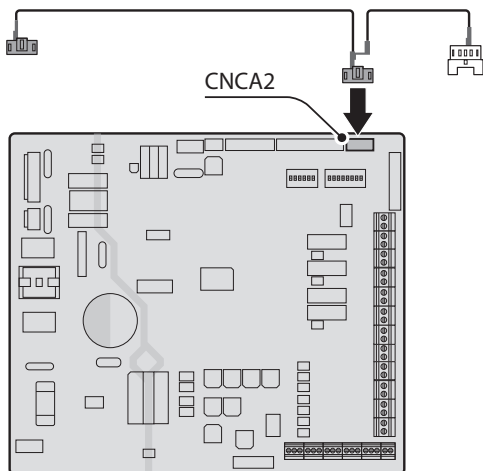

8.2.1 Configuring the Communication Settings

After connecting the Ready-Link communication cables, restore power to the boiler and turn on all boilers using the Power button.

To configure the communication settings, refer to “10.7.5 Configuring a Cascade System” on page 106.

To connect more than 2 boilers, additional Ready-Link cables are required. The total number of cables needed will be 1 less than the total number of boilers.

9. Installation Checklist

After installing the boiler, review the following checklist. You should be able to answer “Yes” to all of the items in the checklist. If not, review the appropriate sections to complete the installation. To troubleshoot any operational problems refer to “Troubleshooting” in the User’s Information Manual.

If you have additional questions or need assistance with installation, contact Technical Support at 1-800-519-8794 or 1-949-420-0420, or refer to the technical support section of Navien’s website (www.navieninc.com).

Installing the boiler	Yes	No
Have you maintained the required clearances from building openings and intake air vents?		
Have you minimized the distance between the boiler and major fixtures?		
Have you maintained the proper service and maintenance clearances?		
Is the make-up air supply sufficient for proper operation?		
Is the make-up air supply free from dust, dirt, corrosive elements, and flammable vapors?		
Is the boiler and vent piping clear of combustible materials, including clothing, cleaning materials, and rags?		

Connecting the Gas Supply	Yes	No
Does the gas supply match the type specified on the boiler’s rating plate?		
Is the diameter of the installed gas line larger than the minimum requirement for each boiler model? (The minimum requirement is 1 in for NFB-500C/600C models and 1-1/4 in for NFB-800C/1000C models.)		
Is the gas supply line sufficient in length and diameter to deliver the required BTUs?		
Have you measured the pressure of the gas supply line?		
Is the gas supply pressure within the recommended ranges specified in this manual?		
Is the gas supply line equipped with a manual shut-off valve?		
Have you tested the gas line pressure and all fittings for leaks?		
Has the gas company inspected the installation, if required?		

Connecting the Space Heating Piping	Yes	No
Has the system been filled and purged of air?		
Does the piping incorporate means for air removal (scoop, separator, etc.)?		
Is there an expansion tank installed and set to the proper system pressure?		
If propylene glycol has been used, is it the proper type and is the concentration appropriate?		

Connecting a Pressure Relief Valve	Yes	No
Have you installed an approved pressure relief valve on the boiler?		
Does the rating of the pressure relief valve match or exceed the maximum BTU rating of the boiler?		
Is the pressure relief valve $\frac{3}{4}$ in on the space heating outlet?		
Have you installed the pressure relief valve on the supply pipe?		
Have you installed a discharge drain tube from the pressure relief valve to within 6-12 in (152-305 mm) of the floor?		

Connecting the Condensate Drain	Yes	No
Have you installed a condensate drain line from the boiler to a drain or laundry tub?		

Venting the boiler	Yes	No
Have you vented the boiler with PVC, CPVC, polypropylene, stainless steel, Type BH Special Gas Vent (ULC-S636) for Category IV boilers (Canada), or in accordance with all local codes and the guidelines in this manual?		
Have you ensured that ABS or PVC cellular core pipe has not been used as venting for the boiler?		
Is the vent sloped upward toward the vent termination at a rate of $\frac{1}{4}$ in per foot (2% grade)?		
Are all vent runs properly supported?		
Is the vent termination properly supported?		
Are the air intake and exhaust connections on the flue and vent lines correctly sealed?		
Have you installed vent screen caps on the exhaust and intake pipes?		
Have you checked the venting for leaks?		
Is the vent termination at least 12 in (305 mm) above the exterior grade?		
Have you ensured that sufficient make-up air is available?		
Is the total vent length within the maximum vent length restriction?		

Connecting the Power Supply	Yes	No
Is the supplied voltage 110-120V AC?		
Is the boiler plugged into a properly grounded outlet?		
If you have made a direct power supply connection, have you installed a power switch to facilitate end-user maintenance?		
Have you checked the polarity of the electrical connection?		

PCB DIP switch setting (DIP SW 2, set of 8)	Yes	No
Gas type: Is switch #1 set correctly for Propane (ON) or Natural Gas (OFF)?		
If continuous boiler operation is required, is switch #7 in the up (ON) position?		
If high temperature venting has been installed (CPVC or polypropylene), is switch #8 in the up (ON) position?		

Operating the boiler	Yes	No
Have you given the Installation & Operation Manual and User's Information Manual to the owner for future reference?		
Have you shown the owner how to shut off the gas in case of an emergency?		

10. Operating the Boiler



10.1 Operating the Boiler for the First Time

FOR YOUR SAFETY READ BEFORE OPERATING

WARNING: If you do not follow these instructions exactly, a fire or explosion may result, causing property damage, personal injury or loss of life.

- A. This appliance does not have a pilot. It is equipped with an ignition device which automatically lights the burner. Do NOT try to light the burner by hand.
- B. BEFORE OPERATING, smell all around the appliance area for gas. Be sure to smell next to the floor because some gas is heavier than air and will settle on the floor.
WHAT TO DO IF YOU SMELL GAS
 - Do NOT try to light any appliance.
 - Do NOT touch any electrical switch.
 - Do NOT use any phone in your building.
 - Immediately call your gas supplier from a neighbor's phone. Follow the gas supplier's instructions.
 - If you cannot reach your gas supplier, call the fire department.
- C. Use only your hand to push in or turn the gas control knob. Never use tools. If the knob will not push in or turn by hand, don't try to repair it, call a licensed professional. Force or attempted repair may result in a fire or explosion.
- D. Do not use this appliance if any parts have been under water. Immediately call a licensed professional to inspect the appliance and to replace any part of the control system and any gas control which has been under water.

OPERATING INSTRUCTIONS

1. STOP! Read the safety information above this label.
2. Turn off all electrical power of the appliance.
3. Set the thermostat or other operating control to the lowest setting.
4. This appliance is equipped with an ignition device which automatically lights the burner.
Do NOT try to light the burner by hand.
5. Close the main gas shut off valve. 
6. Wait (5) minutes to clear out any gas. Then smell for gas around the appliance and near the floor.
If you smell gas, STOP! Follow "B" in the safety information above.
If you don't smell gas, go to the next step.
7. Open the main shut off valve. 
8. Turn on the appliance.
9. Set the thermostat or other operation control to desired setting.
10. If the appliance will not operate, follow the instructions "To Turn Off Gas To Appliance" and call your service technician or gas supplier.

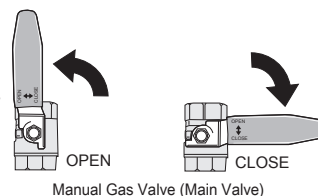

TO TURN OFF GAS TO APPLIANCE

1. Turn off all electric power to the appliance if service is to be performed.
2. Set the thermostat or other operating control to the lowest setting.
3. Close the main gas shut off valve. 

WARNING

To prevent death, serious injury or property damage:

- Ensure that the boiler is filled with water before turning on the boiler for the first time. Turning on a boiler that is not filled will damage the boiler and result in property damage, severe personal injury, or death. Such damage is not covered by warranty.
- At initial fill up and during boiler startup and testing, check system thoroughly for leaks. Repair all leaks before proceeding further.
- Before starting the boiler, use a combustible gas leak detector to check around the outside of the boiler. Remove the front cover and use the detector to check for the presence of gas inside the boiler enclosure. Do not proceed with startup if there is any indication of a gas leak.
- If overheating occurs or the gas supply fails to shut off, do not turn off electrical power to the circulating pump. Turning off the circulation pump may aggravate the problem and increase the chance of boiler damage. Instead, shut off the gas supply to the boiler at the manual gas valve.
- If any part of the appliance has been submerged in water, do not use this appliance and immediately call a qualified service technician. The appliance must be replaced if it has been submerged. Attempting to operate an appliance that has been submerged could create numerous harmful conditions, such as a potential gas leakage causing a fire and/or explosion, or the release of mold, bacteria, or other harmful particulates into the air. Operating a previously submerged appliance could result in property damage, severe personal injury, or death.
- Do not try to light the burner manually. This appliance is equipped with an electronic ignition device which automatically lights the burner.

10.2 Turning the Boiler On or Off

The Start-up Wizard will run the first time the unit is powered on. It must be completed before the boiler can be used.

Follow the procedures below to complete the Start-up Wizard.

1. Connect the boiler to the power supply. When the power is on, the User Settings screen is displayed.



2. Select the language you want to use and set the temperature unit, current date, and time by tapping your selections on the screen.
3. Tap **Next** on the top right of the screen to go to the Gas Type Settings screen.

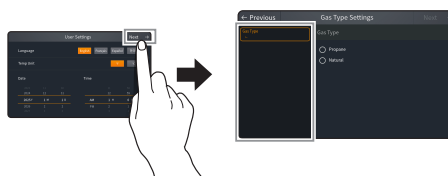

Note

The Next button becomes available only when the selected type matches the PCB DIP switch gas type settings.

4. Tap **Next** on the top right of the screen to go to the Detail Settings screen.

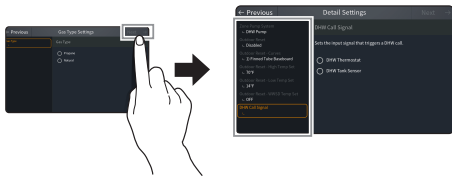

Tap an item to set the detail settings.

Item	Description
Zone Pump System	Select the function of Zone 1 pump (SH zone 1 or DHW).
Outdoor Reset	Enable or disable the outdoor reset function.
Outdoor Reset - Curves	Select the outdoor reset load.
Outdoor Reset - High Temp Set	Set the maximum outdoor reset temperature for outdoor reset control.
Outdoor Reset - Low Temp Set	Set the minimum outdoor reset temperature for outdoor reset control.
Outdoor Reset - WWSD Temp Set	Enable or disable the Warm Weather Shut Down temperature function.
DHW Call Signal	Set the input signal that triggers a DHW call.

5. Tap **Next** on the top right of the screen to complete the settings, and then tap **Yes** to begin the air purge operation for 900 seconds or **No** to skip the operation.



6. Tap **Next** on the top right of the screen to enter the Detail Settings screen.

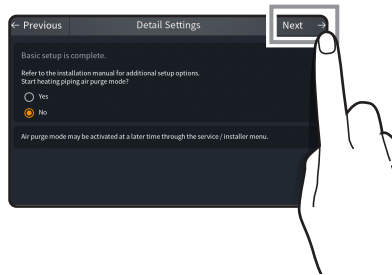

7. Select **Solo** and tap **Next** to enter the Wi-Fi Settings screen, or select **Cascade** and tap **Next** to bypass the Wi-Fi Settings screen.

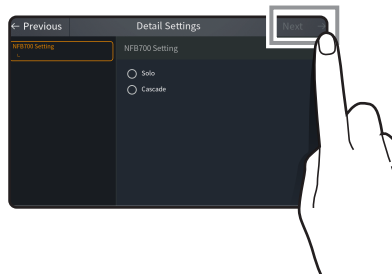

8. Tap **New Register** to generate a QR code for device registration with the Navi-Link app after connecting to Wi-Fi, or tap **Change Wi-Fi** to change the Wi-Fi AP connection.

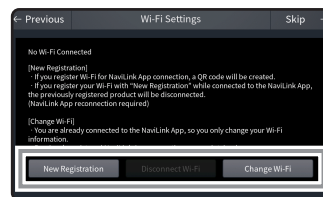

Note

The **Wi-Fi Disconnect** is activated when connected to Wi-Fi and will disconnect when tapped.

- Select the SSID you want to connect to. If there is no SSID, tap the Scan button (🔄).

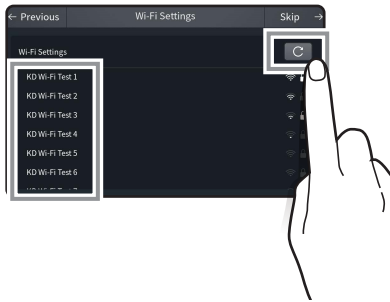

If you do not need a Wi-Fi connection, tap **Skip** on top right of the screen.



- If a password has been set, enter the password with the virtual keyboard shown on the screen and tap **Done**.

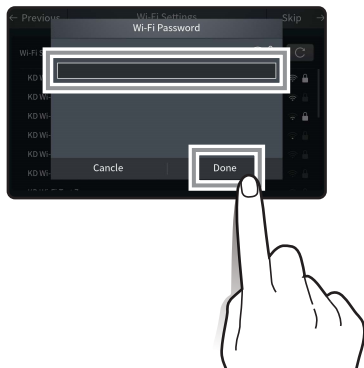

- After connecting to Wi-Fi by tapping the **Register New** on previous step, a QR code will be generated that can be used to register the device in the Navi-Link app.

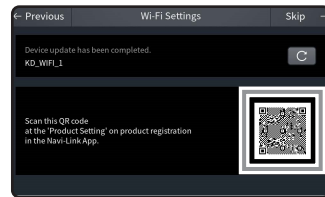

10.2.1 Turning the Space Heating On or Off

To turn the Space Heating on or off, tap **SH ON** on the top left of the screen.





10.2.2 Turning the DHW On or Off

To turn the DHW on or off, tap **DHW ON** on the top right of the screen.



10.3 Adjusting the Temperature

10.3.1 Adjusting the Space Heating Temperature

To adjust the heating temperature on the screen, tap  or  in the SH Set Temp menu or drag the adjustment bar left or right.

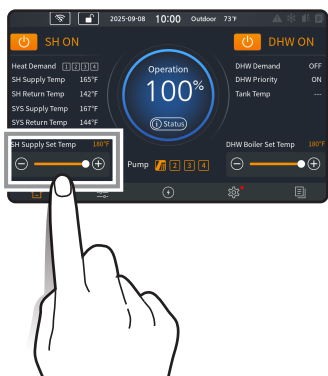

The current temperature setting is displayed in the menu.



Note

- The space heating temperature cannot be adjusted if the boiler is operating as a sub unit in a cascade system. The main unit's set temperature will be displayed on the screen.
- In case of outdoor reset sensor malfunction, the boiler will operate at this set temperature.
- Take note of the original heating temperature in case you want to restore it to the default.
- The default space heating supply water temperature range is 104°F (40°C, Absolute MIN) to 180°F (82°C, Absolute MAX).
- The default space heating return water temperature range is 86°F (30°C, Absolute MIN) to 149°F (65°C, Absolute MAX).
- You can adjust the temperature ranges in the parameter settings menu.

10.3.2 Adjusting the DHW Indirect Supply Temperature

To adjust the water temperature on the screen, tap  or  to select the DHW Indirect Supply temperature in the DHW Set Temp menu or drag the adjustment bar left or right. The current temperature setting is displayed in the menu.



Note

- Take note of the original DHW indirect supply temperature in case you want to restore it to the default.
- When using the DHW tank temperature sensor, the default range is 86°F (30°C) to 162°F (72°C, [Absolute Max - 18°F (10°C)]).
- When using the Aquastat, the default range is 104°F (40°C, Absolute Min.) to 180°F (82°C, Absolute Max.).
- You can adjust the temperature ranges in the parameter settings menu.

10.4 About the Operating Status Information

The following table provides detailed information for the operating status displays that appear when using the boiler.

Item	Operating Status Displays	Description
Standby		The boiler is on standby for a new operation.
Start Up		The boiler operation has started. (The pre-purge is being performed by operating the fan and the pump is operating.)
Operation		The flame has been detected. The heat is being controlled via ratio control.
Post Purge		Combustion has stopped. The post-purge is being performed by operating the fan.
Set Point Match		The set temperature has been reached and combustion has stopped. The boiler is on standby for a new operation until reignition is required.
ERROR		Combustion has stopped due to an error. To view detailed error information, tap the operating status display.
Alarm		An alarm has occurred. Boiler operation may be restricted. To view detailed alarm information, tap the operating status display.

10.5 Resetting the Boiler

If an error message appears during boiler operation, tap **Reset** to restart the boiler and resolve the issue.

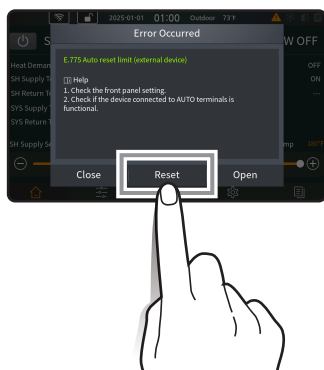

If resetting the boiler does not solve the problem, refer to the “Troubleshooting” section in the User’s Information Manual or contact Technical Support at 1-800-519-8794.

10.6 Accessing Basic Menu Items

In the Control menu, you can view the boiler’s operating conditions; configure the space heating and DHW temperatures.

Tap the Control button () to enter the Control menu.

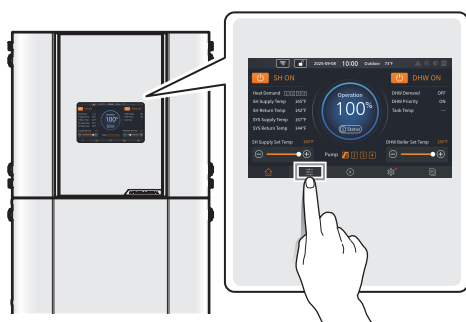

10.6.1 Viewing Basic Information

To view information about the boiler, tap the Control button () > **Status** on the screen.



The system information or status can also be accessed by tapping the **Status** inside the operation indicator circle on the home screen.



Item	Description
1. SH Set Temp	Space heating set temperature (°F)
2. DHW Set Temp	DHW indirect supply temperature (°F)
3. SH Supply Temp	Heating supply temperature (°F)
4. SH Return Temp	Boiler return temperature (°F)
5. System Supply Temp	System supply temperature (°F)
6. System Return Temp	System return temperature (°F)
7. Outdoor Temp	Outdoor temperature (°F)
8. Exhaust Temp	Exhaust temperature (°F)
9. Approx. Boiler Flow	Flow rate (GPM)

Item	Description
10. Flame Value	Flame detector AD value <ul style="list-style-type: none"> Flame On: 8bit AD values equal to or lower than 70 Flame Off: 8bit AD values equal to or higher than 175
11. Heat Capacity	Heat capacity (%)
12. Target RPM	Set fan speed (RPM)
13. Current RPM	Fan speed (RPM)
14. Target APS	Target APS voltage (V)
15. Current APS	APS voltage (V)

10.6.2 Setting the Space Heating Operation

To set the boiler's space heating operation, tap the Control button () > **SH Control** on the screen.



Tap an item to set the space heating operation settings.

Item	Description
1. SH Control Method	Select a heating control type. <ol style="list-style-type: none"> Supply: Supply temperature Return: Return temperature System Supply: System Supply temperature System Return: System Return temperature <ul style="list-style-type: none"> Default: Supply

Item	Description
2. Pump1 Setting	Set the Pump1. <ul style="list-style-type: none"> Zone1 Pump: The DHW pump is not used and four zone pumps are available DHW Pump: The DHW pump is used and three zone pumps are available Default: DHW Pump
3. Zone Setting	Enable or disable the zone-specific temperature control function. <ul style="list-style-type: none"> Default: Disable <p>Note</p> <p>If enabled, you can set the zone priority by tapping Priority Set. For more information about the zone-specific temperature control, refer to "Setting Zone-Specific Temperature Control Function in Detail" on page 96.</p>
4. Outdoor Reset / Detailed Settings	Set the Outdoor Reset Control function. <p>Note</p> <p>For more information about detailed settings, refer to "Setting Outdoor Reset Control Function in Detail" on page 96.</p>

Item	Description
5. SH Set Temp	<p>Set space heating target temperature.</p> <ul style="list-style-type: none"> Supply set temperature <ul style="list-style-type: none"> Setting range: 104°F (40°C)-180°F (82°C) Default: 180°F (82°C) Return set temperature <ul style="list-style-type: none"> Setting range: 86°F (30°C)-149°F (65°C) Default: 149°F (65°C) <p>Note</p> <p>To change the setting ranges, tap the Set button  > Parameter on the screen, and then adjust the values for the Supply/Return absolute Min/Max point items. For more information about detailed settings, refer to “10.7.4 Setting the Operation Parameters” on page 104.</p>

CAUTION

An outdoor sensor error may occur if the Outdoor Reset Control mode is enabled without the outdoor sensor installed.

Note

In the Outdoor Reset Control mode, the boiler’s water temperature is regulated according to the outdoor temperature to maximize boiler efficiency and reduce energy usage.

Setting Zone-Specific Temperature Control Function in Detail

This function allows you to set different temperatures for each zone. If Zone Setting is enabled, you can set the temperature for each zone and each zone will be controlled by the set temperature. If simultaneous demands for several zones occur, the temperature will be controlled by the zone with higher priority. You can set the priority in the pop-up window that appears when tapping **Priority Set**. This function is disabled automatically if Outdoor Reset, BMS Status, and Navien zone controller are enabled.

In cascade mode, two types of space heating modes are available depending on the settings for the Zone Setting menu.

- When Zone Setting is enabled: Zone-specific temperatures are applied and up to four zone pumps connected to the main unit are available.
- When Zone Setting is disabled: The temperature of SH Set Temp is applied and every zone pump of the main unit and subunits are available.

Setting Outdoor Reset Control Function in Detail

To set the outdoor reset control function in detail, tap **Detailed Settings** on the Outdoor Reset menu.



Item	Description
1. Outdoor Reset	<p>Enable or disable the outdoor reset function.</p> <ul style="list-style-type: none"> Default: Enabled
2. Min	<p>Set the minimum outdoor reset temperature for outdoor reset control.</p> <ul style="list-style-type: none"> Setting range: -4°F (20°C)-[Max-9°F (5°C)] Default: 14°F (-10°C)

Item	Description
3. Max	Set the maximum outdoor reset temperature for outdoor reset control. <ul style="list-style-type: none"> Setting range: [Min + 9°F (5°C)]-104°F (40°C) Default: 70°F (21°C)
4. Curve select	Select the outdoor reset load. <ul style="list-style-type: none"> Default: Finned Tube Baseboard
5. WWSD Temperature	Enable or disable the Warm Weather Shut Down temperature function. <ul style="list-style-type: none"> Setting range: OFF, 50°F (10°C)-104°F (40°C) Default: OFF <p>Note</p> <p>If the outdoor reset temperature exceeds the set temperature, all SH demands are ignored.</p>
6. WWSD On Differential	Enable or disable the Warm Weather Shut Down On Differential temperature function. <ul style="list-style-type: none"> Setting range: 0°F (0°C)-36°F (20°C) Default: 5°F (3°C) <p>Note</p> <p>If the outdoor reset temperature is lower than the set temperature, this feature is enabled depending on SH demands.</p>
7. Boost Interval Time	Set the boost interval set time (min). <ul style="list-style-type: none"> Setting range: 0-120 min Default: 0 min

Note To change the set temperature range (Y-axis in the graph), tap the Set button  > **Parameter** on the screen, and then adjust the values for the Supply/Return absolute Min/Max point items. For more information about detailed settings, refer to “10.7.4 Setting the Operation Parameters” on page 104.

10.6.3 Setting the DHW Operation (Indirect)

To set the boiler’s indirect DHW operation, tap the Control button  > **DHW Control** on the screen.



Tap an item to set the DHW operation settings.

Item	Description
1. DHW Demand	Select a device for sensing the DHW demand. <ol style="list-style-type: none"> Aquastat Tank Sensor <ul style="list-style-type: none"> Default: Aquastat
2. DHW Control Method	Select a DHW control type. <ol style="list-style-type: none"> Supply System Supply <ul style="list-style-type: none"> Default: Supply
3. Anti Legionella* function	Enable or disable the protection against legionella bacteria. <ul style="list-style-type: none"> Setting range: ON/OFF Default: OFF
4. DHW Tank Set Temp	Set the DHW tank target temperature. <ul style="list-style-type: none"> Setting range: 86°F (30°C)-[Supply Absolute MAX Set-point-18°F (10°C)] Default: 122°F (50°C)

Item	Description
5. DHW Boiler Set Temp	<p>Set the DHW boiler target temperature. The setting range varies depending on the DHW demand types.</p> <ul style="list-style-type: none"> When an aquastat is used, the setting range is same as the DHW temperature setting range. When a tank sensor is used: <ul style="list-style-type: none"> [DHW Tank Set temp + 18°F (10°C)]-Supply Absolute MAX Set-point 180°F (82°C) Default: 180°F (82°C)
6. DHW Priority time	<p>Set the DHW priority time.</p> <ul style="list-style-type: none"> Setting range: 0-180 min Default: 30 min

Note To change the absolute max values of the DHW tank set temperature and the DHW boiler set temperature, tap the Set button (⚙️) > **Parameter** on the screen, and then adjust the values for the Supply Absolute Max Set-point items. For more information about detailed settings, refer to “10.7.4 Setting the Operation Parameters” on page 104.

*This function will provide protection from growth of legionella bacteria in the DHW tank only. It will not protect water supply piping.

⚠️ CAUTION

A mixing valve must be installed on the DHW supply line when this mode is enabled as water temperatures will exceed 140°F (60°C).

10.6.4 Viewing Error History

When an error occurs, an error code is displayed on the status display in the center of the screen. If you tap the status display on the screen, an error pop-up will be displayed.

Note To enter the Error menu and view the error history, tap the History log button (📄) on the main screen, then tap an error history item in the top left of the screen.

To view the error history, tap **Open** in the pop-up window. To return to the main screen, tap **Close**.

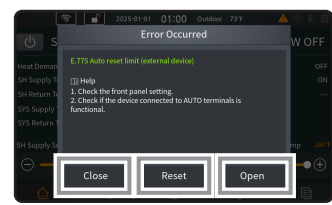

Errors are displayed on the screen, with the error codes, time of occurrence, and the total run time.

Tap **Done** to return to the previous screen or menu.

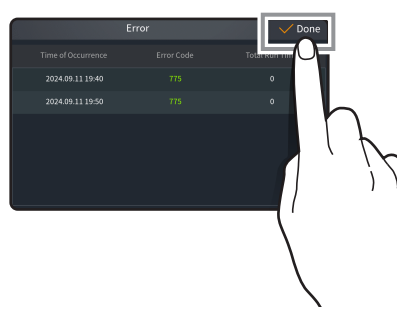

10.6.5 Viewing Other System Information

To view the miscellaneous system information, tap the EMS button (🔌) > **EMS Info** on the screen.

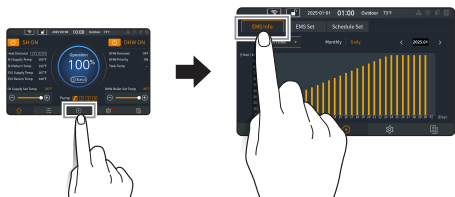

Tap the dropdown button (▼) to switch between the information items.

Item	Description
SH Run Time	View space heating operation logs. <ul style="list-style-type: none"> Display option: Monthly/Daily
DHW Run Time	View DHW operation logs. <ul style="list-style-type: none"> Display option: Monthly/Daily
SH Gas Usage	View space heating gas consumption. <ul style="list-style-type: none"> Display option: Monthly/Daily <p>Note Gas consumption is calculated and shown as an estimate.</p>
DHW Gas Usage	View DHW gas consumption. <ul style="list-style-type: none"> Display option: Monthly/Daily
Live Status	View current Status values.

10.6.6 Setting General Building Management System (BMS) Information

To set the general Building Management System (BMS) information, tap the EMS button (🔌) > **EMS Set** on the screen.



Item	Description
1. BMS Status	Enable or disable the Building Management System (BMS) function.
2. BMS Status / Detailed Settings	Set the Building Management System (BMS) function. <p>Note For more information about detailed settings, refer to "Setting Detailed Building Management System (BMS) information" on page 100.</p>
3. Modbus RTU	Enable or disable the Modbus RTU function. <ul style="list-style-type: none"> Default: Disabled If Enabled is selected, you can use Modbus communication.
4. Baud Rate Setting	Set the Baud rate and parity type. <ul style="list-style-type: none"> Default: 9600
5. Address Setting	Set the BMS Communication Protocol address. <ul style="list-style-type: none"> 0: Broadcast messages 1-100: Available address numbers for each unit Default: 1

Item	Description
6. Time Out Setting	<p>Set the timeout after transmission.</p> <ul style="list-style-type: none"> Setting range: 100 ms-1000 ms Default: 100 ms

Note

- BMS setting values will be specified and provided based on the building's control system. For more information, contact the controls provider or installer.
- For more details on how to set up BMS gateway, refer to the Modbus/BACnet or LonWorks Installation and Operation Manuals.

Setting Detailed Building Management System (BMS) information

The boiler's firing rate and set point can be controlled by 0-10 V Building Management System (BMS) input, if BMS Status is set to **Enabled**. If BMS Status is set to **Disabled**, 0-10 V Building Management System (BMS) input is ignored. To set the detailed Building Management System (BMS) information, tap **Detailed Settings** on the BMS Status menu.



Item	Description
1. Min (Firing rate)	<p>Set the minimum firing rate for BMS control.</p> <ul style="list-style-type: none"> Setting range: 0.1%-[2. Max (Firing rate) - 20%] Default: Boiler MIN HC
2. Max (Firing rate)	<p>Set the maximum firing rate for BMS control.</p> <ul style="list-style-type: none"> Setting range: [1. Min (Firing rate) + 20%]-100% Default: 100%

Item	Description
3. Min (Volts)	<p>Set the minimum voltage for BMS control.</p> <ul style="list-style-type: none"> Setting range: 0 V-[Volts Max - 1 V] Default: 2 V
4. Max (Volts)	<p>Set the maximum voltage for BMS control.</p> <ul style="list-style-type: none"> Setting range: [Volts Min + 1 V]-10 V Default: 10 V
5. BMS mode	<p>Select the BMS mode (Firing rate or Setpoint).</p> <ul style="list-style-type: none"> Default: Firing Rate
6. BMS Enable Volts	<p>Set the BMS activation voltage. Boilers operates when the input voltage exceeds the set voltage.</p> <ul style="list-style-type: none"> Setting range: 0 V-10 V Default: 2 V
7. BMS off Differential	<p>Set the BMS off differential voltage. Boiler stops operating when the input differential voltage is lower than the set voltage.</p> <ul style="list-style-type: none"> Setting range: 0 V-BMS Enable Volts Default: 0.5 V

10.6.7 Setting Schedule



If Status is set to **Enabled**, the boiler will turn on or off depending on the set schedule. The schedule setting feature is deactivated if Status is set to **Disabled**.

This feature is performed repeatedly on the set day and time, and you can create up to 30 schedules. If you set the schedule mode to **Off**, the boiler will stop operating, regardless of the demand.

10.6.8 Setting General Options

To set up general options, tap the Set button (⚙️) > **General** on the screen.



Swipe the screen upwards to see the next items.

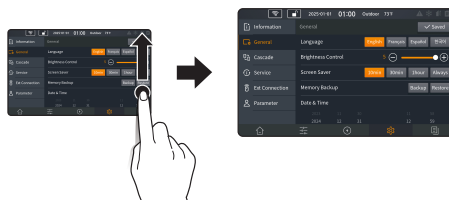

Item	Description
1. Language	<p>Select a display language.</p> <ol style="list-style-type: none"> 1. English 2. Français (French) 3. Espanol (Spanish) 4. 한국어 (Korean) <ul style="list-style-type: none"> • Default: English
2. Brightness Control	<p>Set the brightness level.</p> <ul style="list-style-type: none"> • Setting range: 0-5 • Default: 5
3. Screen Saver	<p>Set the time for the screen saver.</p> <ol style="list-style-type: none"> 1. 10min 2. 30min 3. 1hour 4. Always <ul style="list-style-type: none"> • Default: 10min
4. Memory Backup	<p>You can back up or restore the panel's memory, such as EMS information graph data.</p> <p>Select a memory management type.</p> <ol style="list-style-type: none"> 1. Backup 2. Restore <p>Note</p> <p>To back up data, the type of the file system for USB storage devices must be FAT32. Other types such as SanDisk Cruzer Blade USB flash drives cannot be used for memory backup.</p>

Item	Description
1. Date & Time	Set the date and time by swiping upwards or downwards.
2. Temperature Unit	<p>Set a temperature unit.</p> <ol style="list-style-type: none"> 1. Celsius (°C) 2. Fahrenheit (°F) <ul style="list-style-type: none"> • Default: Fahrenheit (°F)

Note

The temperature unit will change based on the selected language as follows.

- English : °F
- French : °C
- Spanish : °C
- Korean : °C

10.7 Accessing Advanced Menu Items

10.7.1 Viewing Service Information

To view service information about the boiler:

1. Tap the Set button  > **Service**.



2. Tap **Open** on the Service Status Information menu.

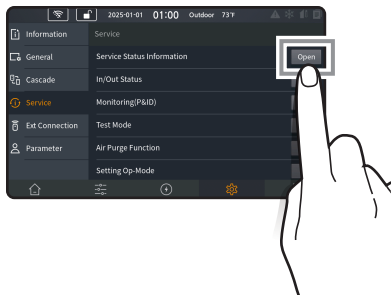

Item	Description
1. Elapsed time after install	Elapsed time since installation
2. HEX Overheat - No. of times	Number of heat exchanger overheating protection activation
3. Flame Loss - No. of times	Number of flame loss/ misfire
4. 2nd ignition - No. of times	Number of second ignition
5. 3rd ignition - No. of times	Number of third ignition
6. 4th ignition - No. of times	Number of fourth ignition
7. 5 ~10th ignition - No. of times	Number of tenth ignition

Item	Description
8. ΔT Limit - No. of times	Number of times supply return temperature limit control has activated
9. Supply Limit - No. of times	Number of times Recirculation supply temperature limit control has activated
10. ΔT High - No. of times	Number of times combustion stopped due to supply return temperature

10.7.2 Viewing Input and Output Status

To view the boiler's input and output status:

1. Tap the Set button  > **Service**.

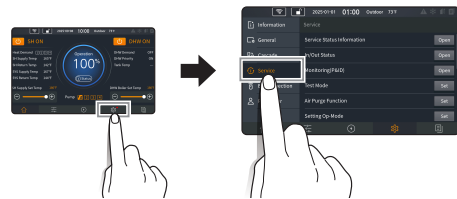

2. Tap **Open** on the In/Out Status menu.

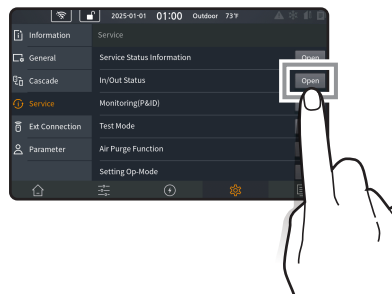

Item	Description
1. SH1 Thermostat Input	Space heating thermostat 1 input status
2. SH2 Thermostat Input	Space heating thermostat 2 input status
3. SH3 Thermostat Input	Space heating thermostat 3 input status
4. SH4 Thermostat Input	Space heating thermostat 4 input status
5. DHW Thermostat Input	DHW thermostat 1 input status
6. Boiler Pump Output	Boiler pump output status
7. Zone1 Pump Output	Zone 1 pump output status
8. Zone2 Pump Output	Zone 2 pump output status
9. Zone3 Pump Output	Zone 3 pump output status
10. Zone4 Pump Output	Zone 4 pump output status
11. Dual Venturi Output	Dual Venturi output status
12. LWCO Input	LWCO input status
13. Air Handler Output	Air Handler Interface output status
14. DHW Priority Output	DHW priority output status

2. Tap **Open** on the Monitoring (P&ID) menu.

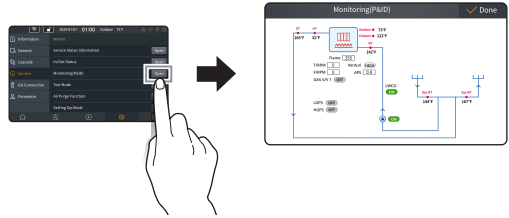

Item	Description
1. T/RPM	Target FAN RPM
2. F/RPM	Current FAN RPM
3. GAS V/V 1	Gas Valve
4. Venturi	Dual Venturi
5. APS	Current APS
6. Flame	Flame Current AD Value
7. RT	Return Temperature Sensor
8. ST	Supply Temperature Sensor
9. Sys ST	System Supply Temperature Sensor
10. Sys RT	System Return Temperature Sensor
11. HT	Overheating Detection Temperature Sensor
12. Exhaust	Exhaust Gas Temperature Sensor
13. Outdoor	Outdoor Temperature Sensor
14. LGPS	Low Gas Pressure Switch
15. HGPS	High Gas Pressure Switch
16. LWCO	Low Water Cut-Off Status
17. Boiler Pump	Boiler Pump Status

10.7.3 Viewing the Monitoring (P&ID) Values

To view the monitoring values for the boiler parts:

1. Tap the Set button > **Service**.



10.7.4 Setting the Operation Parameters

To set the boiler's operation parameters, tap the Set button  > **Parameter** on the screen.





On the password screen, enter the password.

The default factory password is "1234".

CAUTION

Parameters must be set by a qualified professional with an extensive understanding of the boiler system. Setting parameters improperly may lead to property damage or injury.

Note To save the parameter settings, tap the Save () button on the top right of the screen. If the parameter settings are saved successfully, the Saved () button will be displayed.

Item	Description
1. Supply Absolute MIN Set-point	Set the space heating supply minimum temperature. <ul style="list-style-type: none"> Setting range: 77°F (25°C)-[MAX Set-point - 36°F (20°C)] Default: 104°F (40°C)
2. Supply Absolute MAX Set-point	Set the space heating supply maximum temperature. <ul style="list-style-type: none"> Setting range: [MIN Set-point + 36°F (20°C)] - 190°F (88°C) Default: 180°F (82°C)

Item	Description
3. Return Absolute MIN Set-point	Set the space heating return minimum temperature. <ul style="list-style-type: none"> Setting range: 68°F (20°C)-[MAX Set-point - 18°F (10°C)] Default: 86°F (30°C)
4. Return Absolute MAX Set-point	Set the space heating return maximum temperature. <ul style="list-style-type: none"> Setting range: [MIN Set-point + 18°F (10°C)]-158°F (70°C) Default: 149°F (65°C)
5. SH Burner Off Differential	Set the temperature range to turn off space heating. <ul style="list-style-type: none"> Setting range: 2°F (1°C)-54°F (30°C) Default: 4°F (2°C)
6. SH Burner On Differential	Set the temperature range to turn on space heating. <ul style="list-style-type: none"> Setting range: 2°F (1°C)-54°F (30°C) Default: 5°F (3°C)
7. SH Min Limit	Set the space heating minimum heat capacity limit. <ul style="list-style-type: none"> Setting range: Space heating Min capacity (%)-[space heating min capacity limit -20] % Default: Boiler's minimum heat capacity
8. SH Max Limit	Set the space heating maximum heat capacity limit. <ul style="list-style-type: none"> Setting range: (Space heating Min capacity limit +20) %-100% Default: 100%
9. SH Min Burning Time	Set the low-load combustion time at initial operation. <ul style="list-style-type: none"> Setting range: 1-20 min Default: 1 min

Item	Description
10. Burning Acceleration Time	Set the time to reach the maximum space heating capacity after initial operation. <ul style="list-style-type: none"> Setting range: 0-20 min Default: 3 min
11. Anti Fast Cycling Time*	Set the anti-fast cycling time. <ul style="list-style-type: none"> Setting range: 0-20 min Default: 3 min
12. DHW Min Limit	Set the DHW supply minimum temperature. <ul style="list-style-type: none"> Setting range: DHW minimum capacity (%) - [DHW MAX capacity limit - 20] % Default: Boiler's minimum heat capacity
13. DHW Max Limit	Set the DHW supply maximum temperature. <ul style="list-style-type: none"> Setting range: [DHW Min capacity limit + 20] % - 100% Default: 100%
14. Freeze Protection	Set the pump freeze protection temperature. <ul style="list-style-type: none"> Setting range: 43°F (6°C) - 50°F (10°C) Default: 50°F (10°C) <p>Note</p> <p>The system freeze protection temperature is set based on the pump freeze protection temperature.</p>
15. Boiler pump operation(DHW)	Turn on or turn off the boiler pump in DHW mode. <ul style="list-style-type: none"> Setting range: ON/OFF Default: OFF
16. DHW Pump Operation	Turn on or turn off the DHW pump when space heating and DHW modes are required at the same time while using space heating mode. <ul style="list-style-type: none"> Default: ON Setting range: ON/OFF

Item	Description
17. Boiler Pump Delay	Set the SH pump over-run time. <ul style="list-style-type: none"> Setting range: 3-40 min Default: 40 min
18. DHW Demand On Differential	Set the DHW On temperature when using the DHW temperature sensor. <ul style="list-style-type: none"> Setting range: 0°F (0°C) - 18°F (10°C) Default: 5°F (3°C)
19. DHW Demand Off Differential	Set the DHW Off temperature when using the DHW temperature sensor. <ul style="list-style-type: none"> Setting range: 0°F (0°C) - 9°F (5°C) Default: 0°F (0°C)
20. ECM Pump Control	Set whether to use an ECM pump to vary the boiler pump speed, and set the control mode. <ul style="list-style-type: none"> Setting range: Disable, Max Flowrate, Variable Flowrate Default: Disable
21. ECM Pump Control Δ T Set-point	Set the Δ T (temperature difference) temperature for controlling the ECM pump. <ul style="list-style-type: none"> Setting range: 0-49°F (0-27°C) Default: 0°F (0°C)
22. Service Notification Time	Set the remaining time until the service notification. <ul style="list-style-type: none"> Setting range: 30-3650 days (10 years) It can be set in 1 day increments. Default: 1820 days (5 years)
23. Service Notification Cycle	Set the service notification according to the operating times. <ul style="list-style-type: none"> Setting range: 300-36500 cycles It can be set in 1 cycle increments. Default: 18200 cycles

Item	Description
24. Service Contact Phone Number	View the service contact information. <ul style="list-style-type: none"> • Default: 1-800-519-8794
25. Factory Reset	Initialize all parameter settings (panel and main controller) to factory default.
26. P/W Change	Change the parameter setting password.

Note

- If you enter an incorrect password 10 times or do not press any buttons for 5 minutes, the boiler will return to Normal mode.
- The Factory default password is "1234".
- When you reset one of the following parameters, the corresponding parameter will be reset automatically:
 - Supply Min or Max capacity limit
 - Return Min or Max capacity limit
 - Lowest Outdoor Temperature or Highest Outdoor Temperature

* The anti-fast cycling time is the duration that the boiler stops its space heating operation when the space heating supply or return temperatures reach the set values for boiler operation stop temperatures. The boiler will not resume space heating until the duration elapses, even when the space heating supply or return temperatures return to within the set ranges.

10.7.5 Configuring a Cascade System

To view and configure the cascade settings, tap the Set button (🔧) > **Cascade** on the screen.



Note

Prior to configuring a cascade system, verify that the communication cables are correctly installed and connected.

Item	Description
1. Setting Mode	<ul style="list-style-type: none"> • To enter the Cascade Setting Mode, tap Start. • The setting mode is entered and the IDs of all boilers that can communicate with the Main via the RS485 communication line are initialized. • If you tap and hold OK for 3 seconds or more while the boilers whose IDs are initialized by the Main are set to the Sub setting mode, the Main gives you the ID and it is displayed on the screen. • The Main periodically checks the RS485 communication, and when there is an ID request from the Sub, the ID is sequentially incremented and added to the Sub (1 to 7). • Tap OK in the Main to complete the cascade setting. In the Main and the Sub with assigned IDs, the pop-up windows will be closed and the cascade setting mode will be completed. • The Home screen is automatically changed into the cascade screen as soon as the cascade setting is complete. • In Main setting mode, if no input is detected for 60 minutes, the boiler resumes normal operation without cascading.

Item	Description
2. System Off	<p>Select this option on the main unit of a cascade system to end cascade operation.</p> <ul style="list-style-type: none"> Enter main setting mode to reassign IDs and begin a cascade system again. If a sub unit has a network communication problem, select this option on the sub unit to exclude the individual unit from the cascade system.
3. Operation Strategy	<p>Set the cascade strategy (control type).</p> <ul style="list-style-type: none"> Setting range: Comfort, ECO, Boost, Custom Default: ECO <p>Note</p> <p>For more detailed information on the operation strategies, refer to “Setting the Operation Strategy” on page 110.</p>
4. Vent Type	<p>Set the ventilation type.</p> <ul style="list-style-type: none"> Setting range: Common/ Individual Default: Individual
5. Initial Activating Units	<p>Set the number of initial activating units in the cascade system.</p> <ul style="list-style-type: none"> Setting range: 1-8 Default: 1

Swipe the screen up to go to the next page.

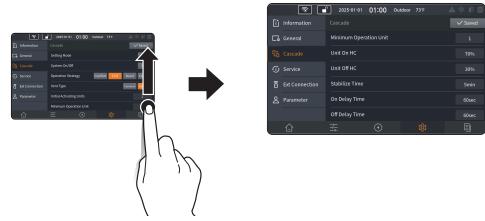

Item	Description
1. Minimum Operation Unit	<p>Set the minimum number of the boilers for the cascade system.</p> <ul style="list-style-type: none"> Setting range: 1-8 Default: 1
2. Unit On HC	<p>Set the heating capacity standard when adding boilers to the cascade system. (Applied if Operation Strategy is set to Custom.)</p> <ul style="list-style-type: none"> Setting range: (Unit Off HC + 20%)-(Max. Cascade heat - 5%) Default: 70%
3. Unit Off HC	<p>Set the heating capacity standard when removing the boilers for the cascade system. (Applied if Operation Strategy is set to Custom.)</p> <ul style="list-style-type: none"> Setting range: (Min. Cascade heat + 5%)-(Unit On HC - 20%) Default: 30%
4. Stabilize Time	<p>Set the stabilization time after changing the number of the boilers for the cascade system.</p> <ul style="list-style-type: none"> Setting range: 3-60 min Default: 5 min
5. On Delay Time	<p>Set the delay time when changing the number of the boilers for Cascade On mode.</p> <ul style="list-style-type: none"> Setting range: 30-240 sec Default: 60 sec

Item	Description
6. Off Delay Time	<p>Set the delay time when changing the number of the boilers for Cascade Off mode.</p> <ul style="list-style-type: none"> Setting range: 30-240 sec Default: 60 sec
7. Lead Rotation Type	<p>Set the rotation type for reassigning the lead boiler.</p> <ul style="list-style-type: none"> ID: The lead boiler is assigned in order of the boiler ID. Time: The lead boiler is assigned in the order of boilers with the shortest uptime during the time set in Lead Rotation Period. Default: ID
8. Force Lead Change	<p>Set Force Lead Change.</p> <ul style="list-style-type: none"> Yes: Reassign the lead boiler regardless of the demand status. No: Reassign the lead boiler when demands are off. Default: Yes
9. Lead Rotation Period	<p>The lead boiler changes automatically at the interval set in Lead Rotation Period to maintain the operation time of all boilers for the cascade system equally. (Boiler operation time standards)</p> <ul style="list-style-type: none"> Setting range: 2-1,000 hours Default: 24 hours

About the Cascade Operation Screens

After completing the cascade system configuration, the cascade operation screen for the main and sub boilers is displayed as follows. You can set the detailed information for the cascade system's main or sub boilers.

- Main screen
 - To adjust the heating temperature on the screen, tap or in the SH Set Temp menu or swipe on the middle of the SH Set Temp menu.
 - To allow the main boiler to operate, tap **Main**.
 - To allow the boilers to operate in the cascade system, tap **Cascade**.

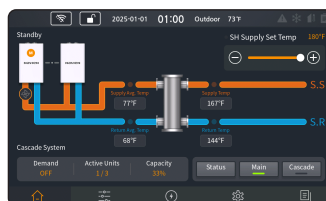

- Sub screen

To operate or stop operating the sub boilers, tap **ON/OFF**. You cannot adjust the space heating temperature of the sub boilers when the cascade system is configured.



10.7.6 Updating the Firmware (FOTA)

1. To perform a firmware update, tap the Set button  > **Information** > **Update**.

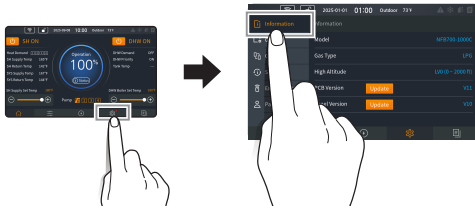

Note When the device is registered in the Navi-Link app, and the controller and panel are ready for update, the **Update** button next to **PCB Version** and **Panel Version** item is enabled.

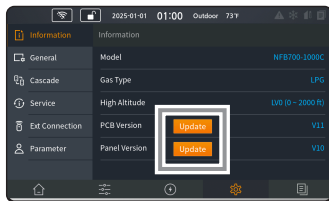

2. On the pop-up screen, verify the update version, and then tap **Done** to begin the update process.

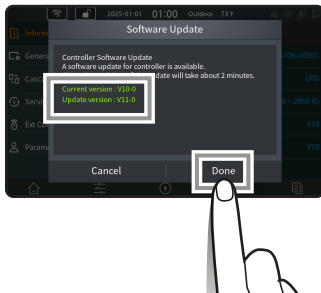

Note The update process takes approximately 5 minutes for the PCB and 16 minutes for the controller.

Setting the Operation Strategy

To set the operation strategy (operating algorithm), select the strategy from **Comfort** (default), **Eco**, or **Boost**. The detailed information for each mode is as follows.

	Comfort	Eco	Boost	Custom
Operating method	Late On/Early Off <ul style="list-style-type: none"> Unit On HC: 95% (Late Unit On) Unit Off HC: 30% (Late Unit Off) 	Early On/Late Off <ul style="list-style-type: none"> Unit On HC: 60% (Early Unit On) Unit Off HC: 30% (Late Unit Off) 	Late On/Early Off <ul style="list-style-type: none"> Unit On HC: 95% (Late Unit On) Unit Off HC: 50% (Early Unit Off) 	<ul style="list-style-type: none"> Unit On HC: The value of Unit On HC (Default: 70%) Unit Off HC: The value of Unit Off HC (Default: 30%)
Feature	Optimizes operation of the boiler by preventing frequent stops and starts.	Maximizes boiler efficiency.	Maximizes boiler responsiveness to call for heat.	On/Off cycles are determined by custom settings.
Condensing effectiveness	●●	●●●	●	
Heat responsiveness depending on a small amount of load changes	●●	●	●●●	
Heat responsiveness depending on a large amount of load changes	●●	●●●	●●	

• **Comfort**

This mode minimizes the amount of times the unit cycles ON and OFF. However, it requires additional unit operation time (Low Off HC). Refer to the following operating diagram for the detailed information.

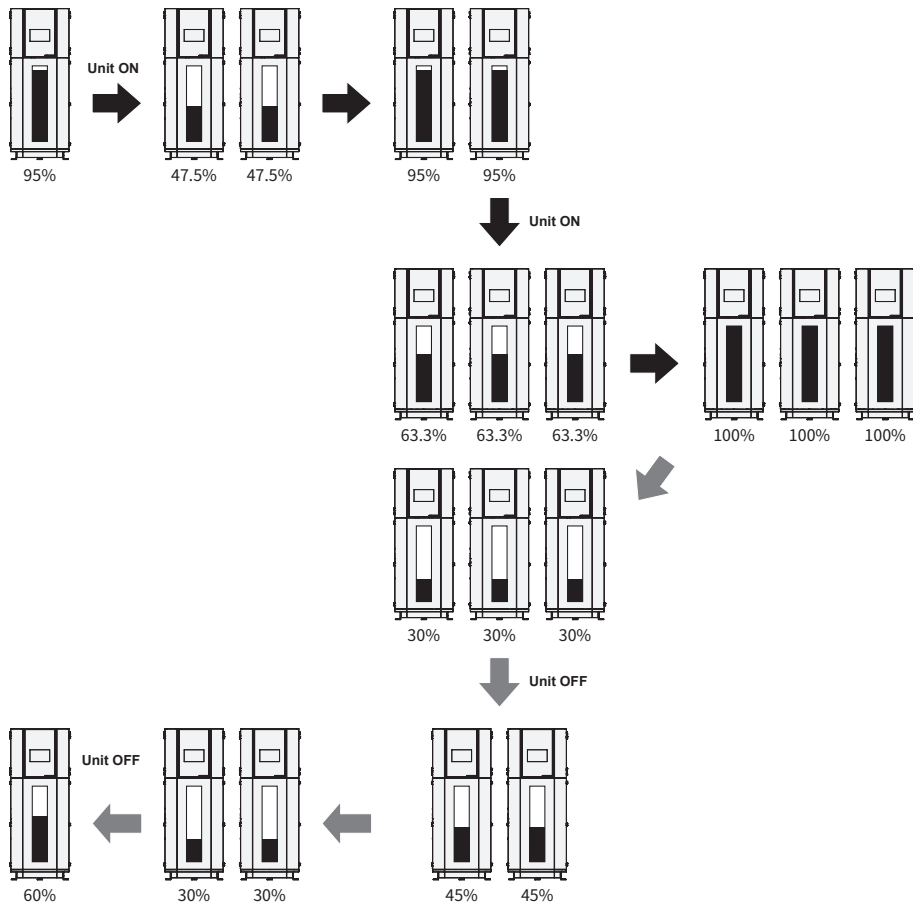

• **Eco**

This mode increases the condensing effectiveness and quickly responds to a large amount of load changes. However, it requires additional unit operation time (Low Off HC) and sensitively responds to a small amount of load changes (Small On/Off gap).

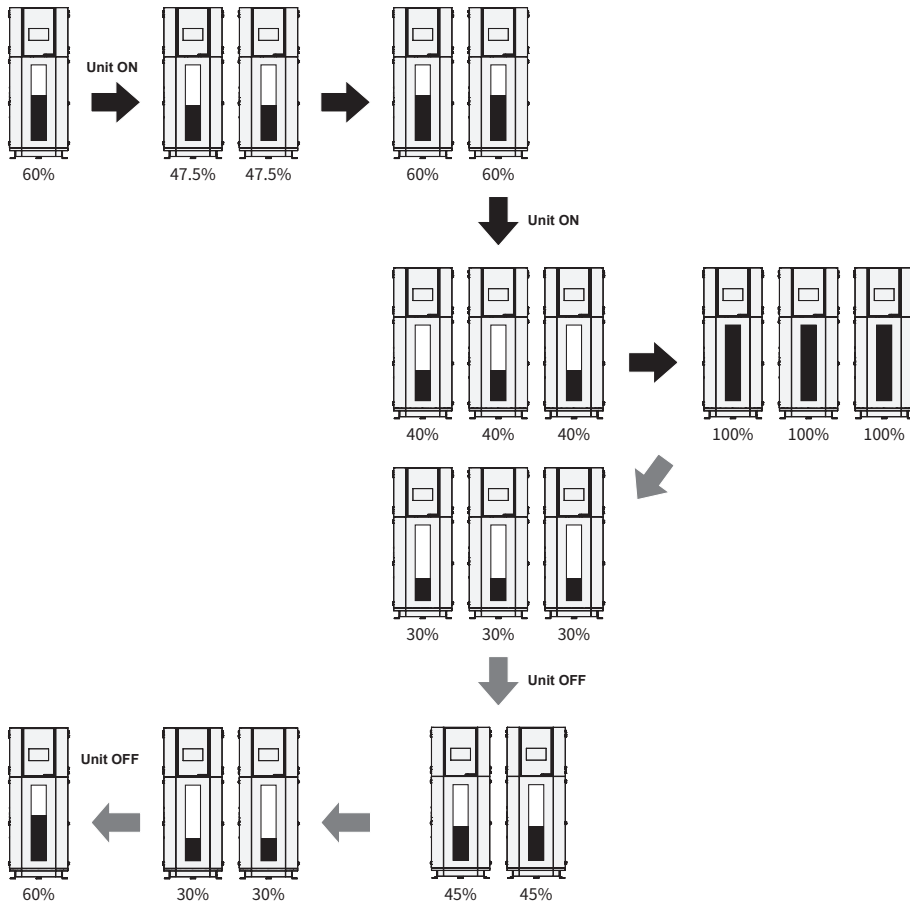

• **Boost**

This mode minimizes the total unit operation time. However, it decreases the condensing effectiveness.

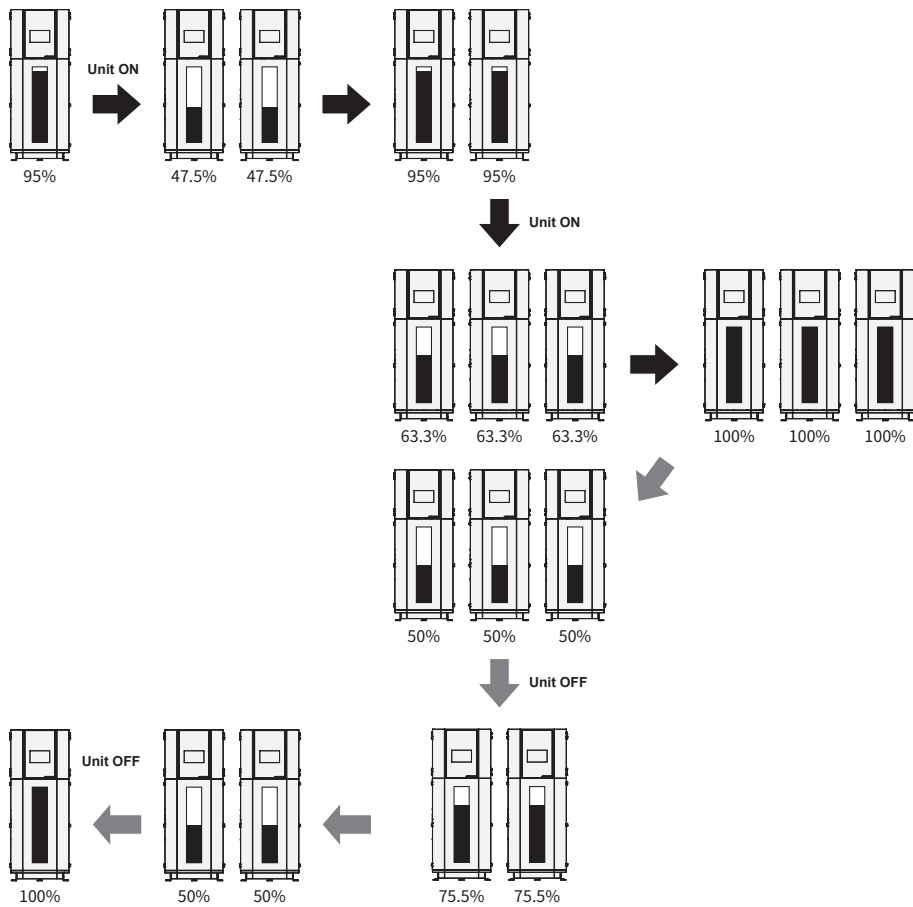

10.7.7 Setting the External Connection

To view and configure the external network connection, tap the Set button (⚙️) > **Ext Connection** on the screen.

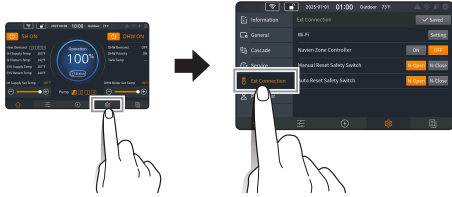

Item	Description
1. Wi-Fi	Set up the Wi-Fi connection. After connecting to Wi-Fi, a QR code for linking with the Navi-Link mobile app is generated. Device registration is performed when the mobile app recognizes the QR code.
2. Navien zone controller	Turn on or turn off the Navien zone controller. <ul style="list-style-type: none"> Setting range: ON/OFF Default: OFF
3. Manual Reset Safety Switch	Select the manual reset safety switch (contact) type. <ul style="list-style-type: none"> Default: N-Open (Normal Open)
4. Auto Reset Safety Switch	Select the Auto reset safety switch (contact) type. <ul style="list-style-type: none"> Default: N-Open (Normal Open)

10.7.8 Diagnosing the Boiler System

To run a series of test procedures for a system diagnosis:

1. Tap the Set button (⚙️) > **Service**.



2. Tap **Set** on the Test Mode menu. The Test Mode pop-up is displayed on the screen.

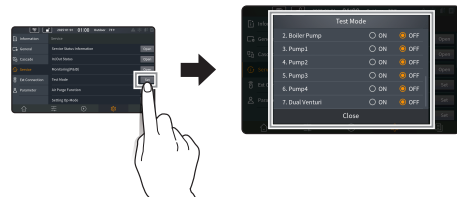

Item	Description
1. Fan	Test the fan operation by manually changing the fan speed. <ul style="list-style-type: none"> From a stopped state, the fan speed gradually increases and reaches the top speed, and then the fan speed decreases until the fan stops operating. Tap ON or OFF to toggle the fan test (ON -> OFF / OFF -> ON).
2. Boiler pump	Test the boiler pump operation. <ul style="list-style-type: none"> The boiler pump is turned on as soon as you enter the test mode. Tap ON or OFF to toggle the pump operation (ON -> OFF / OFF -> ON).

Item	Description
3. Pump 1	<p>Test the pump 1 operation.</p> <ul style="list-style-type: none"> The pump 1 is turned on as soon as you enter the test mode. Tap ON or OFF to toggle the pump operation (ON -> OFF / OFF -> ON).
4. Pump 2	<p>Test the pump 2 operation.</p> <ul style="list-style-type: none"> The pump 2 is turned on as soon as you enter the test mode. Tap ON or OFF to toggle the pump operation (ON -> OFF / OFF -> ON).
5. Pump 3	<p>Test the pump 3 operation.</p> <ul style="list-style-type: none"> The pump 3 is turned on as soon as you enter the test mode. Tap ON or OFF to toggle the pump operation (ON -> OFF / OFF -> ON).
6. Pump 4	<p>Test the pump 4 operation.</p> <ul style="list-style-type: none"> The pump 4 is turned on as soon as you enter the test mode. Tap ON or OFF to toggle the pump operation (ON -> OFF / OFF -> ON).
7. Dual Venturi	<p>Test the dual venturi operation.</p> <ul style="list-style-type: none"> The dual venturi is turned on as soon as you enter the test mode. Tap ON or OFF to toggle the dual venturi operation (ON -> OFF / OFF -> ON).

10.7.9 Setting the Operation Modes

To operate the boiler in special operation modes:

1. Tap the Set button (⚙️) > **Service**.



2. Tap **Set** on the Setting Op-mode menu. The Setting Op-mode pop-up is displayed on the screen.

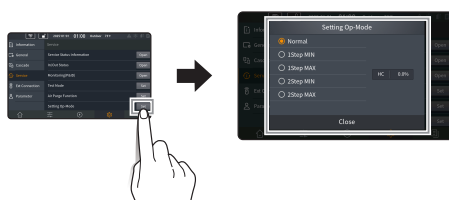

Tap an item to set the operation modes.

The boiler resumes operation in normal operation mode if no input is detected for 3 hours.

Item	Description
1. Normal	Set the boiler to run in Normal operation mode.
2. 1Step MIN	Set the boiler to run in 1st step minimum operation mode.
3. 1Step MAX	Set the boiler to run in 1st step maximum operation mode.
4. 2Step MIN	Set the boiler to run in 2nd step minimum operation mode.
5. 2Step MAX	Set the boiler to run in 2nd step maximum operation mode.

10.7.10 Operating in Air Purge Mode

To operate the boiler in air purge mode:

1. Tap the Set button (⚙️) > **Service**.



2. Tap **Set** on the Air Purge Function menu. The Air Purge Function pop-up is displayed on the screen.

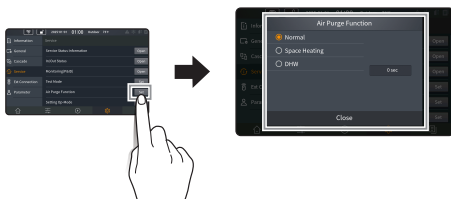

Tap an item to set the parameters for an air purge.

The boiler resumes operation in normal operation mode if no input is detected for 15 minutes.

Item	Description
1. Normal	Set the boiler to run in Normal operation mode without an air purge.
2. SH	Run an air purge on the space heating piping.
3. DHW	Run an air purge on the DHW piping.

10.7.11 Running Smart Diagnosis

To operate the boiler in Smart Diagnosis mode:

1. Tap the Set button (⚙️) > **Service**.



2. Tap **Start** on the Smart Diagnosis menu. The Smart Diagnosis pop-up is displayed on the screen.

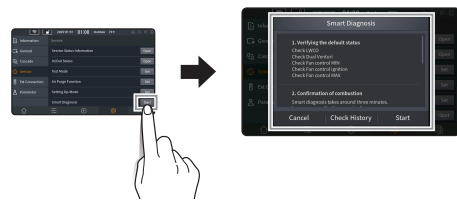

3. Tap **Start** to use Smart Diagnosis.

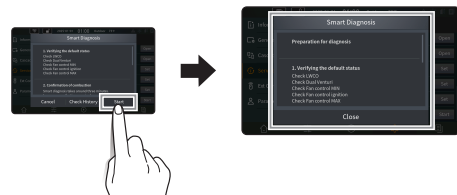

Smart Diagnosis Process

Running Smart Diagnosis consists of four main steps:

1. Change the boiler to standby mode and perform the necessary preparations to start Smart Diagnosis.
2. Check the following operation states:
 - LWCO
 - Dual Venturi
 - FAN control (Min)
 - FAN control (Ignition)
 - FAN control (Max)
3. Run the combustion operation and verify ignition.
4. When Smart Diagnosis completes, the pop-up will close automatically, and the Smart Diagnosis Report pop-up will be displayed.



Note

- The smart diagnosis report is categorized as either a normal report or an error report, depending on whether the diagnosis was completed normally or not.
- A maximum of five reports can be stored. If the maximum number of reports is reached, the oldest report will be deleted to save the most recent one.

Managing the Diagnostic Report

1. On the Smart Diagnosis pop-up screen, tap **Check History** to view the diagnostic reports.

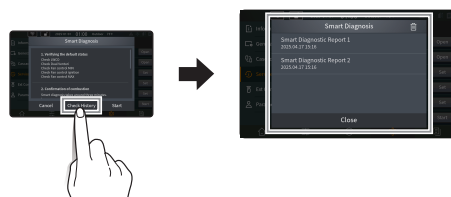

2. Tap the delete button (🗑️) at the top right of the pop-up screen to select the item, and then tap **Delete** to delete the reports.

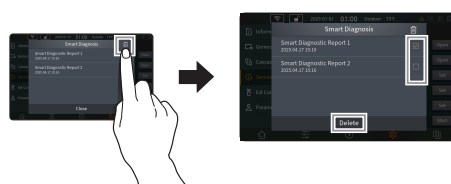

10.8 Understanding Error Codes

When an error code appears on the front panel, refer to the following chart for a definition and possible remedy for the situation.

Error Code	Reason	Self-diagnostic/Action
E001	Heat exchanger over temperature	Auto reset/Manual reset/Power On reset
E003	Ignition failure	Manual reset/Power On reset
E004	False flame detection	Auto reset
E012	Flame loss	Manual reset/Power On reset
E016	Heat exchanger overheat	Manual reset/Power On reset
E020	Abnormal operation: gas valve	Manual reset/Power On reset
E030	Abnormal operation: exhaust temperature	Auto reset/Manual reset/Power On reset
E031	Burner overheating	Contact Technical Support.
E047	Abnormal operation: exhaust thermostat	Auto reset/Manual reset/Power On reset
E059	Abnormal operation: overheat temperature sensor	Auto reset
E060	Abnormal operation: dual venturi	Alarm
E109	Abnormal operation: fan motor	Manual reset/Power On reset
E110	Exhaust vent blocked	Manual reset/Power On reset
E123	Abnormal operation: fan output	Manual reset/Power On reset
E127	Abnormal operation: APS	Alarm
E205	Abnormal operation: heating supply thermistor	Auto reset
E218	Abnormal operation: heating return thermistor	Alarm
E278	Abnormal operation: system supply thermistor	Alarm
E279	Abnormal operation: system return thermistor	Alarm
E291	Supply/Return inversion limit	Manual reset/Power On reset
E480	Abnormal operation: DHW tank temperature sensor	Alarm
E515	Abnormal operation: PCB component	Alarm/Manual reset/Power On reset
E517	Abnormal operation: DIP switch setting (PCB)	Manual reset/Power On reset
E594	Abnormal operation: EEPROM (PCB)	Alarm
E615	Abnormal operation: MCU	Alarm/Auto reset/Manual reset/Power On reset
E706	Abnormal operation: air damper input	Manual reset/Power On reset
E736	Abnormal operation: Cascade communication	Alarm
E740	Abnormal operation: outdoor temperature sensor	Alarm
E744	Abnormal operation: louver switch input	Manual reset/Power On reset

Error Code	Reason	Self-diagnostic/Action
E765	Abnormal external-pump	Alarm
E769	High Gas Pressure Switch	Manual reset
E772	Low Gas Pressure Switch	Manual reset
E774	Manual reset limit	Manual reset
E775	Auto reset limit	Auto reset
E777	Low Water Cut Off	Manual reset
E782	Abnormal operation: boiler communication	Alarm
E784	Abnormal operation: zone controller communication (external device)	Alarm
E788	Abnormal operation: Gas type settings	Manual reset

If these remedies do not resolve the problem, refer to the "Corrective Procedures for Error Codes section" in the Service Manual for detailed information or contact Technical Support at 1-800-519-8794.

11. Appendixes

11.1 Gas & High Altitude Conversion

This boiler is configured for Natural Gas at the factory.

- If conversion to Propane Gas is required by the boiler, use the PROPANE GAS & HIGH ALTITUDE CONVERSION supplied with the boiler.
- If the boiler is installed at a high altitude (above 5,400 ft) for NG, use the NATURAL GAS HIGH ALTITUDE CONVERSION KIT supplied with the boiler.

Note For Propane Gas or high altitude conversion, use the PROPANE GAS & HIGH ALTITUDE CONVERSION. Note that the Gas Orifice from the PROPANE GAS & HIGH ALTITUDE CONVERSION covers the boiler's installation at an altitude of 0 to 10,100 ft.

DANGER

DO NOT perform a gas & High Altitude conversion without an officially approved conversion kit and the instructions supplied by Navien. Gas & High Altitude conversion using any other parts will result in extremely dangerous burner operation, leading to fire, explosion, severe personal injury or death.

Note High Altitude Conversion kit (a) and Propane Gas & High Altitude Conversion kit (b) are included in the accessory box.

DANGER

Fire and Explosion Hazard

To prevent serious injury or death:

- ONLY a qualified installer, service agency, or the gas supplier* is required to install a conversion kit in accordance with Navien's instructions and all applicable codes and requirements of the authority having jurisdiction.
- The qualified installer, service agency, or the gas supplier* is responsible for the proper installation of this kit. The installation is not proper and complete until the operation of the converted appliance is checked as specified in the manufacturer's instructions supplied with the kit.

BEFORE starting the gas conversion:

- ALWAYS turn off electrical power supply to the boiler and close the manual gas shut-off valve.
- ALLOW the boiler to cool if it has been operating.
- For propane boilers: The propane supplier mixes an odorant with the propane to make its presence detectable. In some instances the odorant can fade, and the gas may no longer have an odor. Before startup (and periodically thereafter), have the propane supplier verify the correct odorant level in the gas.

* A qualified installer, service agency, or the gas supplier is any individual, firm, corporation or company which either in person or through a representative is engaged in and is responsible for the connection, utilization, repair or servicing of gas utilization equipment or accessories; who is experienced in such work, familiar with all precautions required, and has complied with all of the requirements of the authority having jurisdiction.

In Canada: The conversion shall be carried out in accordance with the requirements of the provincial authorities having jurisdiction and in accordance with the requirements of the CAN-B149.1 and CAN1-B149.2 Installation Code.



Tools Required:

- Phillips Screwdriver
- Flathead Screwdriver
- Torx T40 driver
- Torx T10 driver
- Combustion Analyzer or Dual Port Manometer
- Gas Leak Detector
- 10 mm Socket Wrench, Ratchet Wrench or T-Wrench

Included Items:

- Gas Orifice (Table 1)
- Gas Pipe Reducer (Brass) (800C and 1000C Propane models only)

NFB700-500C/600C Orifice Identification

Gas Type	Natural Gas		Propane Gas
Altitude	0-5,399 ft	5400-10,100 ft	0-10,100 ft
Orifice	 Natural Gas (Factory Installed)	 Natural Gas High Altitude	 Propane Gas & High Altitude
Orifice Size	Ø7.3/Ø10.3	Ø7.7/Ø11.5	Ø5.8/Ø7.9

NFB700-800C/1000C Orifice Identification



Gas Type	Natural Gas		Propane Gas
Altitude	0-5,399 ft	5400-10,100 ft	0-10,100 ft
Orifice	 Natural Gas (Factory Installed)	 Natural Gas High Altitude	 Propane Gas & High Altitude
Orifice Size	Ø9.4/Ø18.0	Ø10.2/ Remove 2nd orifice	Ø7.5/Ø12.5

Table 1. Orifice Size

Note

- For NFB700-800C/1000C Propane models, the gas pipe reducer included in the kit must be installed onto the gas inlet pipe after replacing the orifice.
- Please confirm the installation elevation by using the provided QR code to access the following website (<https://www.navieninc.com/elevation>) and entering the proper zip/postal code.

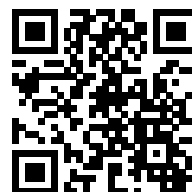

DANGER

Fire and Explosion Hazard

To prevent serious injury or death:

- Be careful not to confuse the PROPANE GAS & HIGH ALTITUDE CONVERSION. Do NOT use the NATURAL GAS HIGH ALTITUDE CONVERSION KIT for natural gas when converting to propane gas.
- Make sure that the conversion is completed with the proper orifice. If the installed orifice does not conform to the specifications in Table 1, incomplete combustion may occur, resulting in personal injury or property damage.

Procedure:

Note

- The procedure below can be applied to both Propane conversion and High Altitude conversion. Distinguish the kit supplied with the boiler before installing.
- A derate of 2.2% is required at this elevation.

1. Turn off the power, gas, and water supply to the boiler.
2. Unfasten the 4 latches on the upper sides of the boiler to remove the upper-front cover and gain access to the internal components.

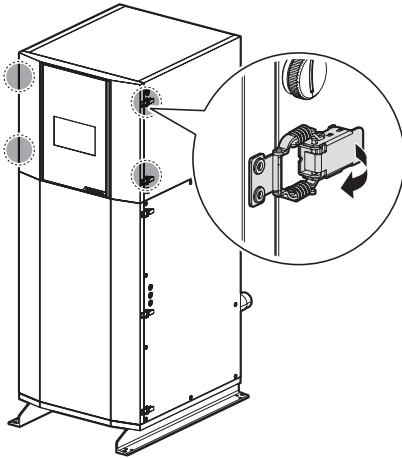

Figure 1. NFB700 Series Upper-front Cover

3. Remove the upper-front cover and place it in a safe location to prevent accidental damage.

4. Open the top cover and support it by using the prop rod inside the boiler.

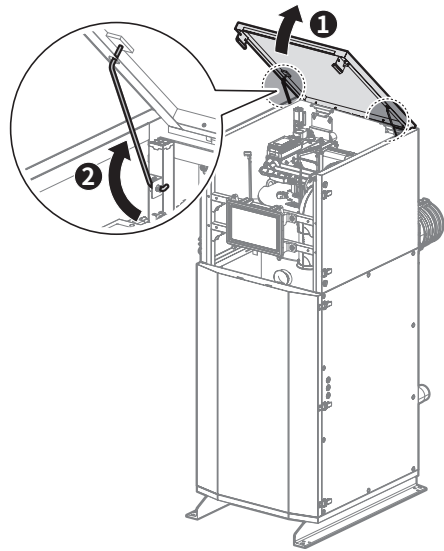

Figure 2. Supporting the Top Cover

5. Turn the 6 Thumbscrews counterclockwise to remove them from both the inside and outside of the boiler.

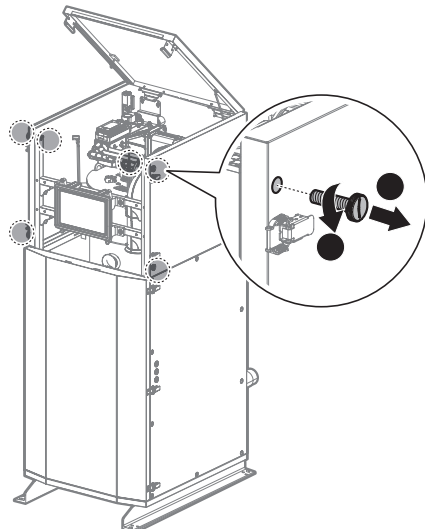

Figure 3. Removing the Thumbscrews

- Open the side covers horizontally, and then lift up to remove the covers from the boiler.

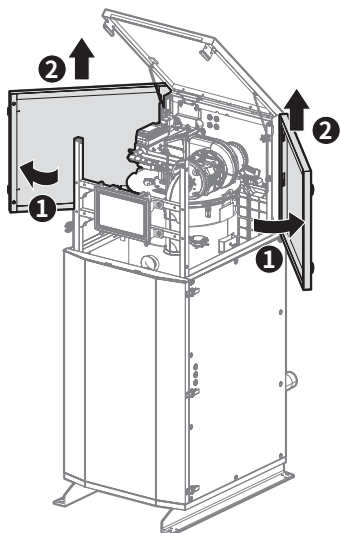

Figure 4. NFB700 Series Side Covers

- Remove the side covers and place them in a safe location to prevent accidental damage.
- With the internal components exposed, locate the gas inlet pipe and the gas valve.

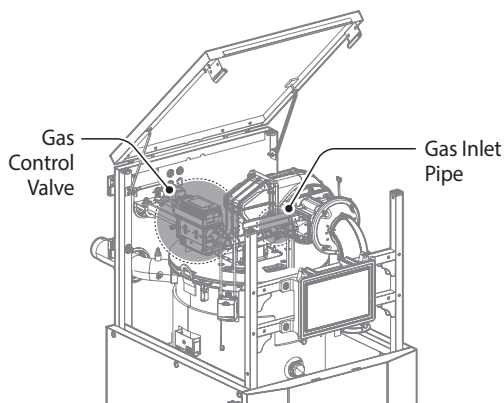

Figure 5. NFB700 Series Internal Components

- Carefully remove the four screws that secure the gas pipe and dual venturi to the gas valve and fan motor assembly using a 10 mm Socket Wrench, Ratchet Wrench or T-Wrench, and then pull the gas valve outlet adapter away from the dual venturi to access the gas orifice.

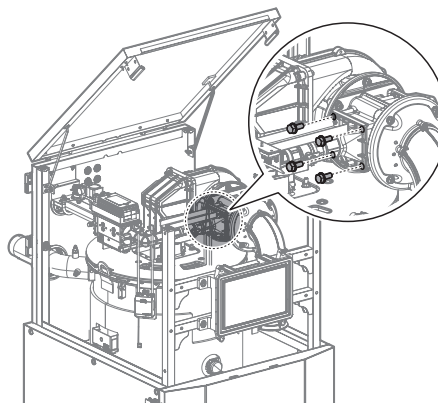

Figure 6. Detaching the Gas Valve Outlet Adapter from the Gas Valve and Fan Motor Assembly

- Once the gas orifice is exposed, remove the 4 screws that hold the part in place. Remove the gas orifice from its housing and prepare the new gas orifice for installation.

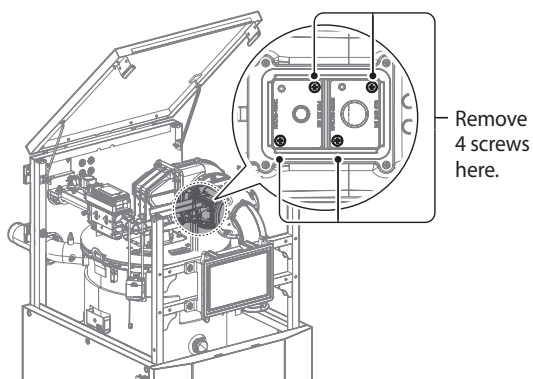

Figure 7. Access to the Gas Orifice in the Fan Assembly

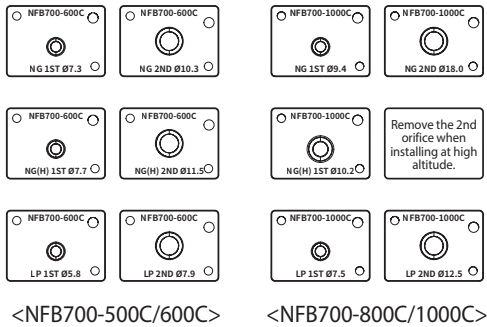
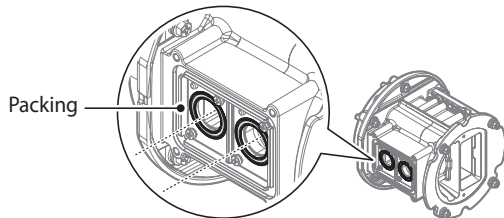

Figure 8. Orifice Identification

Note Remove the second orifice when converting a natural gas unit for high-altitude operation.

- Remove the gas orifice, ensure that the packing is properly seated inside the port, and then install the new gas orifice. Ensure that the orifice is properly seated on the packing inside the port before proceeding to the next step.



For NFB700-800C/1000C Propane models, install the gas pipe reducer included with the kit onto the gas inlet pipe after replacing the orifice. Secure the reducer by turning it clockwise until properly fixed.

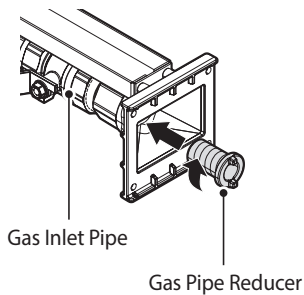

WARNING

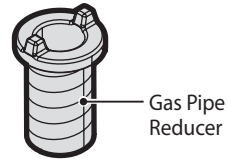

The gas pipe reducer must be installed onto the gas inlet pipe for NFB700-800C/1000C Propane models.

- Return the gas inlet pipe to its original position and use all screws to secure all connections.

Note Do not overtighten the screws as this may damage or crack the components.

DANGER

Inspect the O-ring between the gas valve and gas valve inlet adapter whenever they are disassembled. The O-ring must be in good condition and must be installed. Failure to comply will cause a gas leak, resulting in severe personal injury or death.

- Set the PCB DIP switch to change the gas type and high altitude settings. For propane gas, set Dip Switch 2 #1 to ON. For natural gas, set Dip Switch 2 #1 to OFF. For high altitude settings, set the Dip Switch 2 #2&3 based on the following table.

⚠ WARNING

Electric Shock Hazard

ALWAYS turn off power to boiler before accessing the DIP switches to prevent serious injury or death.

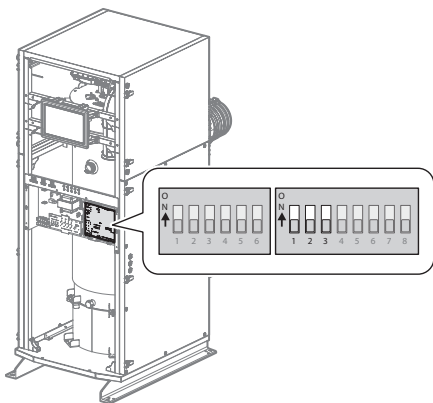

Switch	Function	Setting	Comment
1	Gas Type	Natural Gas	1-OFF
		Propane Gas	1-ON
2&3	High Altitude	0-1,999 ft (0-609m)	2-OFF, 3-OFF
		2,000-5,399 ft (610-1,645m)	2-ON, 3-OFF
		5,400-7,699 ft (1,646-2,346m)	2-OFF, 3-ON
		7,700-10,100 ft (2,347-3,078m)	2-ON, 3-ON
			Refer to Table 1 on page 121.

When applying the Gas Orifice for high altitude, set the PCB DIP switches by altitude according to the table above.

Note

- This unit may be installed at elevations up to 10,100 ft (3,078 m) for use with natural gas and propane. To use the unit at a specific altitude, the DIP Switches should be set as described above.
- Please confirm the installation elevation by using the provided QR code to access the following website (<https://www.navienc.com/elevation>) and entering the proper zip/postal code.



- For natural gas, if you install the unit at above 5,400 ft (1,646 m), it is required to change the Gas Orifice for high altitude. Be careful not to confuse it with the Gas Orifice for propane gas.
- Note that the Gas Orifice from the PROPANE GAS AND HIGH ALTITUDE CONVERSION KIT covers the boiler's installation at an altitude of 0 to 10,100 ft.

⚠ DANGER

To prevent serious injury or death:

- ALWAYS check the panel DIP switch 1 is set according to the supply gas type.
- For natural gas, only install the gas orifice for high altitude when the boiler is installed at above 5,400 ft.
- Be careful to install the Natural Gas High Altitude Conversion Kit and not to confuse it with the Propane Gas & High Altitude Conversion Kit.
- Failure to properly install the High Altitude Conversion Kit or to not use the appropriate Altitude Settings could cause carbon monoxide poisoning, resulting in serious injury or death.

14. Turn on the gas and water supply to the boiler.

15. Measure and adjust the gas/air ratio.

Option 1. Using Combustion Analyzer (recommended)

- a. Loosen the screw, rotate the plate and remove the gasket to access the emissions monitoring port as shown in Figure 9.
- b. Insert the analyzer into the port as shown in Figure 9.

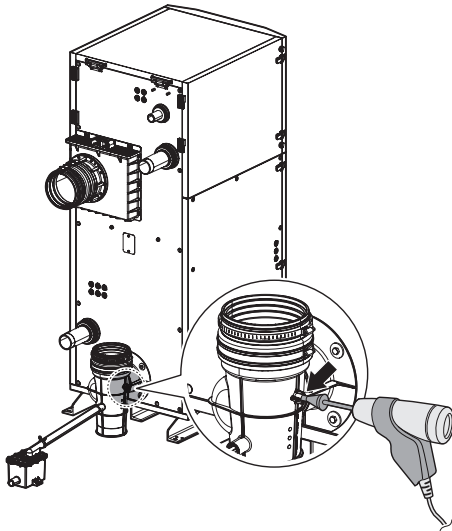

Figure 9. Insert the Analyzer

Model	Altitude	Fuel	High fire	Low fire
			%CO ₂	%CO ₂
NFB700-500C/600C	0-5,399 ft	NG	8.8	8.9
		Propane	10.3	10.7
	5,400-10,100 ft	NG	8.8	8.9
		Propane	10.3	10.7

Model	Altitude	Fuel	High fire	Low fire
			%CO ₂	%CO ₂
NFB700-800C/1000C	0-5,399 ft	NG	8.8	8.9
		Propane	10.3	10.7
	5,400-10,100 ft	NG	8.8	8.9
		Propane	10.3	10.7

Table 2. CO₂ value
(CO₂ values must be within 1.0% of the values listed.)

- c. Activate multiple zones and set the boiler to operate at 1Step MIN mode.

Note For operation mode selection, refer to “10.7.9 Setting the Operation Modes” on page 115.

Measure the CO₂ value at low fire. If the CO₂ value is not within 1.0% of the value listed in Table 2, the gas valve set screw will need to be adjusted. If adjustment is necessary, locate the set screw as shown in Figure 10. Using an Allen or Star Wrench, turn the set screw no more than ¼ turn clockwise to raise or counterclockwise to lower the CO₂ value.

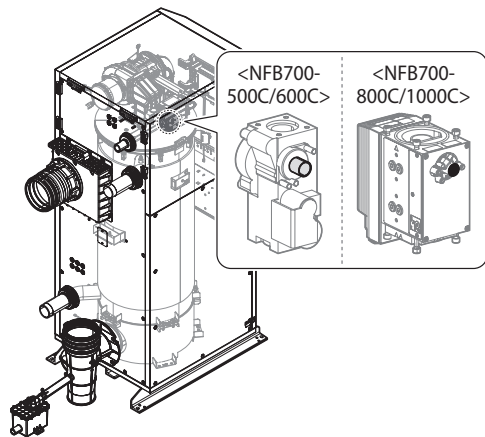

Figure 10. Set Screw Location

Note The set screw is located behind the screw-on cover. This must be removed first.

- d. Activate multiple zones and set the boiler to operate at 2Step MAX mode (refer to “10.7.9 Setting the Operation Modes” on page 115). Measure the CO₂ value at high fire. If the CO₂ values do not match Table 2 at high fire, do not adjust the gas valve. Check for the proper Gas Orifice.

⚠ DANGER

Improper gas valve settings can cause severe personal injury, death or substantial property damage.

Option 2. Using Digital Manometer

- a. Open the offset pressure port by loosening the screw two turns as shown in Figure 11.

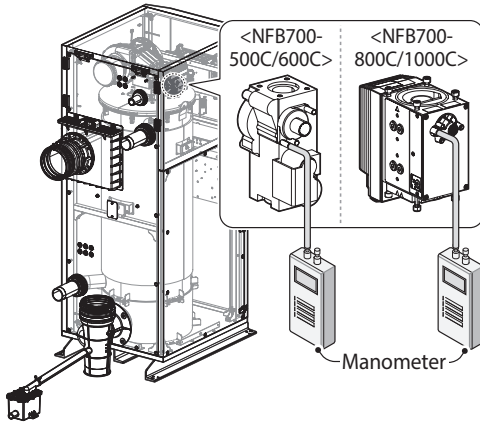

Figure 11. Connect Digital Pressure Manometer

- b. Connect a manometer to the offset pressure port. For dual port manometers, use the positive pressure side.

Model	Kit Part No.	Gas Type	Offset
NFB700-500C/600C	NAC-NH500/600	NG	-0.01in ± 0.01in
	NAC-L500/600	Propane	-0.01in ± 0.01in
NFB700-800C/1000C	NAC-NH800/1000	NG	-0.01in ± 0.01in
	NAC-L800/1000	Propane	-0.01in ± 0.01in

Table 3. Offset value for low fire

- c. Activate multiple zones and set the boiler to operate at 1Step MIN mode (refer to “10.7.9 Setting the Operation Modes” on page 115). Measure the offset value at low fire and compare it to the values in Table 3. If the offset value is out of range, the gas valve set screw will need to be adjusted.

If adjustment is necessary, locate the set screw as shown in Figure 12. Using an Allen or Star Wrench, turn the set screw no more than 1/4 turn clockwise to raise or counterclockwise to lower the offset value.

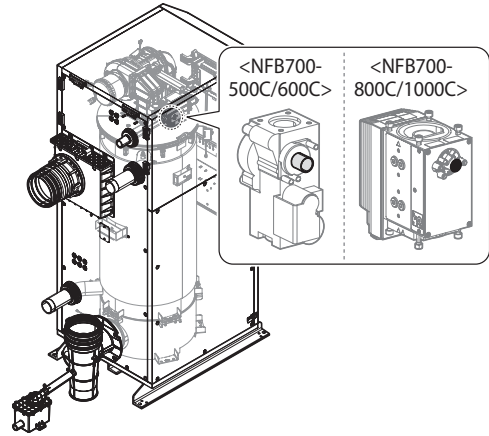

Figure 12. Set Screw Location

Note The set screw is located behind the screw-on cover. This must be removed first.

- d. At high fire, do not check the offset value and never adjust the gas valve.

! DANGER

Improper gas valve settings can cause severe personal injury, death or substantial property damage.

16. Once the CO₂ or offset values have been confirmed, apply the included conversion stickers to show that the appliance has been converted to propane gas or high altitude. Place these labels adjacent to the rating plate as shown in Figure 13.

<p>This unit has been converted to High Altitude (Natural Gas) Cet appareil a été converti au Niveau altitude (Gaz naturel)</p> <p>Orifice Size / Injecteur: Min. 10.2 mm, Remove Max. Orifice Min. 3/16 Max. 1/2 in WC</p> <p>Inlet Gas Pressure / Pression d'entrée du gaz: Min. 5.0 in WC</p> <p>Manifold Gas Pressure Pression à la tubulure d'alimentation: NFB700-800C Min. 0.01 inches WC NFB700-1000C Min. 0.01 inches WC</p> <p>BTU Input / Débit calorifique: NFB700-800C Max. 799,000 - Min. 66,000 BTU/h NFB700-1000C Max. 999,000 - Min. 66,000 BTU/h Conversion Kit No.: NAC-NH800/1000</p>	<p>This unit was converted on (day)____(month)____(year) to _____ gas with Kit No. _____ by _____</p> <p>(name and address of organization making this conversion, who accepts the responsibility for the correctness of this conversion)</p>
---	---

Figure 13. Proper Placement of Gas Conversion Labels

11.2 Wiring Diagram

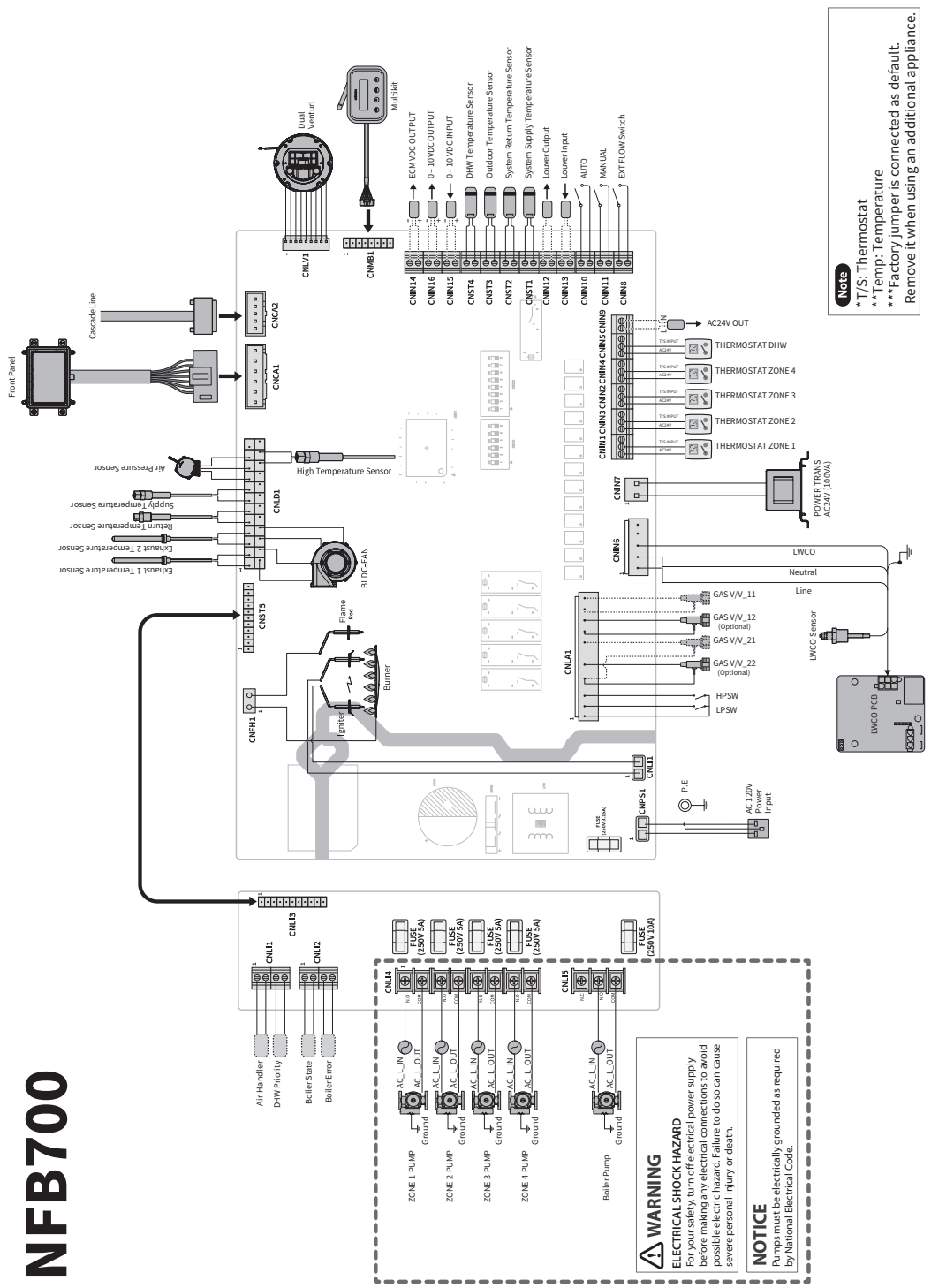

NFB700

WARNING
ELECTRICAL SHOCK HAZARD
 For your safety, turn off electrical power supply before making any electrical connections to avoid possible electric hazard. Failure to do so can cause severe personal injury or death.

NOTICE
 Pumps must be electrically grounded as required by National Electrical Code.

Note
 **T/S: Thermostat
 ***Temp: Temperature
 ****Factory jumper is connected as default.
 Remove it when using an additional appliance.

11.3 Outdoor Temperature Sensor

Outdoor Temperature Sensor

Installation

1. Pull out the sensor body from the cap.
2. Attach the body to the wall using the screws/anchors provided with the appliance.
3. Run the wires into the appliance body through the grommet opening.
4. Connect the wires to the terminal block.
5. Attach the cap to the body.

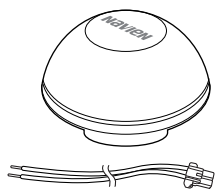

Navien Outdoor Temperature Sensor Kit

Outdoor Temperature Sensor

Installation Guidelines

- Avoid areas with temperature fluctuations by direct sunlight, and where the temperature may not be representative of true outdoor temperature.
- Best location to install the temperature sensor is on a North or Northeast side of a structure under eaves where the sensor is shielded from direct sunlight.
- Avoid placing sensor in close proximity of heat sources that may affect correct temperature sending (fans, exhausts, vents, lights).
- Avoid installing the sensor in areas where the sensor is subjected to excessive moisture.
- Use 18-gauge thermostat wire with no splices. Maximum wiring distance is 150 ft (45.7 m).
- Caution should be taken to avoid potential electromagnetic interference (EMI) by routing separately from potential sources such as line voltage wiring. When necessary, shielded cable may be used.

- Make sure wiring connections are secure before closing the cap.
- The sensor is a water resistant appliance.
- Any damage to the appliance may require the replacement of the entire component.

11.4 Outdoor Reset Control

The Outdoor Reset Control feature may be used to enhance energy efficiency while maintaining optimal heating performance. With the Outdoor Reset Control, the space heating temperature setting automatically changes according to the outdoor temperature and the current space heating system application (system load).

You can configure the Outdoor Reset Control settings on the front panel. Refer to “10.6.2 Setting the Space Heating Operation” on page 95 and “10.7.4 Setting the Operation Parameters” on page 104.

Note

The Outdoor Reset Control feature requires installation of an outdoor temperature sensor, and it only works when the boiler is running in the normal operation mode. It does not work when the boiler is running in either the Minimum (MIN) or Maximum (MAX) mode, or when the boiler’s front panel displays a fault.

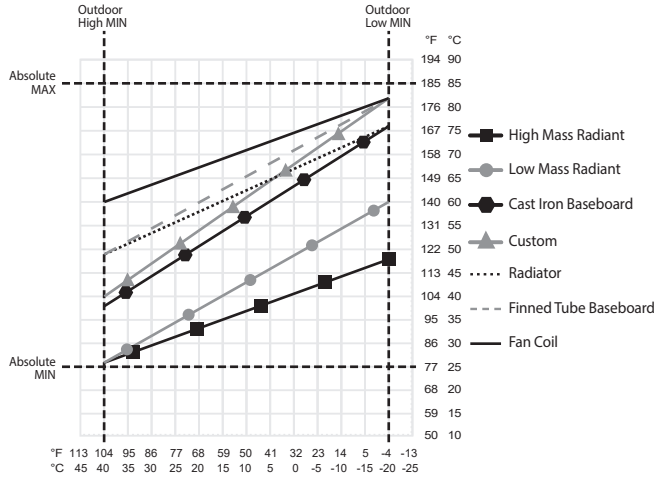

Space Heating Temperature Setting for the Outdoor Reset Control Feature

The following tables list the default space heating temperature range by system heat load and the applicable outdoor temperature ranges.

Outdoor Temperature Sensor Installation Guidelines

Heat Load	Supply Set Point Range	Return Set Point Range
Finned Tube Baseboard (default)	120-180°F (48.5-82°C)	101-147°F (38-63.5°C)
Fan Coil	140-180°F (60-82°C)	116-147°F (46.5-63.5°C)
Cast Iron Baseboard	100-170°F (37.5-76.5°C)	86-139°F (30-59°C)
Low Mass Radiant	80-140°F (26.5-60°C)	70-116°F (21-46.5°C)
High Mass Radiant	80-120°F (26.5-48.5°C)	70-101°F (21-38°C)
Radiators	120-170°F (48.5-76.5°C)	101-139°F (38-59°C)
Custom	104-180°F (40-82°C)	86-149°F (30-65°C)

Outdoor Temperature Range and Default Temperature Settings

Set Point	Range	Remarks
Outdoor Low Temperature	-4°F (-20°C) to Outdoor High Temperature Set Point - 9°F (5°C)	Default: 14°F (-10°C)
Outdoor High Temperature	Outdoor Low Temperature Set Point + 9°F (5°C) to 104°F (40°C)	Default: 70°F (21°C)

11.5 Requirements for the State of Massachusetts

NOTICE BEFORE INSTALLATION

This appliance must be installed by a licensed plumber or gas fitter in accordance with the Massachusetts Plumbing and Fuel Gas Code 248 CMR Sections 4.00 and 5.00.

IMPORTANT: In the State of Massachusetts (248 CMR 4.00 & 5.00)

For all side wall horizontally vented gas fueled equipment installed in every dwelling, building or structure used in whole or in part for residential purposes, including those owned or operated by the Commonwealth and where the side wall exhaust vent termination is less than seven (7) feet above finished grade in the area of the venting, including but not limited to decks and porches, the following requirements shall be satisfied:

1. INSTALLATION OF CARBON MONOXIDE DETECTORS. No installation or replacement of a vented gas appliance shall be permitted unless a battery powered or electrically hard wired carbon monoxide detector is present on the same floor as the appliance or on the next adjacent floor when the appliance is located in a crawl space unless the appliance is located in a detached, uninhabitable garage. For all residential dwellings, a carbon monoxide detector must also be present on each habitable level of the dwelling. These requirements shall not be deemed to waive any additional requirements imposed by M.G.L. c. 148 §26F1/2.
2. APPROVED CARBON MONOXIDE DETECTORS. Each carbon monoxide detector as required in accordance with the above provisions shall comply with NFPA 720 and be ANSI/UL 2034 listed and IAS certified.
3. SIGNAGE. Whenever any through-the-wall vent is installed less than seven feet above the finished grade, a metal or plastic identification plate shall be permanently mounted to the exterior of the building at a minimum height of eight feet above grade directly in line with the exhaust vent terminal. The sign shall read, in print size no less than 0.5 inches in size, **"GAS VENT DIRECTLY BELOW. KEEP CLEAR OF ALL OBSTRUCTIONS"**.
4. INSPECTION. The state or local gas inspector of the side wall horizontally vented gas fueled equipment shall not approve the installation unless, upon inspection, the inspector observes carbon monoxide detectors and signage installed in accordance with the provisions of 248 CMR 5.09 and 5.12.

11.6 Component Assembly Diagrams and Part Lists

11.6.1 Case Assembly and Flue Gas Vent

NFB700-500C/600C

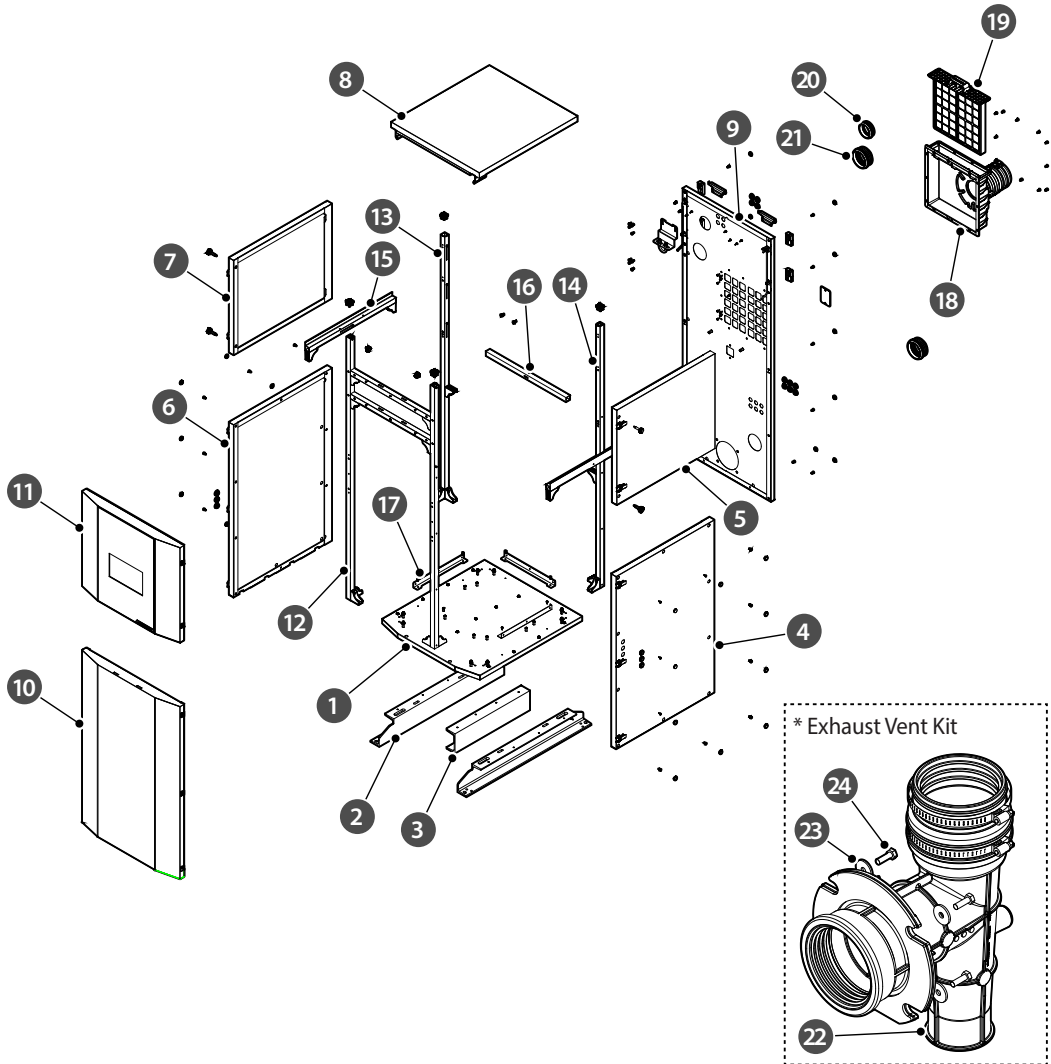

#	Description	Part #	Service Part#	Remark
1	Case (Lower)	20062013A	-	
2	Case (Leg Side)	20062059A	-	
3	Case (Leg Middle)	20071244A	-	

#	Description	Part #	Service Part#	Remark
4	Case (Lower Right)	30040923A	30040923*	
5	Case (Upper Right)	30040925A	30040925*	
6	Case (Lower Left)	30040922A	30040922*	
7	Case (Upper Left)	30040924A	30040924*	
8	Case (Upper)	30040926A	30040926*	
9	Case (Rear)	-	-	
10	Cover (Lower)	30040934A	30040934*	
11	Cover (Upper)	30040932A	30040932*	
12	Frame (Front)	30038978A	-	
13	Frame (Rear Left)	30032075A	-	
14	Frame (Rear Right)	30032076A	-	
15	Frame (Side)	30032078A	-	
16	Frame (Back)	20062046A	-	
17	Case Fix Bracket	20062056A	-	
18	Air Filter Cover	30030041A	-	
19	Air Filter	30032136A	30032136*	
20	Gas Pipe Packing	20062153A	20062153*	
21	Water Pipe Packing	20062155A	20062155*	
22	Exhaust Vent	30040176A	-	Exhaust Vent Kit: 30040177* (NFB700-500C/600C)
23	Plane Washer	20062071A	-	
24	Bolt	20006429A	-	
-	Packing	20075783A	-	
25	Panel	30036980A	30040938*	
L	Packing	20077694A	20077694*	Packing for Panel
L	Bracket	20068996A	20068996*	Bracket for Panel
26	Rubber Ring	20041970A	20041970*	
27	Screw	20072676A	20072676*	
28	Cap	20062152A	20062152*	
29	Knob	20062165A	20062165*	
30	Packing	20062150A	20062150*	
31	Hex Nut	20062466A	20062466*	
32	Bracket	30032086A	30032086*	
-	Condensated-Water Receiver	30040774A	30040774*	
-	Gas installation Assembly - Exhaust Outlet	30040177A	30040177*	
-	Gas installation Assembly - Condensate Trap	30036953A	30036953*	
-	Harness - LWCO	30033823A	30033823*	
-	Harness	30033824A	30033824*	

NFB700-800C/1000C

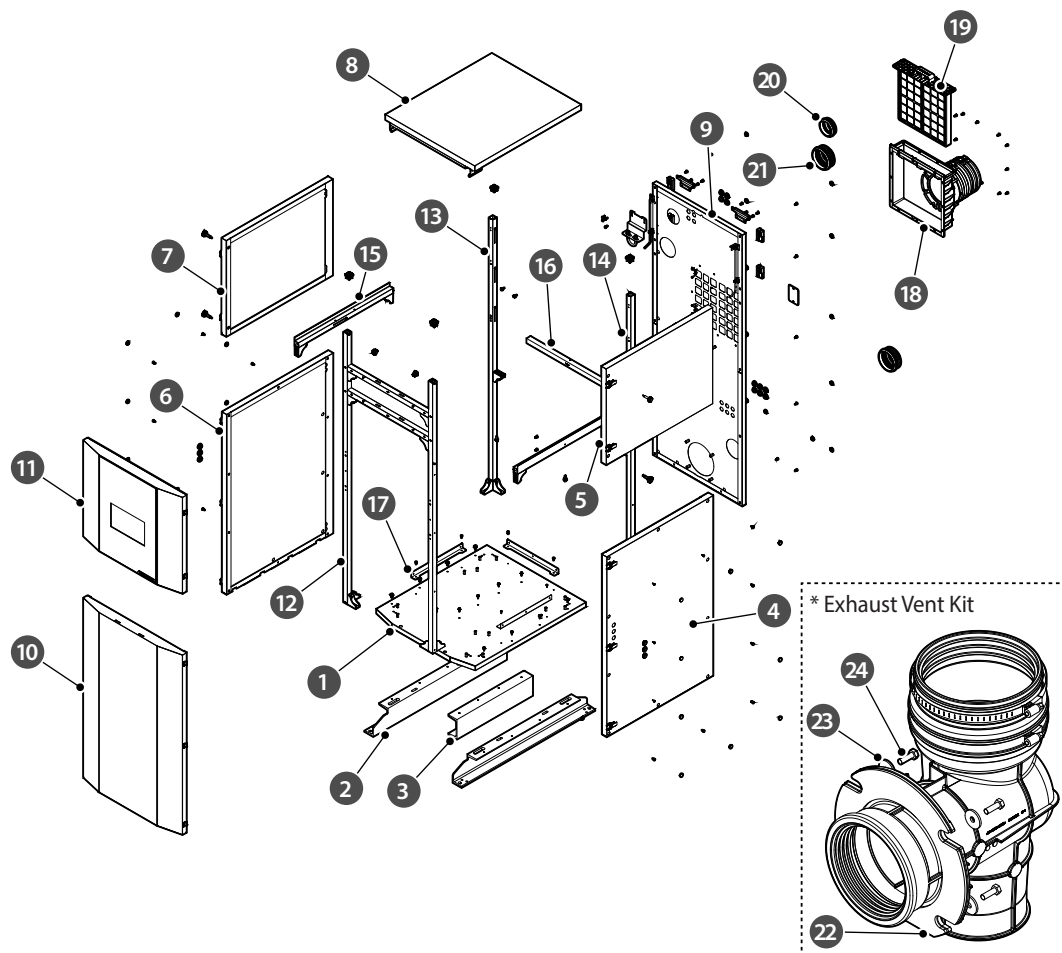

#	Description	Part #	Service Part#	Remark
1	Case (Lower)	20062012A	-	
2	Case (Leg Side)	20062058A	-	
3	Case (Leg Middle)	20071244A	-	
4	Case (Lower Right)	30040928A	30040928*	
5	Case (Upper Right)	30040930A	30040930*	
6	Case (Lower Left)	30040927A	30040927*	
7	Case (Upper Left)	30040929A	30040929*	
8	Case (Upper)	30040931A	30040931*	
9	Case (Rear)	-	-	
10	Cover (Lower)	30040933A	30040933*	

#	Description	Part #	Service Part#	Remark
11	Cover (Upper)	30040932A	30040932*	
12	Frame (Front)	30038979A	-	
13	Frame (Rear Left)	30032068A	-	
14	Frame (Rear Right)	30032069A	-	
15	Frame (Side)	30032071A	-	
16	Frame (Back)	20062046A	-	
17	Case Fix Bracket	20062056A	-	
18	Air Filter Cover	30030040A	-	
19	Air Filter	30032136A	30032136*	
20	Gas Pipe Packing	20077693A	20077693*	
21	Water Pipe Packing	20062154A	20062154*	
22	Exhaust Vent	30040162A	-	Exhaust Vent Kit: 30040163* (NFB700-800/1000C)
23	Plane Washer	20062071A	-	
24	Bolt	20006429A	-	
-	Packing	20075781A	-	
25	Panel	30036980A	30040938*	
L	Packing	20077694A	20077694*	Packing for Panel
L	Bracket	20068996A	20068996*	Bracket for Panel
L	Screw	20000035A	20000035*	Screw for Panel
26	Rubber Ring	20041970A	20041970*	
27	Screw (5x12)	20072676A	20072676*	
28	Cap	20062152A	20062152*	
29	Knob	20062165A	20062165*	
30	Packing	20062150A	20062150*	
31	Hex Nut	20062466A	20062466*	
32	Bracket	30040083A	30040083*	
-	Condensated-Water Receiver	30040775A	30040775*	
-	Gas installation Assembly - Exhaust Outlet	30040163A	30040163*	
-	Gas installation Assembly - Condensate Trap	30036953A	30036953*	
-	Harness - LWCO	30033823A	30033823*	
-	Harness	30033822A	30033822*	

11.6.2 Air Filter Assembly

NFB700-500C/600C

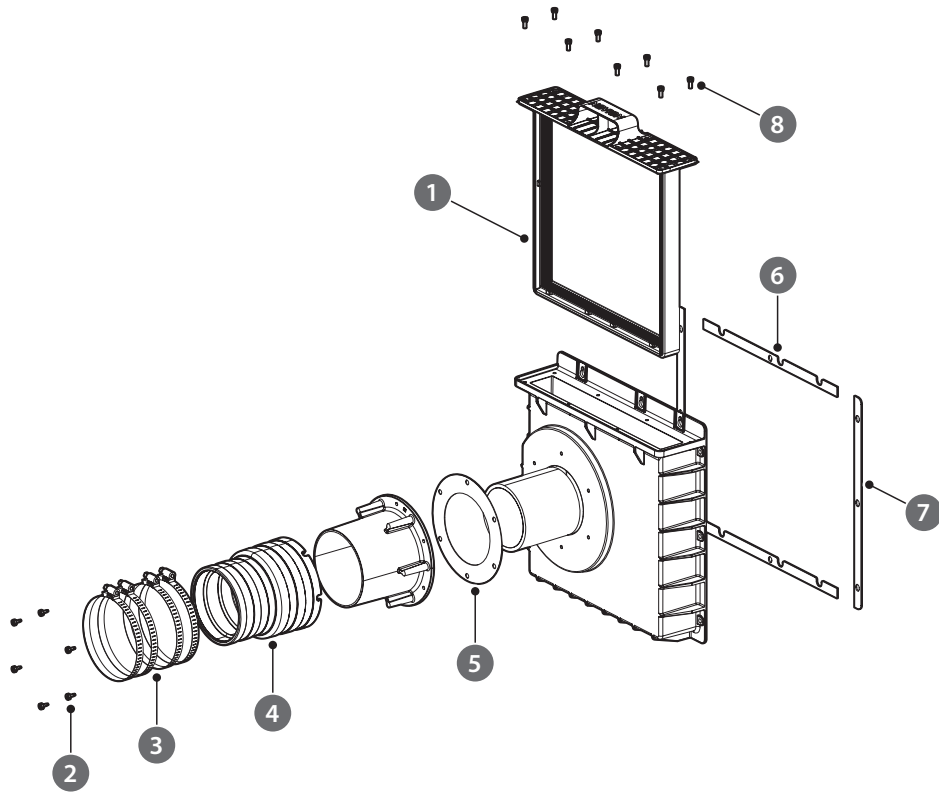

#	Description	Part #	Service Part#	Remark
1	Air Filter	30032136A	30032136*	
2	Screw	20072676A	-	
3	Clamp	20058061A	20058061*	
4	Packing	20057909A	-	
5	Packing	20058644A	-	
6	Packing	20057978A	-	
7	Packing	20057979A	-	
8	Bolt	20072675A	20072675*	

NFB700-800C/1000C

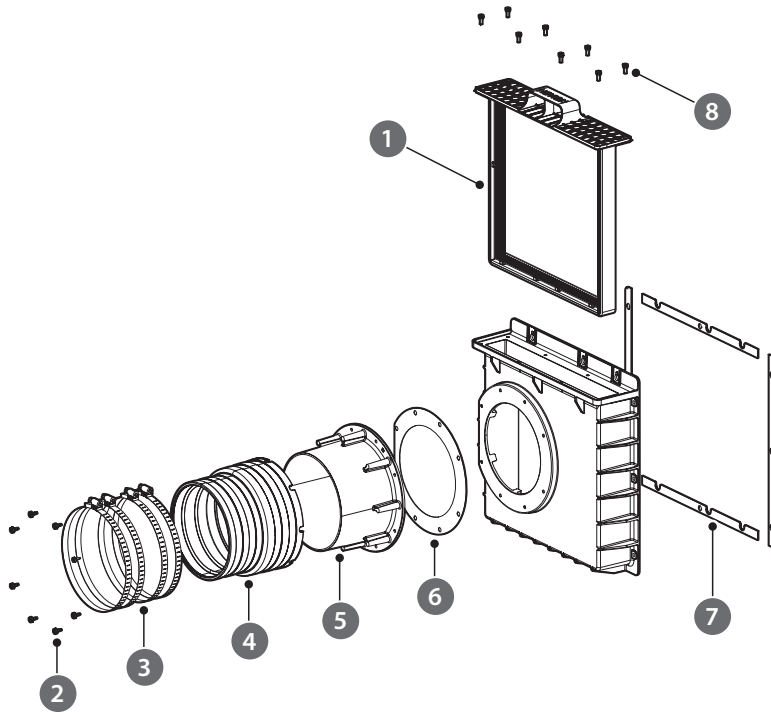

#	Description	Part #	Service Part#	Remark
1	Air Filter	30032136A	30032136*	
2	Screw	20072676A	-	
3	Clamp	20071807A	20071807*	
4	Packing	20057908A	-	
5	Flange	20062341A	-	
6	Packing	20058643A	-	
7	Packing	20057978A	-	
8	Bolt	20072675A	20072675*	

11.6.3 Controller Assembly

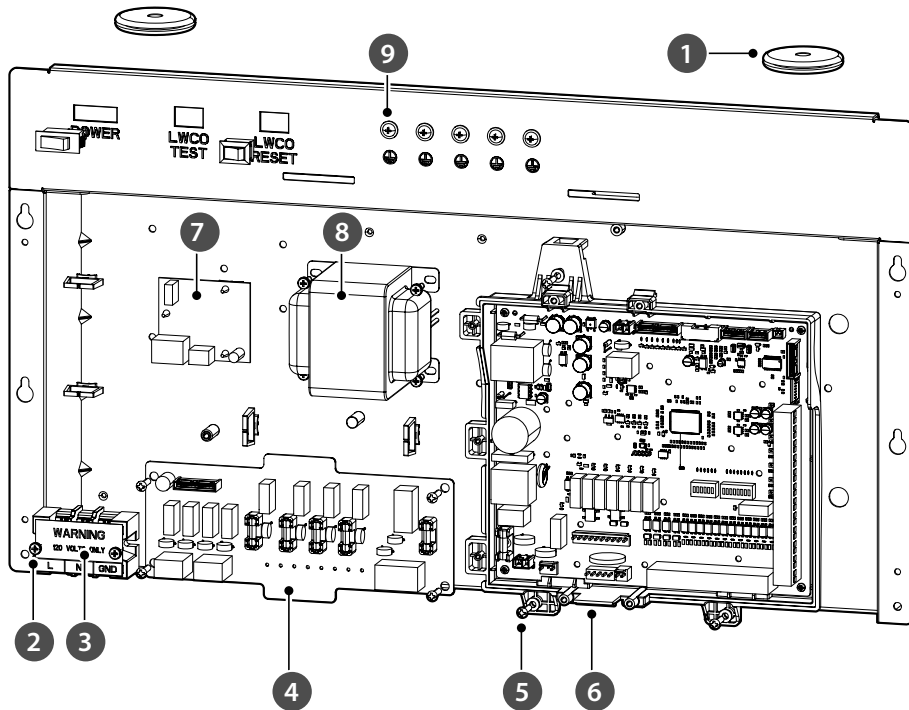

#	Description	Part #	Service Part#	Remark
1	Ring	20007458A	-	
2	Screw	20038754A	20038754*	
3	Terminal Block	30041437A	30041437*	
4	SUB-PBA	30036983A	30036983*	
5	Bolt	20009818A	20009818*	
6	Controller	30040616A	30040936*	
7	Low water Level Sensor	30032918A	30032918*	
8	Decompression Gauge	30038830A	30038830*	
9	Screw	20044834A	-	

11.6.4 Heat Exchanger and Drain Pan Assembly

NFB700-500C/600C

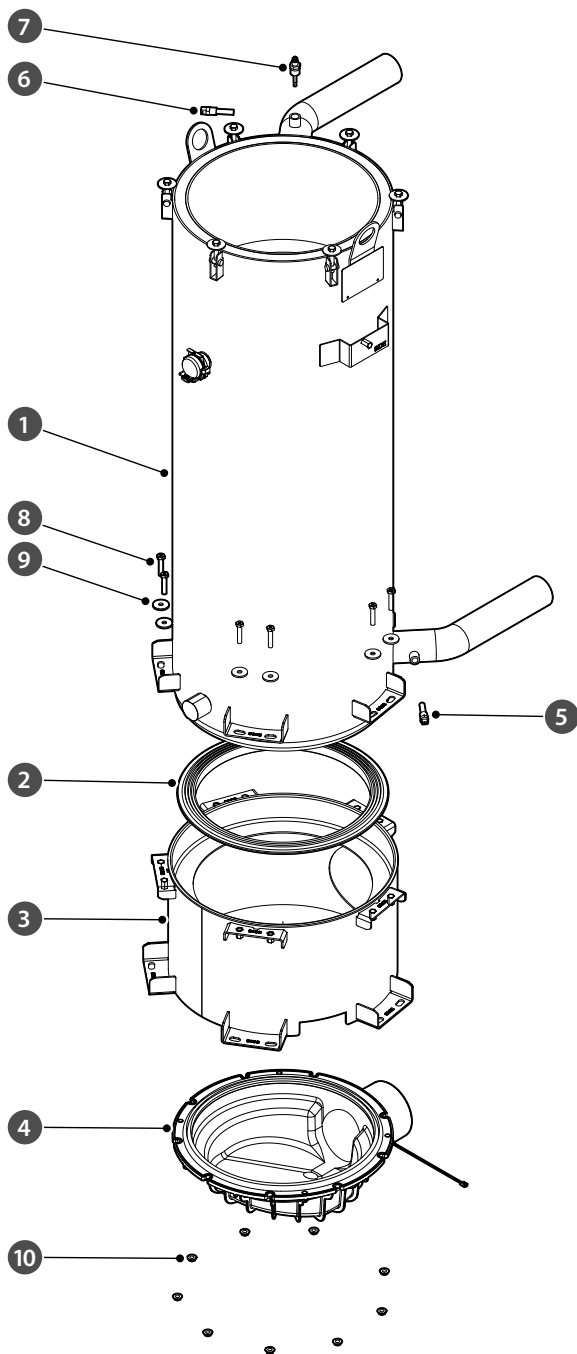

#	Description	Part #	Service Part#	Remark
1	Heat Exchanger Service KIT	30031293A	30041198*	No.1-10 Assembly
2	Drain Pan Packing	20060713A	20060713*	
3	Drain Pan Assembly	30040774A	30040774*	
4	Drain Pan Body Assembly	30040530A	-	
5	Inlet Water Temperature Sensor	30032920A	30032920*	
6	Outlet Water Temperature Sensor	30032919A	30032919*	
7	LWCO (Low water cut-off) Sensor	30032917A	30032917*	
8	Screw	20056286A	20056286*	
9	Washer	20062071A	20062071*	
10	Nut	20006600A	20006600*	
11	Exhaust Gas Thermistor	30020489A	30020489*	
12	Screw	20006535A	20006535*	
13	Clip	20040255A	20040255*	
14	Clip	20052081A	20052081*	

NFB700-800C/1000C

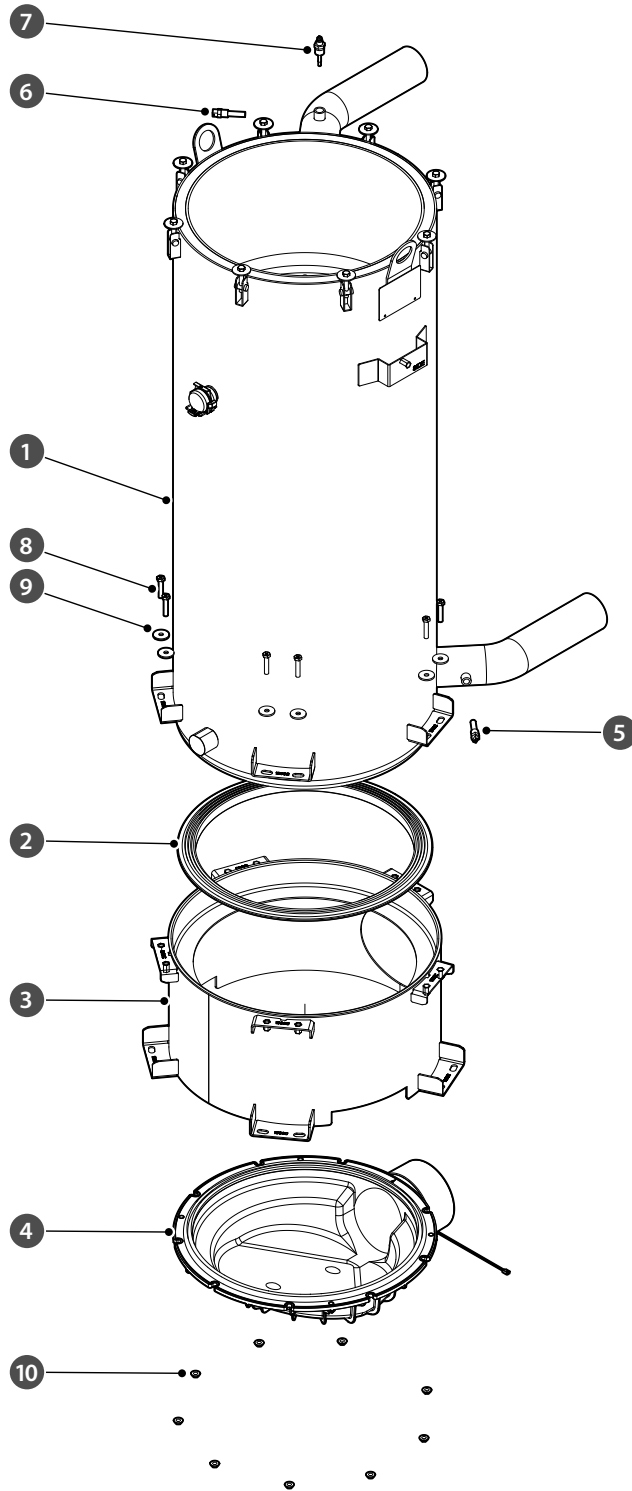

#	Description	Part #	Service Part#	Remark
1	Heat Exchanger Service KIT	30031295A	30041199*	No.1-10 Assembly
2	Drain Pan Packing	20060714A	20060714*	
3	Drain Pan Assembly	30040775A	30040775*	
4	Drain Pan Body Assembly	30040531A	-	
5	Inlet Water Temperature Sensor	30032920A	30032920*	
6	Outlet Water Temperature Sensor	30032919A	30032919*	
7	LWCO (Low water cut-off) Sensor	30032917A	30032917*	
8	Screw	20056286A	20056286*	
9	Washer	20062071A	20062071*	
10	Nut	20006600A	20006600*	
11	Exhaust Gas Thermistor	30020489A	30020489*	
12	Screw	20006535A	20006535*	
13	Clip	20040255A	20040255*	
14	Clip	20052081A	20052081*	

11.6.5 Burner Parts Assembly

NFB700-500C/600C

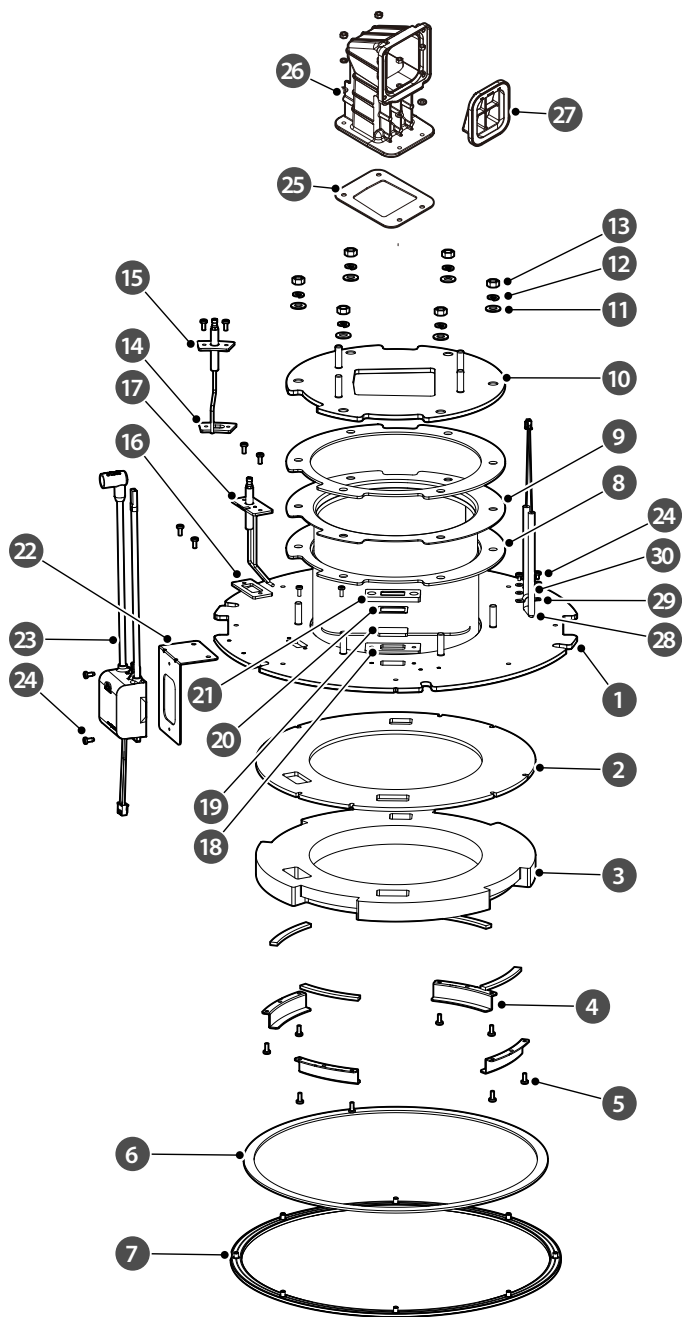

#	Description	Part #	Service Part#	Remark
1	Mix Plate Assembly	30039965A	-	
2	Chamber Insulation Paper	20072756A	-	
3	Chamber Insulation Board	20062231A	-	
4	Chamber Insulation Bracket	20078587A	20078587*	
5	Bolt	20072693A	20072693*	
6	Mix Plate Gasket (GasKet)	20062226A	30041992*	
7	Mix Plate Packing (Silicone)	20072600A	20072600*	
8	Burner Gasket (Graphite)	20062227A	30041948*	
9	Metal Fiber	30029571A	30029571*	
10	Top Plate Assembly	30033967A	-	
11	Plane Washer	20072683A	20072683*	
12	Spring Washer	20025478A	20025478*	
13	Nut	20018110A	20018110*	
14	Flame Rod Gasket (Graphite)	20045645A	30040754*	
15	Flame Rod	30032090A		
16	Igniter Gasket (Graphite)	20073711A	30040753*	
17	Igniter	30032089A		
18	Flame Inspection Window Gasket (Lower Graphite)	20062229A	30040755*	
19	Flame Inspection Window	20072757A		
20	Flame Inspection Window Gasket (Upper Graphite)	20062228A		
21	Flame Inspection Window Bracket	20062222A		
22	Ignition Transformer Bracket	20062223A	20062223*	
23	Ignition Transformer	30032916A	30032916*	
24	Screw	20038753A	20038753*	
25	Damper Gasket (Graphite)	20062252A	30041949*	
26	Damper Cover (Mix Chamber)	20062234A	-	
27	Damper Assembly	30036502A	30036502*	
28	Terminal Fuse	30020776A	30020776*	
29	Screw	20050523A	20050523*	
30	Washer	20077004A	20077004*	

NFB700-800C/1000C

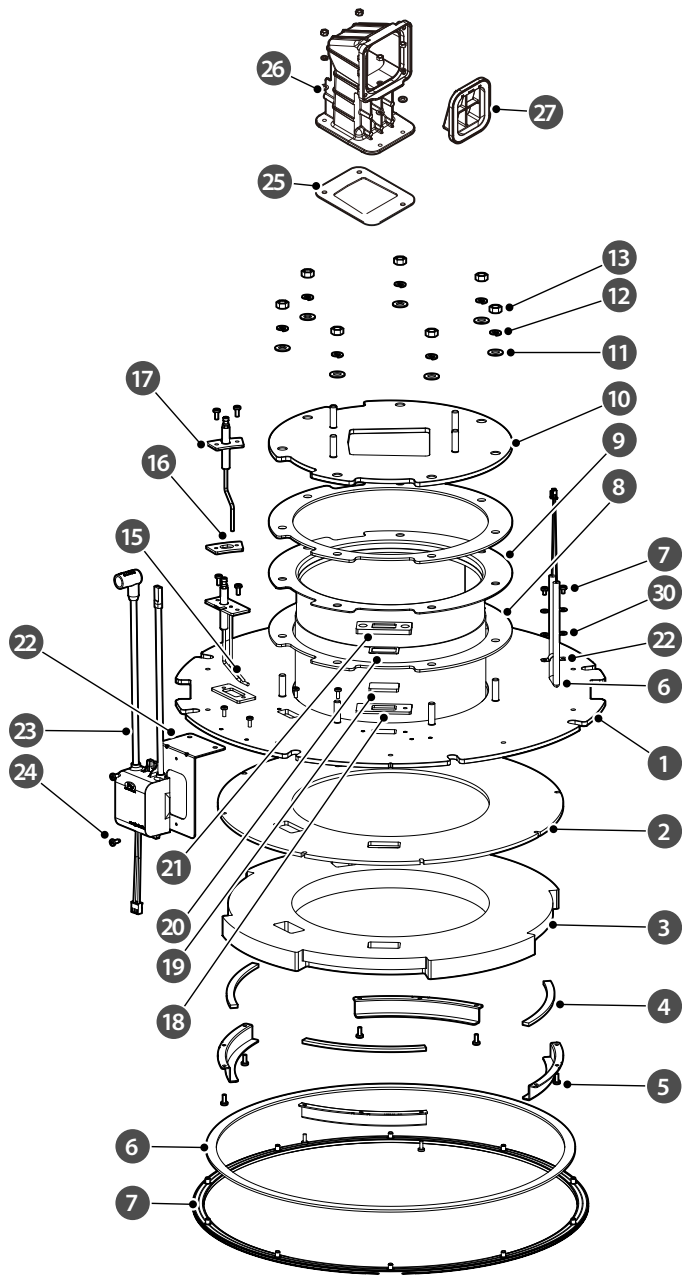

#	Description	Part #	Service Part#	Remark
1	Mix Plate Assembly	30039964A	-	
2	Chamber Insulation Paper	20072755A	-	
3	Chamber Insulation Board	20062230A	-	
4	Chamber Insulation Bracket	20078588A	20078588*	
5	Bolt	20072693A	20072693*	
6	Mix Plate Gasket (GasKet)	20062224A	30041991*	
7	Mix Plate Packing (Silicone)	20072595A	20072595*	
8	Burner Gasket (Graphite)	20062225A	30041947*	
9	Metal Fiber	30029572A	30029572*	
10	Top Plate Assembly	30039368A	-	
11	Plane Washer	20072683A	20072683*	
12	Spring Washer	20025478A	20025478*	
13	Nut	20018110A	20018110*	
14	Flame Rod Gasket (Graphite)	20045645A	30040754*	
15	Flame Rod	30032090A		
16	Igniter Gasket (Graphite)	20073711A	30040753*	
17	Igniter	30032089A		
18	Flame Inspection Window Gasket (Lower Graphite)	20062229A	30040755*	
19	Flame Inspection Window	20072757A		
20	Flame Inspection Window Gasket (Upper Graphite)	20062228A		
21	Flame Inspection Window Bracket	20062222A		
22	Ignition Transformer Bracket	20062223A	20062223*	
23	Ignition Transformer	30032916A	30032916*	
24	Screw	20038753A	20038753*	
25	Damper Gasket (Graphite)	20062252A	30041949*	
26	Damper Cover (Mix Chamber)	20062234A	-	
27	Damper Assembly	30036502A	30036502*	
28	Terminal Fuse	30020776A	30020776*	
29	Screw	20050523A	20050523*	
30	Washer	20077004A	20077004*	

11.6.6 Fan Parts Assembly

NFB700-500C

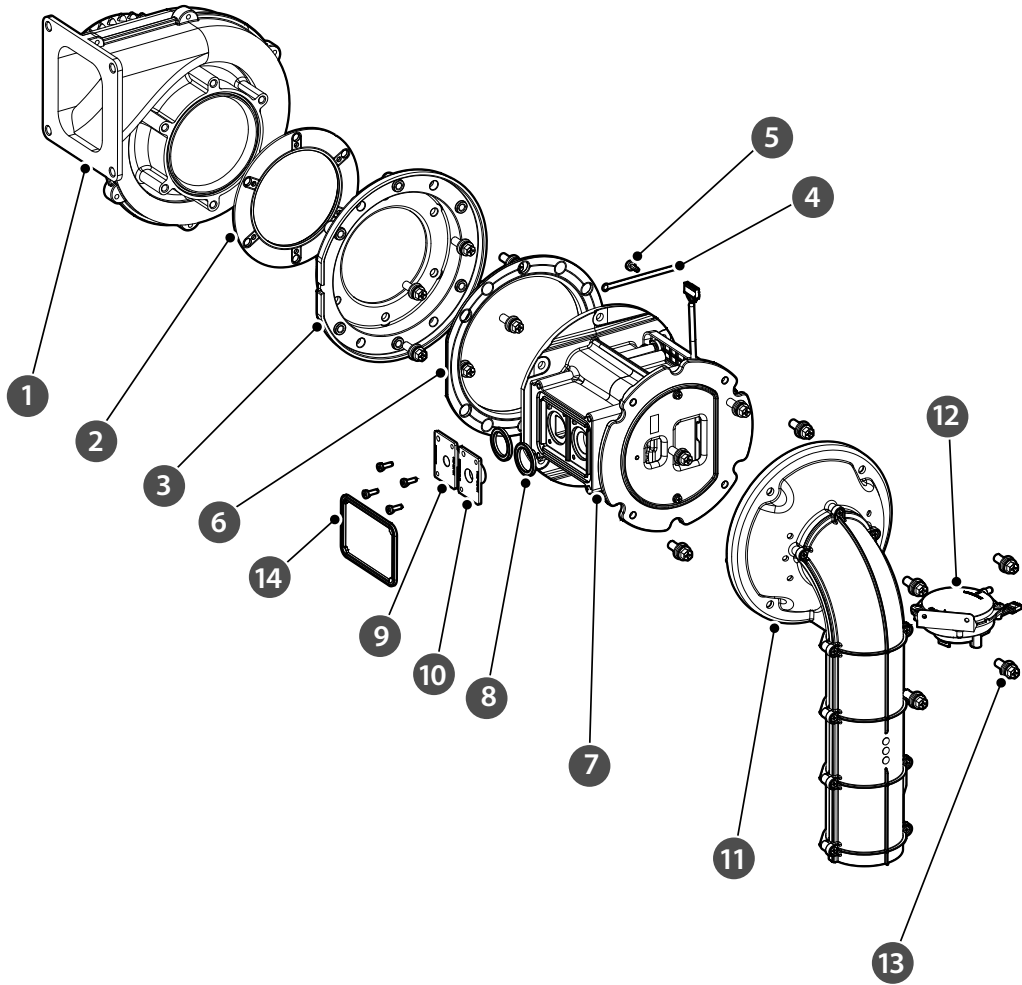

#	Description	Part #	Service Part#	Remark
1	Premix Blower	30032910A	30032910*	
2	Fan Packing	20062321A	20062321*	
3	Fan Adapter	20062236A	20062236*	
4	Retainer Coil	20003277A	-	
5	Screw (M5x12)	20072676A	20072676*	
6	Fan Adapter Packing	20062322A	20062322*	
7	Dual Venturi	30035734A	30035734*	
8	Orifice Packing	20062325A	20062325*	
9	1 Stage Gas Orifice	20072601A	20072601*	NFB700-500C/600C (NG)
10	2 Stage Gas Orifice	20072602A	20072602*	NFB700-500C/600C (NG)
11	Intake Pipe	30032119A	30032119*	
12	Air Pressure Sensor	30013265A	30013265*	
13	Bolt (M8x25)	20072673A	20072673*	
14	Gas Connection Packing	20062326A	20062326*	
-	Conversion KIT	30040446A	30040446*	NFB700-500C (LP)
		30041416A	30041416*	For High Altitude Use

NFB700-600C

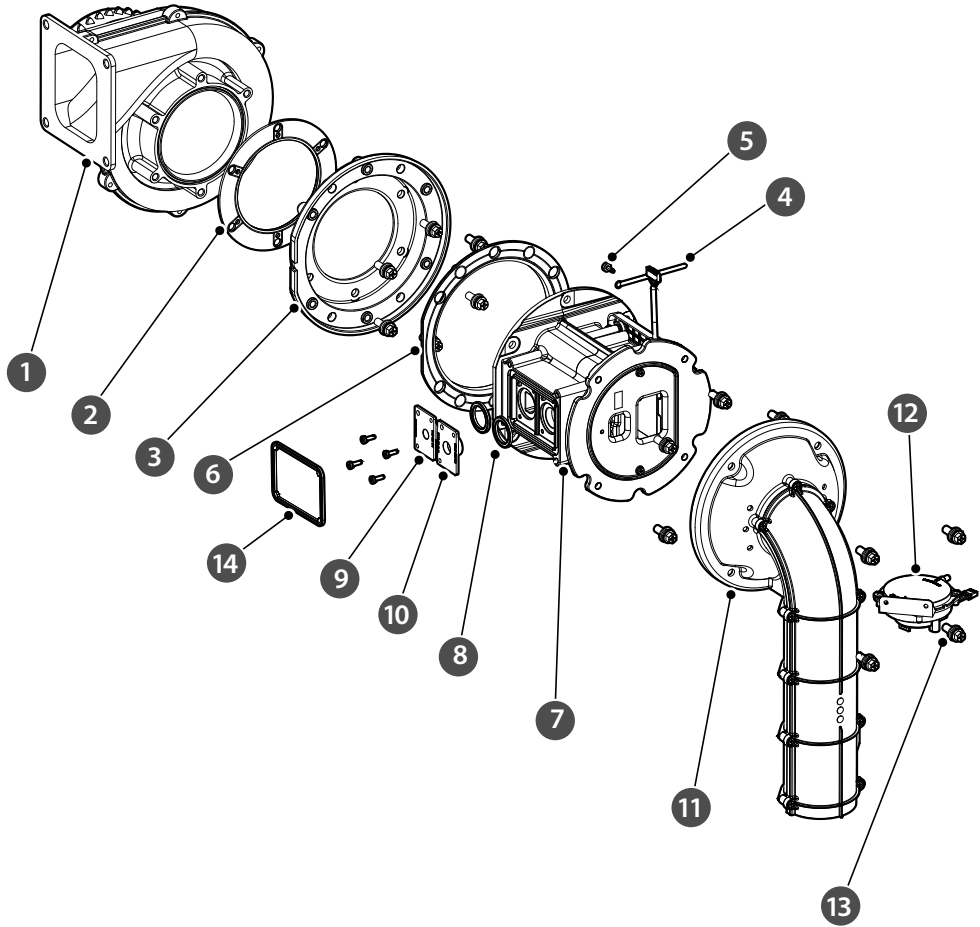

#	Description	Part #	Service Part#	Remark
1	Premix Blower	30032911A	30032911*	
2	Fan Packing	20062321A	20062321*	
3	Fan Adapter	20062236A	20062236*	
4	Retainer Coil	20003277A	-	
5	Screw (M5x12)	20072676A	20072676*	
6	Fan Adapter Packing	20062322A	20062322*	
7	Dual Venturi	30035734A	30035734*	
8	Orifice Packing	20062325A	20062325*	
9	1 Stage Gas Orifice	20072601A	20072601*	NFB700-500C/600C (LN)
10	2 Stage Gas Orifice	20072602A	20072602*	NFB700-500C/600C (LN)
11	Intake Pipe	30032119A	30032119*	
12	Air Pressure Sensor	30013265A	30013265*	
13	Bolt (M8x25)	20072673A	20072673*	
14	Gas Connection Packing	20062326A	20062326*	
-	Conversion KIT	30040028A	30040028*	NFB700-500C/600C (LP)
		30041416A	30041416*	For High Altitude Use

NFB700-800C/1000C

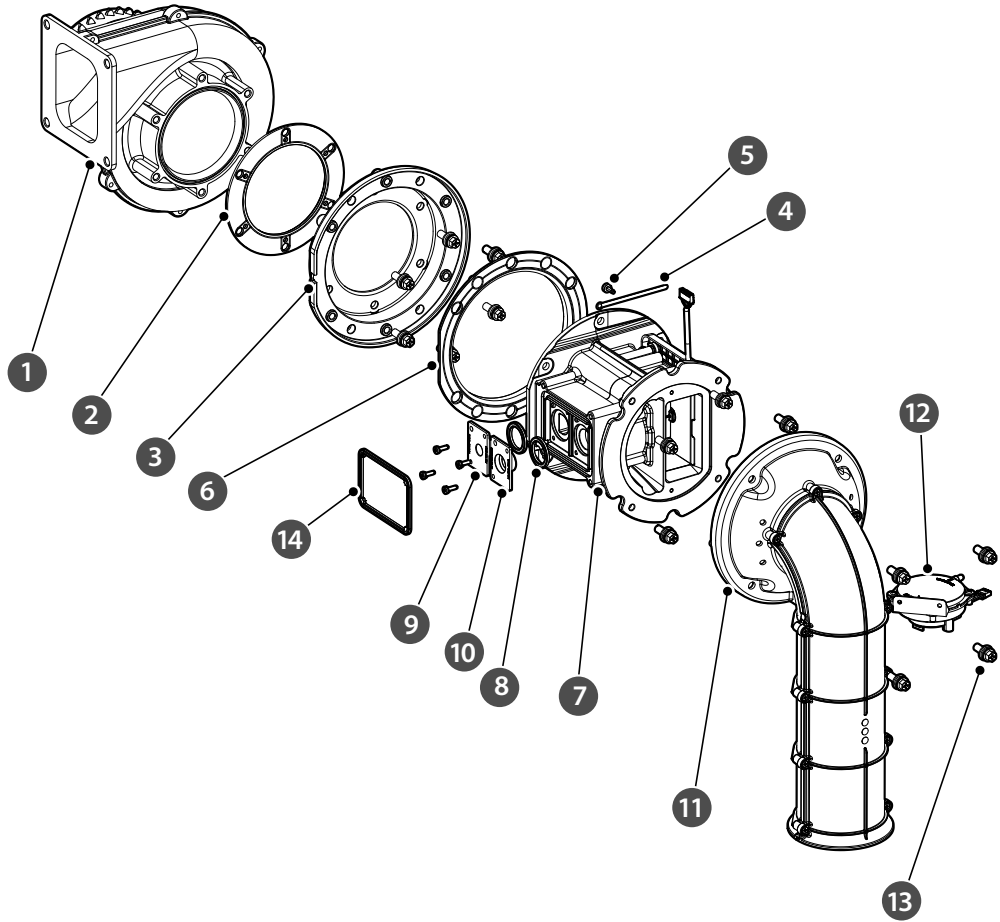

#	Description	Part #	Service Part#	Remark
1	Premix Blower	30032911A	30032911*	
2	Fan Packing	20062321A	20062321*	
3	Fan Adapter	20062236A	20062236*	
4	Retainer Coil	20003277A	-	
5	Screw (M5x12)	20072676A	20072676*	
6	Fan Adapter Packing	20062322A	20062322*	
7	Dual Venturi	30034347A	30034347*	
8	Orifice Packing	20062325A	20062325*	
9	1 Stage Gas Orifice	20066496A	20066496*	NFB700-800C/1000C (LN)
10	2 Stage Gas Orifice	20066497A	20066497*	NFB700-800C/1000C (LN)
11	Intake Pipe	30032118A	30032118*	
12	Air Pressure Sensor	30013265A	30013265*	
13	Bolt (M8x25)	20072673A	20072673*	
14	Gas Connection Packing	20062326A	20062326*	
-	Conversion KIT	30040445A	30040445*	NFB700-800C (LP)
		30040027A	30040027*	NFB700-1000C (LP)
		30041415A	30041415*	For High Altitude Use

11.6.7 Gas Pipe Parts Assembly

NFB700-500C/600C

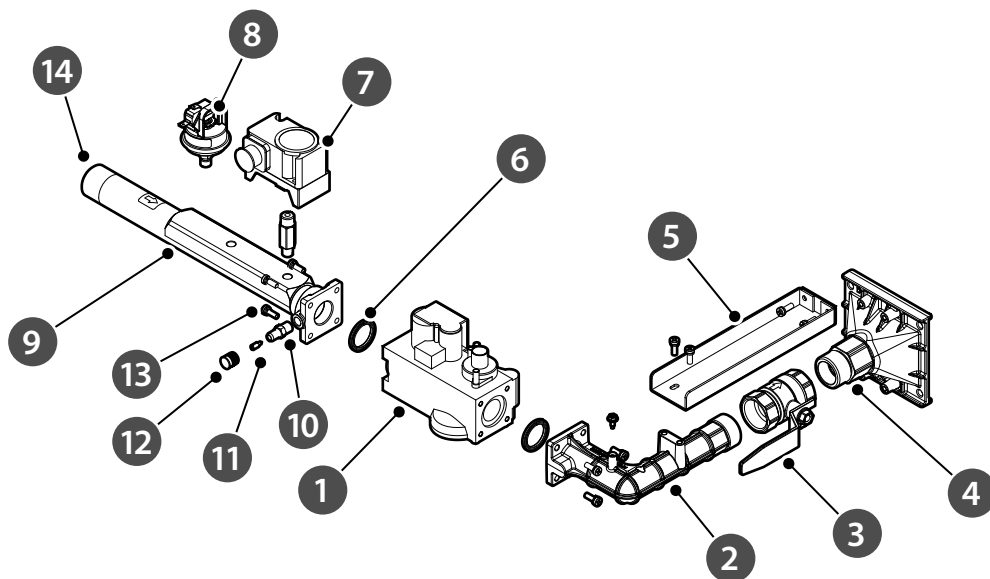

#	Description	Part #	Service Part#	Remark
1	Gas Valve	30032912A	30032912*	
2	Gas Elbow Adapter	20062332A	-	
3	Manual Shut-off Valve	30032124A	-	
4	Gas Inlet Adapter	20062330A	-	
5	Gas Elbow Adapter Bracket	20080502A	-	
6	Gas Valve Packing	20043333A	20043333*	
7	Gas Pressure Switch (Low)	30004419A	-	
8	Gas Pressure Switch (High)	30040781A	-	
9	Gas Pipe	30032126A	-	
10	Gas Pressure Measuring Nipple	20062337A	-	
11	Gas Pressure Measuring Nipple Plug	20035258A	-	
12	Gas Pressure Measuring Nipple Cap	20062338A	-	
13	Bolt	20072675A	-	
14	Gas Pipe Assembly	30032128A	30032128*	No.7-13 Assembly

NFB700-800C/1000C

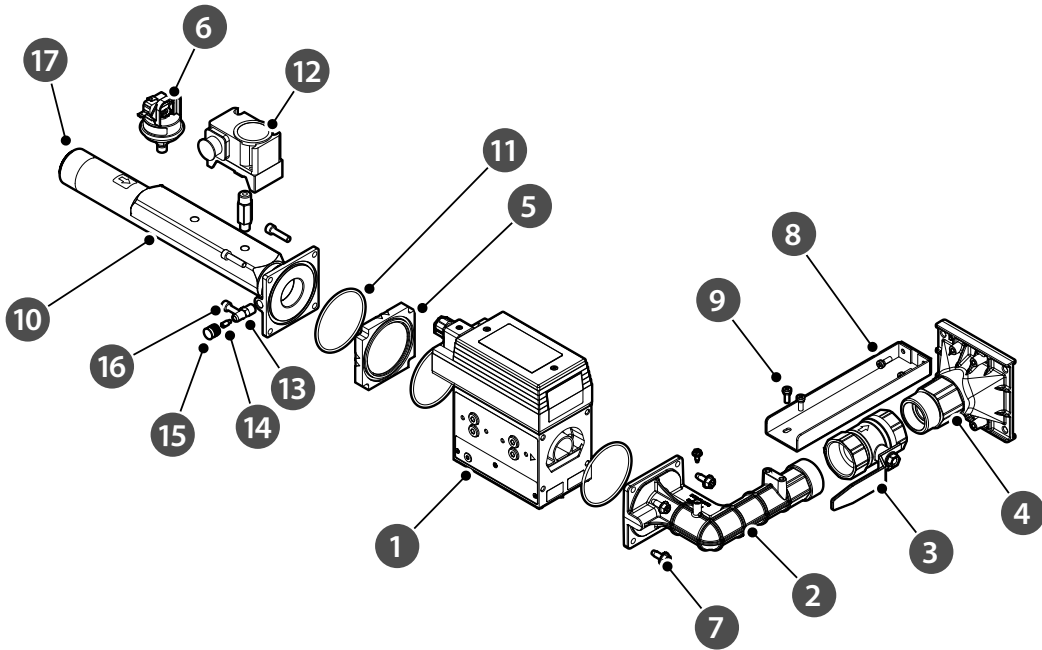

#	Description	Part #	Service Part#	Remark
1	Gas Valve	30032913A	30032913*	
2	Gas Elbow Adapter	20062331A	-	
3	Manual Shut-off Valve	30032123A	-	
4	Gas Inlet Adapter	20062329A	-	
5	Gas Valve Filter	-	-	Filter Kit
6	Gas Pressure Switch (High)	30040781A	-	
7	Bolt	20034962A	20034962*	
8	Gas Elbow Adapter Bracket	20080502A	-	Gas Valve O-ring
9	Bolt	20072675A	-	
10	Gas Pipe	30032127A	-	
11	Gas Valve O-ring	30040781A	30040912*	O-ring Kit
12	Gas Pressure Switch (Low)	30004419A	-	
13	Gas Pressure Measuring Nipple	20062337A	-	
14	Gas Pressure Measuring Nipple Plug	20035258A	-	
15	Gas Pressure Measuring Nipple Cap	20062338A	-	
16	Bolt	-	-	
17	Gas Pipe Assembly	30032127A	30032127*	No.6, 10, 12-16 Assembly

12. LIMITED WARRANTY NAVIEN, INC.

Effective Terms

This 10 year limited warranty on heat exchangers and 3 year limited warranty on parts ("Warranty") covers defects in materials or workmanship when the Navien NFB700-C Boiler ("Product") is installed by a properly licensed plumber or contractor, and installed in strict compliance with the Installation & Operations manual procedures, subject to the terms within this Warranty document. Improper installation or use will void this Warranty. This Limited Warranty does not cover any labor or material expenses incurred for removing and replacing parts or a unit supplied under this Warranty. This Warranty runs from date of installation and extends to the original purchaser and subsequent owners, but only while the Product remains at the site of the original installation. This Warranty includes a limited warranty as set forth below.

What is Covered?

This unit is intended for commercial use only. There is no warranty for residential use.

Subject to the foregoing terms, Navien will repair or replace the covered Product or any part or component that is defective in materials or workmanship for a period of three (3) years in regard to parts and ten (10) years in regard to the heat-exchanger. Navien will pay labor charges for the repair subject to Navien's prior written approval and in accordance with Navien's schedule of approved labor allowances for a period of one (1) year from the date of installation. All repair parts must be genuine Navien parts. All repairs and replacements must be performed by an individual or servicing company that is properly licensed to do the type of repair.

During the applicable warranty period, replacement of the Product or components may be authorized by Navien only. Navien does not authorize any person or company to assume for it any obligation or liability in connection with the replacement of the Product or its components. If it is determined that repair or replacement of a part, under warranty, is not possible, the Product will be replaced with a new Product having at least the same BTU capacity as the product at issue. The replacement component or product will be warranted only for the unexpired portion of the applicable warranty period for the original component or Product.

Coverage Table for Heat Exchanger and Parts Only	
Commercial	
Heat Exchanger	10 Year
Parts	3 Years

How do I get service?

You must contact the original installer of your Product. Your installer will need to contact Navien to report the issue. If the original installer cannot be identified or you no longer choose to use that service provider, you may choose any service provider who is properly licensed to complete the necessary repair. The installer and/or service provider must comply with Navien's warranty service and return policy procedures as available on Navien's website including contacting Navien's Technical Support Department at (800) 519-8794, option 2, prior to commencing any service.

Proof of the date of installation must be provided to Navien. At Navien's request, the defective Product or part must be returned to Navien. When the Product is installed in new construction, the date of installation shall be established as the date upon which the end-user takes title to the real property. If proof of the installation date is unavailable, then six months after the date of manufacture will be used.

Additional terms and conditions are continued on the reverse side.



Customer Name :	
Customer Address :	
Telephone :	Fax :
Email :	
Installer Name :	License No :
Installer Address :	
Place of Purchase :	
Model No :	
Serial No :	
Date of Purchase :	



Navien, Inc.

20 Goodyear,
Irvine, CA 92618
Tel : 1-800-519-8794
Fax : 949-420-0430
www.navieninc.com

For instant warranty registration, please register your product online at navieninc.com

What is not covered?

Navien's Limited Warranty does not cover any labor costs associated with removing, repairing, and/or replacing any parts of the unit, and/or replacement of the unit, including but not limited to:

- Troubleshooting and diagnostics charges,
- Travel and/or service truck charges,
- Shipping or freight charges, and
- Fees from third parties such as wholesalers.

Navien's Limited Warranty shall be void in the event of an occurrence of any of the following;

- Improper installation, including but not limited to, installation in violation of applicable rules, laws or building codes, inadequate water quality, condensate damage, improper venting, incorrect gas type, water pressure, absence of a drain pan, improper conversion from Natural Gas source to Propane, reinstallation at another location, etc.
- Accident, abuse or misuse including but not limited to installation for non-recommended uses, failure to follow or comply with the User's Operational Manual, etc.
- Improper maintenance including but not limited to, scale buildup, vent blockage, failure to maintain, etc.
- Modification, alteration, addition of non-approved components, or misapplication of the Product in any manner.
- Any damage caused by local adverse conditions including but not limited to water quality, hard water deposits, lime or mineral buildup, operating in corrosive atmospheric elements, alterations in smell or taste of water that have an adverse reaction on the unit, etc.
- Damage or problems caused by gas flow issues, electrical surges, flooding, fire, freezing, abnormal external temperature, force majeure, riot, act of war, or any acts of God.
- Performance problems caused by improper sizing of the boiler, the gas supply line, the venting connection, combustion air openings, electric service voltage, wiring, fusing or any other components, parts or specifications.
- Vibration and noise unless caused by a defect in materials or workmanship. Any other causes other than defects in materials or workmanship.
- Operating the Product at water temperature outside the factory calibrated temperature limits and/or exceeding the maximum setting of the high limit control.

- Subjecting the heat exchanger to pressures or firing rates greater or lesser than those shown on the rating plate or removal of or alteration to the rating plate.
- Installation at any location outside the United States or Canada.
- Improper conversion from natural gas to liquid propane gas or liquid propane gas to natural gas or attempt to operate with a type of gas not specified for the boiler.
- Accidental or intentional damage.

There is no warranty on any Product purchased through the internet or from any installer that obtained the Product from a supplier or distributor not authorized by Navien.

Warranty Limitations

EXCEPT AS EXPRESSLY PROVIDED HEREIN, THERE ARE NO OTHER WARRANTIES, EXPRESSED OR IMPLIED, INCLUDING, BUT NOT LIMITED TO WARRANTIES OR MERCHANTABILITY OR FITNESS FOR A PARTICULAR PURPOSE, WHICH EXTEND BEYOND THE DESCRIPTION OF THE WARRANTY HEREIN AND FURTHER NAVIEN SHALL NOT BE LIABLE FOR INDIRECT, INCIDENTAL, SPECIAL, CONSEQUENTIAL, PUNITIVE OR OTHER SIMILAR DAMAGES THAT MAY ARISE, INCLUDING LOST PROFITS, DAMAGE TO A PERSON OR PROPERTY, LOSS OF USE, INCONVENIENCE, OR LIABILITY ARISING FROM IMPROPER INSTALLATION, SERVICE OR USE OF THE PRODUCT. ANY IMPLIED WARRANTIES OF MERCHANTABILITY AND FITNESS ARISING UNDER STATE LAW ARE LIMITED IN DURATION TO THE PERIOD OF COVERAGE PROVIDED BY THIS WARRANTY, UNLESS THE PERIOD PROVIDED BY STATE LAW IS LESS.

No one is authorized to make any other warranties on behalf of Navien.

Some states do not allow the exclusion or limitation of incidental or consequential damages, or how long an implied warranty lasts, so the above limitation may not apply to you.

This Limited Warranty gives you specific legal rights and you may also have other rights which vary from state to state.

Rev. 14/01/25

Retain this document for future reference.



For instant warranty registration, please register your product online at navieninc.com

Notes

Installation & Operation Manual

NFB700 Commercial Condensing Boilers

Getting Service

If your boiler requires service, you have several options for getting service:

- Contact Technical Support at 1-800-519-8794 or on the website: www.navienc.com.
- For warranty service, always contact Technical Support first.
- Contact the technician or professional who installed your boiler.
- Contact a licensed professional for the affected system (for example, a plumber or electrician).

When you contact Technical Support, please have the following information at hand:

- Model number
- Serial number
- Date purchased
- Installation location and type
- Error code, if any appears on the front panel display.

Version: 1.0 (January, 2026)



800.519.8794 | www.navienc.com
20 Goodyear Irvine, CA 92618