



NFB700-C Commercial Condensing Boilers

Submittal

Model NFB-500C (499,000 BTU/h)

Model NFB-600C (599,000 BTU/h)

Model NFB-800C (799,000 BTU/h)

Model NFB1000C (999,000 BTU/h)

Job Name: _____

Location: _____

Engineer: _____

Wholesaler: _____

Sales Rep: _____

Contractor: _____

Model: _____ Gas Type (NG/LP): _____ Input (BTU/h): _____ Output (BTU/h): _____

Notes: _____

Boiler Standard Features

- Stainless Steel Fire Tube Heat Exchanger, ASME "H"
- 97.5% Thermal Efficiency
- Fully Modulating Burner with up to 15:1 Turndown Ratio
- Low NOx (<20ppm)
- 160 PSI ASME Max Pressure
- 50 PSI ASME Relief Valve
- Direct Spark Ignition
- Variable Speed Blower
- Intake Air Filter
- Dual Venturi Mixing System
- Negative Pressure Gas Valve
- LP Gas Conversion Kit
- High Elevation Conversion Kit
- Built-In WiFi Control
- Outdoor Temperature Sensor
- Universal Temperature Sensor and Well Kit
- Condensate Trap
- Flue Gas Vent and Support Kit
- Air Vent

Venting

- Vertical or Horizontal Direct Venting, Non-Direct Venting
- NFB-500C & NFB600C Vent: 4 in. up to 150 ft.
- NFB-800C & NFB1000C Vent: 6 in. up to 150 ft.
- Vent Materials: PVC, CPVC, approved PP or SS
- Common Venting up to 4 boilers

Boiler Optional Accessories

- Condensate Neutralizer Kit
- Zone Controllers
- Ready-Link Cascade Cable
- 75 PSI Pressure Relief Valve
- 150 PSI Pressure Relief Valve
- Common Vent Backflow Dampers: 4" and 6"
- BMS Gateway Module: Modbus/BACnet, LonWorks

Controls

- 10 in. Touch Screen Color Display
- Start-Up Wizard
- LWCO with Manual Reset
- High Temperature Limit Control with Manual Reset
- CSA, UL Certified Controls
- Freeze Protection
- Outdoor Reset
- Warm Weather Shutdown
- Air Handler Interface
- 5 Circulator Outputs
- Cascading up to 8 boilers
- Remote Access via Navi-Link Mobile Application

Warranties

- 10 year. Commercial Heat Exchanger Warranty
- 3 year Commercial Parts Warranty

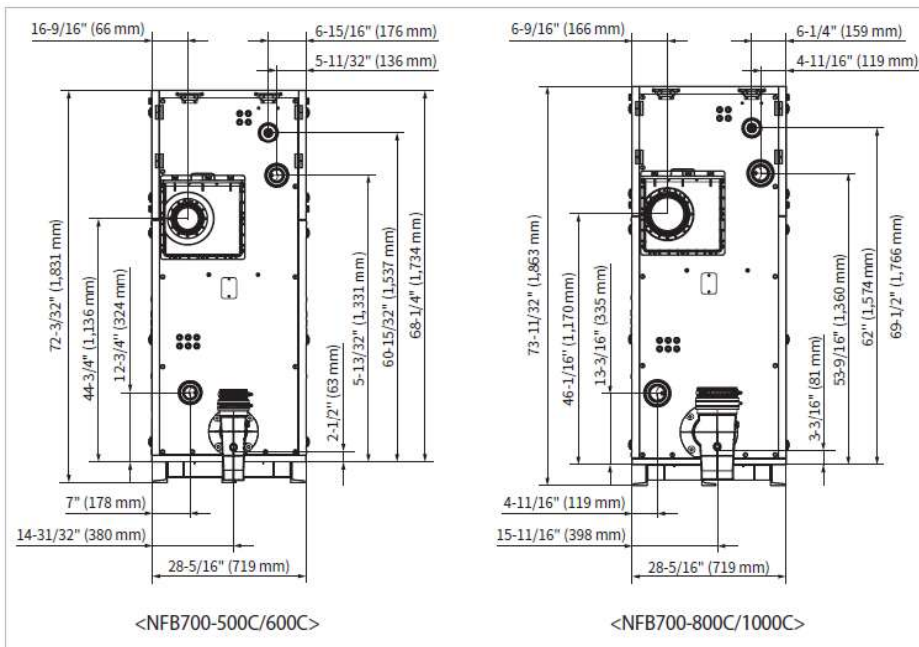
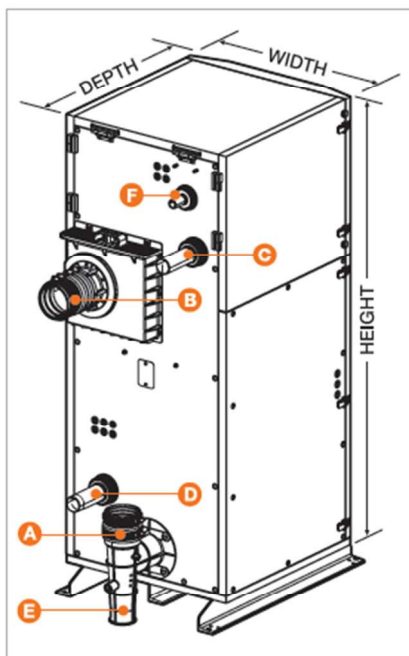

Description	NFB700-500C NFB700-600C	NFB700-800C NFB700-1000C
A Exhaust gas vent	4 in	6 in
B Air intake	4 in	6 in
C Heating supply	2 in	2.5 in
D Heating return	2 in	2.5 in
E Condensate outlet	1 in	1 in
F Gas connection	1 in	1.25 in

Navien Commercial Condensing Boiler Space Heating Ratings						Other Specifications		
Model Number ¹	Heating Input (MBH)		Gross Output ² (MBH)	Net AHRI Rating Water ³ (MBH)	Thermal Efficiency ² (%)	Boiler Water Content (Gallons)	Water Pressure	Water Connection Size Min. Max. (Supply, Return)
	Min.	Max.						
NFB700-500C	40	499	486	423	97.5	26.5	12-160 psi	2 in NPT
NFB700-600C	40	599	584	508	97.5			
NFB700-800C	66	799	779	677	97.5	37.0		2½ in NPT
NFB700-1000C	66	999	974	847	97.5			