



57098

# Installation Manual

## NWP500 Electric Heat Pump Water Heaters

**Model** | NWP500-50  
NWP500-65  
NWP500-80



- Conforms to UL STD 60335-1, 60335-2-40 and 174  
- Certified to CSA STD C22.2 # 60335-1, 60335-2-40 and 110

**FC** Contains :  
FCC ID : P53-EMC3290  
IC ID : 23507-EMC3290



ALWAYS read and follow this manual completely before using the water heater. Save for future reference.

Tested and Certified to NSF/ANSI 372 for lead free\* compliance.

\* The wetted surface of this product contacted by consumable water contains less than one quarter of one percent (0.25%) of lead by weight.

### **⚠ WARNING**

- Improper installation, operation, or service can damage the water heater, your home, and other property and can create hazards such as fire, burns, electric shock, and explosion, which can result in serious injury or death.
- Read this manual and the water heater's label before installing, operating, or servicing. If you have difficulty following the instructions or are not sure that you can safely and properly perform this work yourself, contact a qualified installer or service organization for installation and servicing.
- Do not destroy this manual; read it carefully and keep it in a safe place for future reference.

# FCC and IC STATEMENT



This equipment has been tested and found to comply with the limits for a Class B digital device, pursuant to part 15 of the FCC Rules. These limits are designed to provide reasonable protection against harmful interference in a residential installation. This equipment generates, uses and can radiate radio frequency energy and, if not installed and used in accordance with the instructions, may cause harmful interference to radio communications. However, there is no guarantee that interference will not occur in a particular installation. If this equipment does cause harmful interference to radio or television reception, which can be determined by turning the equipment off and on, the user is encouraged to try to correct the interference by one or more of the following measures:

- Reorient, or relocate, the receiving antenna.
- Increase the distance between the equipment and receiver.
- Connect the equipment into an outlet on a circuit different from that to which the receiver is connected.
- Consult the dealer or an experienced radio/TV technician for help.

## **FCC Part 15 Related Statement - Keep for Liability Purposes**

This device complies with part 15 of the FCC Rules. Operation is subject to the following two conditions:

- (1) This device may not cause harmful interference.
- (2) This device must accept any interference received, including interference that may cause undesired operation.

Any changes or modifications in construction of this device which are not expressly approved by the party responsible for compliance could void the user's authority to operate the equipment.

### **⚠ WARNING**

The manufacturer is not responsible for any radio or TV interference caused by unauthorized modifications to this equipment. Such modifications could void the user's authority to operate the equipment.

## **FCC RF Radiation Exposure Statement**

This equipment complies with FCC RF Radiation exposure limits set forth for an uncontrolled environment. This device and its antenna must not be co-located or operating in conjunction with any other antenna or transmitter.

"To comply with FCC FR exposure compliance requirements, this grant is applicable to only Mobile Configurations. The antennas used for this transmitter must be installed to provide a separation distance of at least 8 inches (20 cm) from all persons and must not be co-located or operating in conjunction with any other antenna or transmitter."

FCC IDENTIFIER: P53-EMC3290

## **Canadian Compliance Statement**

This device complies with industry Canada license-exempt RSS standard(s). Operation is subject to the following two conditions:

- (1) This device may not cause interference.
- (2) This device must accept any interference, including interference that may cause undesired operation of the device.

To reduce potential radio interference to other users, the antenna type and its gain should be so chosen that the equivalent isotropic radiated power (e.i.r.p) is not more than that permitted for successful communications.

## **Industry Canada Statement**

Complies with the Canadian ICES-003 Class B specifications.

This device complies with RSS 210 of Industry Canada. This Class B device meets all the requirements of the Canadian interference-causing equipment regulations.

This radio transmitter (IC: 23507-EMC3290) has been approved by Industry Canada to operate with the antenna types listed below with the maximum permissible gain and required antenna impedance for each antenna type indicated. Antenna types not included in this list, having a gain greater than the maximum gain indicated for that type, are strictly prohibited for use with this device.

# Contents

<b>1. Important Safety Information</b>	<b>4</b>	5.10 Setting the Recirculation Mode	53
<b>2. About the Water Heater</b>	<b>7</b>	5.11 Configuring the Installer Settings	55
2.1 Included Items	7	5.12 Diagnosing the Water Heater	58
2.2 Accessories	7	5.13 Setting the Display Options	59
2.3 Specifications	8	5.14 Initializing All Parameter Settings (Factory Reset)	60
2.4 The Front Panel	9	5.15 Connecting the Navilink App with the Water Heater	60
2.5 Components	11	5.16 Water Heater Protection Features	61
2.6 Dimensions	12	5.17 Component Test Features	62
2.7 Rating Plate	15	5.18 Additional Features	62
<b>3. Installing the Water Heater</b>	<b>16</b>	<b>6. Maintaining the Water Heater</b>	<b>64</b>
3.1 Installation Diagram	16	6.1 Maintaining the T&P Relief Valve	64
3.2 Considerations for Proper Installation	17	6.2 Cleaning the Air Filter	65
3.3 Choosing an Installation Location	18	6.3 Inspecting the Condensate Drain	65
3.4 Connecting Water Pipes	22	6.4 Draining and Flushing the Water Heater	66
3.5 Ducting Requirements	26	6.5 Maintenance for Extended Periods of Inactivity	66
3.6 Connecting the Power Supply	28	6.6 Replacing the Heating Element	66
3.7 Insulation Blanket	30	6.7 Replacing the Energy Cut Off (ECO) Switch	68
3.8 Removing the Battery Protective Film	30	6.8 Replacing the Battery on the Front Panel	69
3.9 Demand Response (CTA-2045) Installations	30	6.9 Setting the DIP Switches	69
3.10 Installing the Thermostatic Mixing Valve (Optional Accessory)	31	6.10 Installing Emergency Part Kit for Repairs	70
3.11 Installing the Shut-off Valve (Optional Accessory)	31	<b>7. Troubleshooting</b>	<b>71</b>
3.12 Installing the Navien Leak Detection System (Optional Accessory)	32	7.1 Solving Basic Problems	71
3.13 Using the Navien Recirculation Pump (Optional Accessory)	34	7.2 Understanding Error Codes	73
<b>4. Installation Check List</b>	<b>42</b>	<b>8. Appendixes</b>	<b>76</b>
<b>5. Operating the Water Heater</b>	<b>44</b>	8.1 Wiring Diagram	76
5.1 Turning the Water Heater On or Off	44	8.2 Component Assembly Diagrams and Parts Lists	77
5.2 Start-Up Wizard	45		
5.3 Selecting the Operation Mode & Adjusting Water Temperature	45		
5.4 About Operating Modes	46		
5.5 Setting Operation Schedules and Configuring Communication Settings	47		
5.6 Viewing Status Information	49		
5.7 Viewing System Information	51		
5.8 Viewing Error History	52		
5.9 Viewing Other System Operation Information	53		

## LIMITED WARRANTY NAVIEN, INC.

Product Installation Information	
Model Number	
Date Purchased	
Serial Number	

# 1. Important Safety Information



The following Safety Alert Symbols are used in this manual. They are used to alert you to potential personal injury hazards. Obey all safety messages that follow this symbol to avoid possible serious injury or death. This Safety Alert Symbol precedes any safety message about risk of personal injury. It may also be accompanied by one of the following signal words.

If the information in these instructions is not followed exactly, a fire or explosion may result, causing property damage, personal injury or death.

## DANGER

Indicates a hazardous situation that if not avoided will result in death or serious injury.

## WARNING

Indicates a hazardous situation that if not avoided could result in death or serious injury.

## CAUTION

Indicates a potentially hazardous situation that if not avoided could result in minor or moderate injury.

## **NOTICE**

Indicates information considered important but not hazard-related (such as property damage).

## DANGER

### Electric Shock Hazards



- Contact with electrical parts in the junction box, behind access doors, and inside the top shroud can result in severe injury or death due to electric shock.
- Disconnect power by opening the circuit breaker or removing the fuses before installation or servicing.
- Use a non-contact circuit tester to confirm that the power is off before working on or near any electrical parts.
- Replace the junction box cover and access doors after servicing.
- When making electrical connections for your water heater, follow the Wiring Diagram carefully to ensure safety and proper operation. Use 10-gauge solid copper wire for all connections to handle the electrical load effectively. It is also important to use a UL-listed or CSA-approved strain relief to secure the wires and prevent them from being pulled or damaged. Finally, connect the ground wire securely to the green ground screw to ensure proper grounding and reduce the risk of electrical shock.

## **⚠ DANGER**

### Scald Hazards

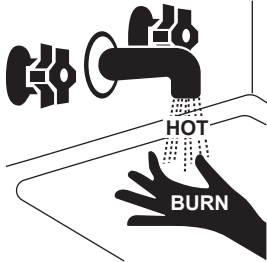

Water temperatures over 125°F (52°C) can cause severe burns instantly or death from scalds. Children, disabled and elderly are at highest risk of being scalded. Feel water with your elbow before bathing or showering. Temperature limiting valves are available, contact a licensed plumber for more information.

#### To prevent burns:

- Set the operating temperature to the lowest level that still meets your needs.
- If your household has children or elderly or disabled residents, consider using a lower temperature setting.
- Check local codes for maximum water temperature setting allowed when used in nursing homes, schools, day care centers and other public applications.
- Do not leave children, the elderly, or disabled persons unsupervised.
- Do not allow small children to play unsupervised in the bathroom.
- Do not allow anyone to change the water temperature while hot water is running.
- Read all the instructions in this manual carefully before changing the temperature setting.
- Feel the water before using it on children, the elderly, or the disabled.
- If it is necessary to set the water temperature above 125°F (52°C), consider installing a thermostatically-controlled mixing valve or temperature-limiting valve. Contact a licensed plumber or your local plumbing authority for more information.

## **⚠ DANGER**

This water heater's water temperature is set to 120°F (49°C) at the factory for your safety and comfort. Increasing the temperature increases the risk of accidental scalding. Water temperatures at or above 125°F (52°C) can cause instant scalding, severe burns, or death. Before you decide to change the temperature setting, read the following table carefully.

Temperature	Time to Produce Serious Burn
120°F (49°C)	More than 5 minutes
125°F (52°C)	1.5 to 2 minutes
130°F (54°C)	Approx. 30 seconds
135°F (57°C)	Approx. 10 seconds
140°F (60°C)	Less than 5 seconds
145°F (62°C)	Less than 3 seconds
150°F (65°C)	Approx. 1.5 seconds
154°F (68°C)	Approx. 1 second

- Regardless of the water heater's set temperature, higher temperatures may occur in certain circumstances:
  - In some cases, repeated small draws of water can cause the hot and cold water in the tank to "stack" in layers. If this happens, the water temperature can be as much as 30°F (15°C) hotter than the set temperature. This temperature variation is the result of your usage pattern and is not a malfunction.
  - Water temperature will be hotter if someone adjusted the thermostat(s) to a higher setting. Problems with the thermostat(s), or other malfunctions may result in higher than expected water temperatures.
  - If the water heater is in a hot environment, the water in the tank can become as hot as the surrounding air, regardless of the set temperature.
  - If the water supplied to the water heater is pre-heated, the temperature in the tank may be higher than the water heater's set temperature. Connecting an additional heat source, such as a solar water heating system, to the water heater inlet is not recommended, as it may reduce efficiency or cause malfunctions.
- According to the national standard American Society of Sanitary Engineering (ASSE 1070) and most local plumbing codes, the water heater's thermostat should not be used as the sole means to regulate water temperature to avoid scalds.

## **WARNING**

To prevent death, serious injury, or property damage:

- **Do not use or store flammable products, such as gasoline, solvents, or adhesives in the same room or area as the water heater.**

Keep all flammable products far away from the water heater and store them in approved containers. Keep the containers closed tightly and out of the reach of children and pets.

- Ensure the junction box cover and the heating element access door covers are in place. These covers keep debris from entering and potentially being ignited, and help keep any internal fires from spreading.

- **Prevent the water heater from getting wet.**

If the wiring, thermostat, or surrounding insulation becomes exposed to water, immediately turn off the water heater and have it inspected by a qualified professional. Water exposure can cause serious damage, and if the water heater is submerged in water due to flooding, or if the thermostat has been submerged, the entire unit must be replaced. Regularly inspect your water heater to ensure it remains dry, and take immediate action if it comes into contact with water.

- **High temperatures and pressures in the water heater may lead to an explosion.**

Ensure the included temperature and pressure (T&P) relief valve, which meets ANSI Z21.22 standards, is properly maintained and not blocked, capped, or plugged, as it discharges hot water to prevent such risks.

## **CAUTION**

- **The water heater is heavy.** Always lift the unit with assistance. Be careful not to drop the water heater while lifting or handling it to avoid bodily injury or damage to the unit.



- California law requires that all new and replacement water heaters and all existing residential water heaters be braced, anchored, or strapped to prevent falling or horizontal displacement due to earthquakes. At a minimum, all water heaters must be protected in accordance with the California Plumbing Code, or Section 17958.5, as amended by the city, county, or city and county. The California General Guidelines, entitled "Guidelines for Seismically-Reinforced Residential Water Heaters," are available through relevant government resources for homeowners and installers to ensure compliance with these safety standards.

California law requires the following Prop 65 warning to be provided:

## **WARNING**

Cancer and Reproductive Harm -  
[www.P65Warnings.ca.gov](http://www.P65Warnings.ca.gov)

## 2. About the Water Heater

### 2.1 Included Items

When you open the box, you will find the following items with the water heater. Check the box for each of the following items before installing the water heater.

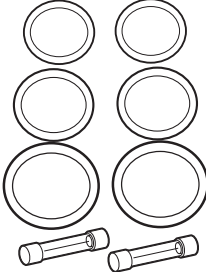
	
Installation Manual, User's Information Manual	Emergency Part Kit

**Note** To locate the emergency part kit on the water heater, refer to "6.10 Installing Emergency Part Kit for Repairs" on page 70.

### 2.2 Accessories

The following optional accessories are available for the water heater.

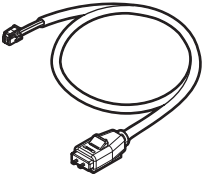
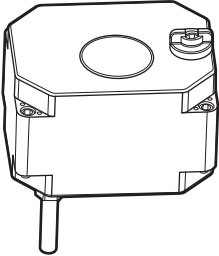
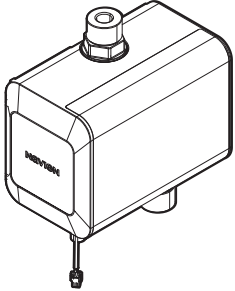
		
Navien Leak Detection System	Shut-off Valve	Navien Recirculation Pump

## 2.3 Specifications

The following table lists the specifications for the water heater. Additional specifications about water, electric, and air supplies appear in the Installation section.

Items	Model Series	NWP500-50	NWP500-65	NWP500-80			
	Model No.	NWP500S050AUMB	NWP500S065AUMB	NWP500S080AUMB			
<b>Capacity &amp; Efficiency</b>							
Nominal Capacity (gallons)		50	65	80			
Rated Storage Volume (gallons)		45.2	63.2	76.1			
UEF (Uniform Energy Factor)		3.85	4.03	4.05			
First Hour Rating (gallons)		65	80	85			
<b>Product General Data</b>							
Installation Location		Indoor					
Water Pressure		15–150 psi					
Connections Size	Cold Water Inlet	¾ in. NPT					
	Hot Water Outlet						
	Drain						
	T&P Relief Valve						
	Condensate Drain				¾" NPT Plastic connection		
	Heating Element				1" NPSM (Thread per Inch 11 ½)		
Materials	Casing	Cold Rolled Carbon Steel					
	Storage Tank	Stainless Steel					
	Condenser	Aluminum Coil					
Air In/Out Size	Air Intake	Ø8"					
	Air Exhaust	Ø8"					
Safety Devices		Condensate Level Sensor, ECO (Energy Cut Off), Temperature & Pressure (TP) Relief Valve.					
Dimensions		Ø21.7" × 63" (Ø 552 mm × 1,600 mm)	Ø25" × 63" (Ø 636 mm × 1,600 mm)	Ø25" × 71.6" (Ø 636 mm × 1,819 mm)			
Shipping Weight (lbs)		229	265	282			
<b>Electrical Data</b>							
Power Supply		208-240 V AC, 60 Hz, 1 Phase					
MCA		208 V (25.9A) / 240 V (28.8A)					
CKT BKR Amps		30A					
Wire Size		Up to 10 AWG (Suitable for 167°F (75°C))					
<b>Component Data</b>							
Compressor [LRA]		11.6A					
Fan Motor [FLA]		0.22A					
208 V	Compressor [RLA]		2.0A				
	Heating Element	Upper	3,755W				
		Lower	3,755W				
240 V	Compressor [RLA]		1.75A				
	Heating Element	Upper	5,000W				
		Lower	5,000W				
Max. Pressure	Discharge		2.654 MPa / 385 PSIG				
	Suction		1.724 MPa / 250 PSIG				
Refrigerant		R-134a					
Refrigerant Charge		28.2 Oz / 800 g					



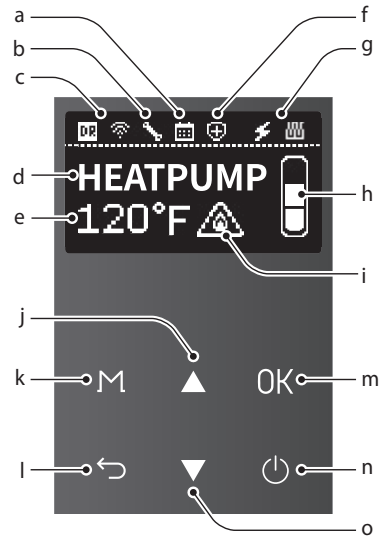

## 2.4 The Front Panel

The front panel allows you to adjust the water temperature and view the operating status or error codes. Remove the protective sheet from the front panel before using it.



**a**  **Schedule**  
Displays the schedule settings.

**b**  **Error status**  
Displays error status.

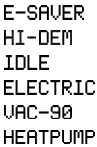

**c**  **Demand Response / Wi-Fi**  
Displays the when the DR module and Wi-Fi is connected



**d**  **Operation Mode**  
Displays the current operation mode.



**e**  **Set Hot Water Temperature**  
Displays the set hot water temperature.

**Anti-Legionella function**  
Displays when anti-legionella function is in progress. This icon appears even if the unit is currently in recirculation mode.

**f**  **Recirculation status**  
Displays the current recirculation mode.

-  Always On
-  Weekly
-  HotButton

g		<b>Heating Element status</b>	<ul style="list-style-type: none"> <li>•  Displays when the electric heater is operating.</li> <li>•  Displays when the heat pump is operating.</li> <li>•  Displays when the heat pump's operation stops.</li> </ul>	h		<b>Hot water charge rate</b> Displays the current hot water charge rate.
---	--	-------------------------------	--	---	--	---

i		<b>Scald warning / Freeze Protection</b>	<ul style="list-style-type: none"> <li>•  Displays a warning to alert you to the danger of scalding from hot water temperatures.</li> <li>•  Displays when the freeze protection function is operating.</li> </ul>	j		<b>Up button</b> Increases the temperature setting, parameter or moves down.
---	--	--	--	---	--	---

k		<b>Menu button</b> Change the operation mode and access to the menu screen.	l		<b>Back button</b> Access to the previous screen.
---	--	--	---	--	--

m		<b>OK button</b> Access to the selected item.	n		<b>Power button</b> Turns the water heater on or off.
---	--	--	---	--	--

o		<b>Down button</b> Decreases the temperature setting, parameter or moves down.
---	--	---

## 2.5 Components

The following diagram shows the key components of the water heater. Component assembly diagrams and particular parts lists are included in the Appendixes.

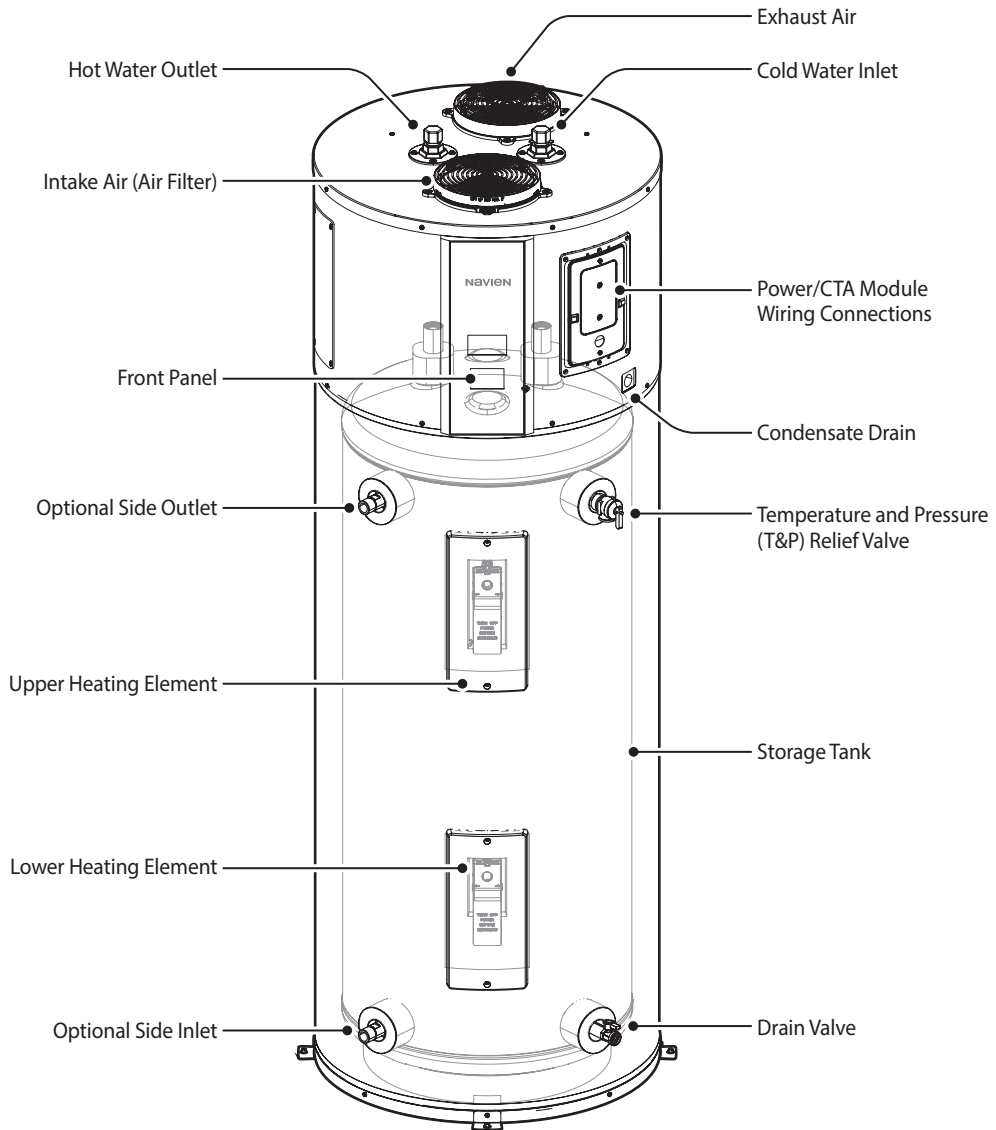

## 2.6 Dimensions

The following diagrams show the dimensions of the water heater and the table lists the supply connections.

### NWP500-50

	Description	Diameter
A	Intake / Exhaust	Ø8" (Ø203 mm)
B	Cold water inlet	NPT ¾"
C	Hot water outlet	
D	Temperature and pressure (T&P) relief valve	
E	Hot water outlet	
F	Drain valve	
G	Cold water inlet	

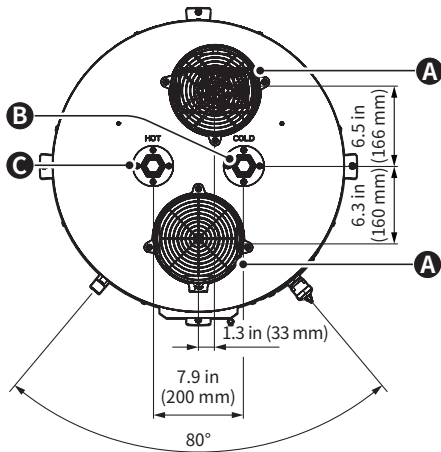

[Top View]

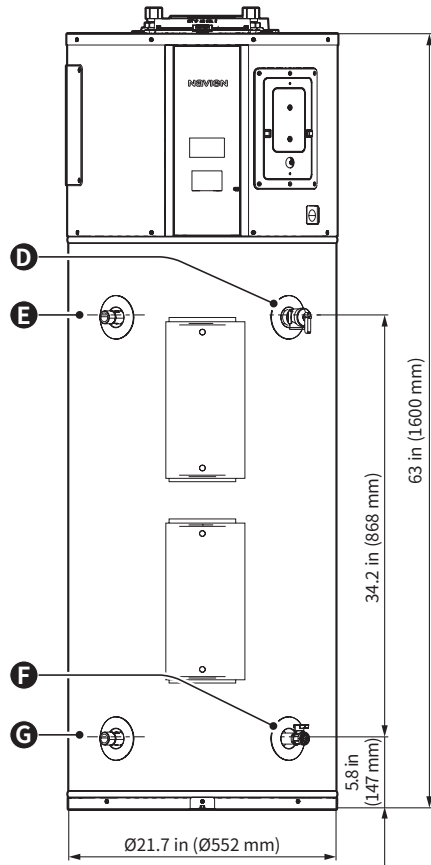

[Front View]

## NWP500-65

	Description	Diameter
A	Intake / Exhaust	Ø8" (Ø203 mm)
B	Cold water inlet	NPT ¾"
C	Hot water outlet	
D	Temperature and pressure (T&P) relief valve	
E	Hot water outlet	
F	Drain valve	
G	Cold water inlet	

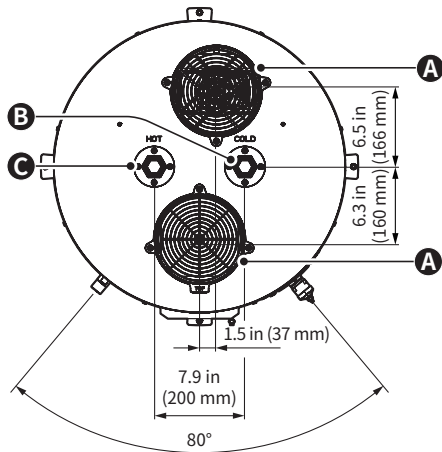

**[Top View]**

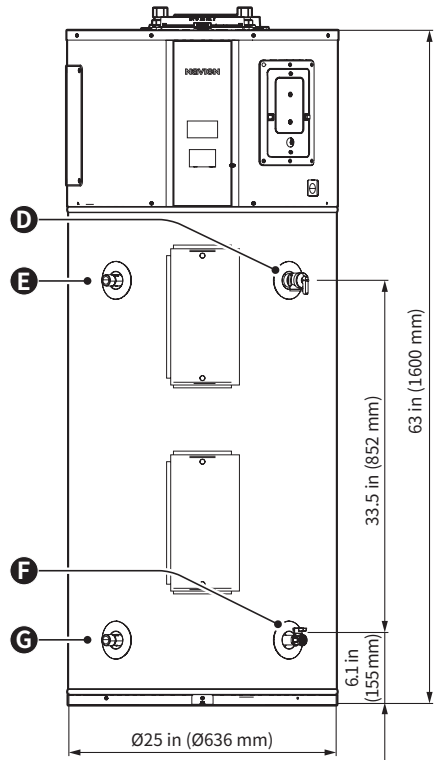

**[Front View]**

## NWP500-80

	Description	Diameter
A	Intake / Exhaust	Ø8" (Ø203 mm)
B	Cold water inlet	NPT ¾"
C	Hot water outlet	
D	Temperature and pressure (T&P) relief valve	
E	Hot water outlet	
F	Drain valve	
G	Cold water inlet	

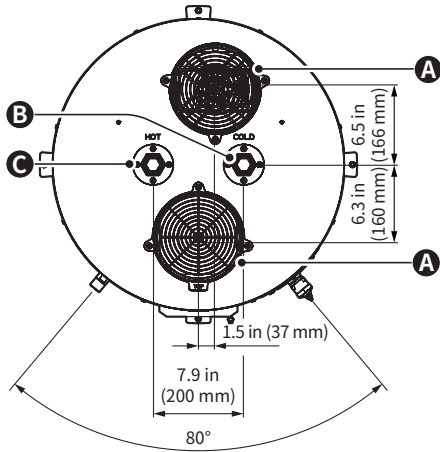

[Top View]

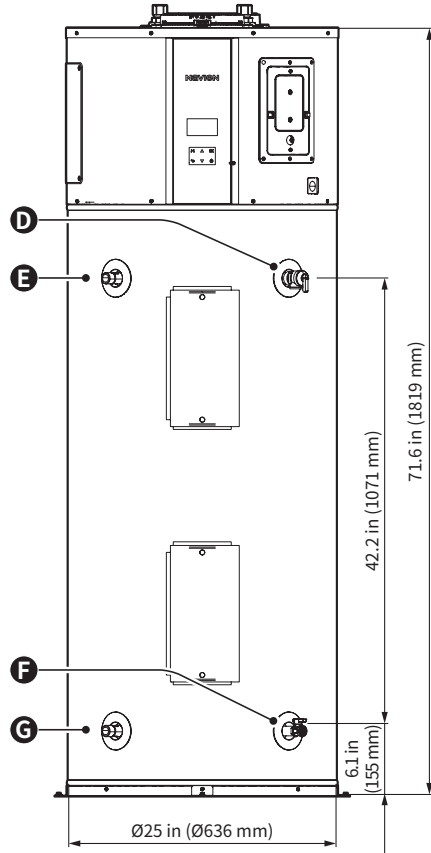

[Front View]

## 2.7 Rating Plate

The Navien NWP500 electric heat pump water heater comes pre-configured from the factory to operate on 208V/240V 60Hz power. Before beginning the installation, check the rating plate on the side of the unit to confirm that the electrical supply and water pressure at the installation site are compatible with the water heater.

### **⚠ WARNING**

To prevent death, serious injury, or property damage:

**Before starting installation**, check the rating plate to ensure that the electrical supply specifications available at the installation location match the water heater. Do not install the water heater if it does not match the contents of this rating plate. Using an incorrect type of electrical power supply may cause the water heater to operate abnormally or malfunction.

The electrical supply must be connected by a licensed professional electrician. Grounding must be connected during electrical construction. Use wires with a gauge of AWG10 or higher and suitable for 167°F (75°C). Install a power breaker with a capacity greater than that specified on the rating plate.

**Navien Inc. is not responsible for property damage, fatal injuries, and death caused by improper installation.**

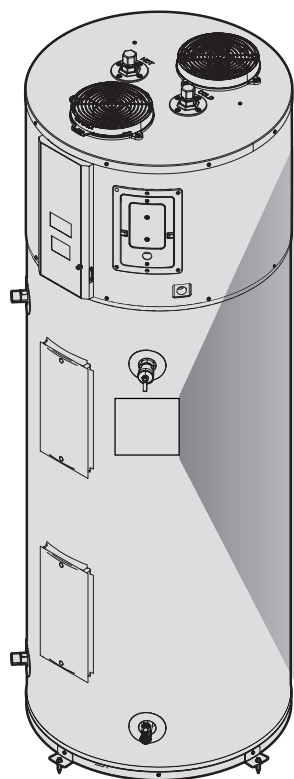

## NAVIENTM

Heat Pump Water Heater  
Chauffe-eau à thermopompe  
Indoor installation (Installation à l'intérieur)

Navien, Inc. / 20 Goodyear, Irvine, CA 92618 / Tel: 1-800-519-8794

Model No. *Numéro de modèle	NWP500S050AUMB		
Nominal Volume *Volume nominal	50 Gal		
Rated Storage Volume * Volume de stockage	45.2 Gal		
Max. Working Pressure *Pression de service max.	150 PSI (1,034 kPa)		
Volts	208 / 240	Hertz	60
		Phase	1
Compressor (LRA) *Compresseur (LRA)	11.6 A		
Fan Motor (FLA) *Moteur du ventilateur (FLA)	0.22 A / $\frac{1}{50}$ HP		
Min Supply Circuit Ampacity	28.8A		
*Courant admissible min. du circuit d'alimentation			
Max. Fuse or Circuit BRK Size,	30A		
*Capacité max. du fusible ou du disjoncteur			
Max. Pressure(Ref. Circuit Discharge) Pression max.(refoulement du circuit réf.)	385 psig / 2654 kPa		
Max. Pressure(Ref. Circuit Suction) Pression max.(aspiration du circuit réf.)	250 psig / 1724 kPa		
Refrigerant *Réfrigérant	R-134a		
Refrigerant Factory Charge *Charge de réfrigérant à l'usine	28.2 Oz / 800 g		
Temperature&Pressure (TP) Relief Valve Capacity	150 PSI, 210°F,		
*Capacité de la soupape de détente de température et de pression (TP)	ANSI Z21.22		

Volts AC *Volts AC	Compressor *Compresseur (RLA)	Upper Elements *Éléments supérieure	Lower Elements *Éléments inférieurs
240 V	1.75 A	5.0 kW	5.0 kW
208 V	2.0 A	3.8 kW	3.8 kW

\* FOR INSTALLED RATING SEE ELEMENT MARKING

\* MAXIMUM ALLOWABLE RATINGS (240 V): 5.0 kW for Upper / Lower Element, 6.9 kW for the product



- Conforms to UL STD 60335-1,  
60335-2-40 and 174  
- Certified to CSA STD C22.2 # 60335-1,  
60335-2-40 and 110



FC Contains:  
FCC ID : P53-EMC3290  
IC ID : 23507-EMC3290



### 3. Installing the Water Heater

#### 3.1 Installation Diagram

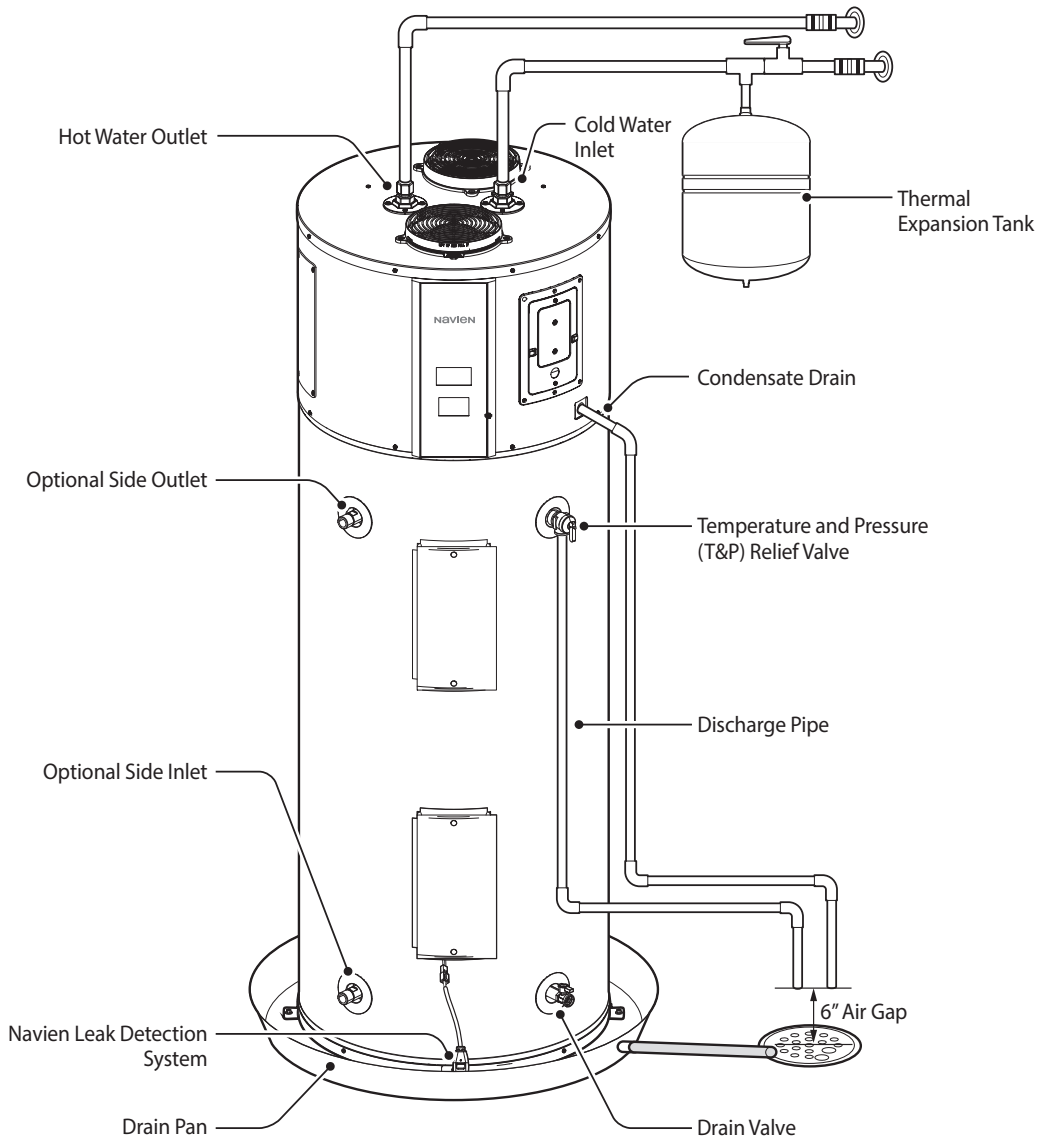

#### **NOTICE**

- If copper piping is used for the water lines, dielectric unions (field-supplied) must be installed at the water connections to prevent galvanic corrosion.
- Install the cold and hot water lines to the desired inlet and outlet, either top or side (not both), and cap any unused inlets or outlets to prevent water leaks.



## 3.2 Considerations for Proper Installation

### Plumbing Code

Ensure that your system meets current plumbing code standards, as there may have been updates since the installation of your old water heater. Installing the approved accessories and making any necessary changes to bring your home up to date with the latest code requirements is recommended.

#### **CAUTION**

Condensate drain installation must comply with all applicable local plumbing codes, including requirements for indirect connection, air gap, and backflow prevention.

### Water Pressure

Most plumbing codes permit a maximum incoming water pressure of 80 psi; however, maintaining a working pressure of 50–60 psi is recommended.

- To measure the maximum water pressure in your home, connect a water pressure gauge to the cold water line and monitor it throughout the day.

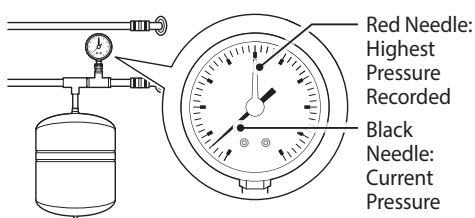

- To limit your home's water pressure, install the pressure reducing valve (PRV) on the main incoming cold water line and adjust it to a setting between 50 and 60 psi. Note that some homes may experience pressures exceeding 100 psi.

#### **WARNING**

Excessive water pressure may damage water heaters, leading to premature leaks and potential property damage.

**Note** When purchasing a PRV, ensure it includes a built-in bypass feature.

### Water Pressure Increase Caused by Thermal Expansion

Current plumbing codes require a correctly pressurized and sized thermal expansion tank in all homes equipped with backflow preventers, check valves, or pressure reducing valves.

Ensure that you have a properly sized thermal expansion tank installed. Install the thermal expansion tank on the cold water supply line near the water heater. For specific installation details, refer to the instructions provided with the thermal expansion tank.

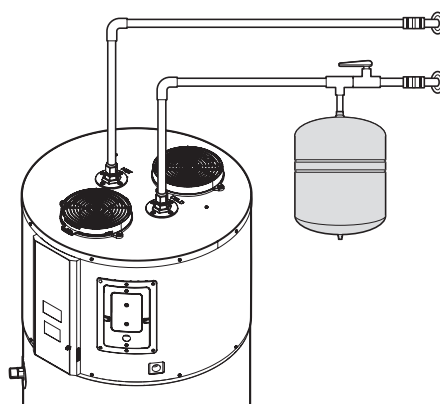

### Water Pipe and Tank Leaks

Leaks from plumbing pipes or the water heater itself may cause property damage and pose fire risk. To prevent this:

- Install a leak detector system with an automatic shutoff valve. These systems can detect water leaks and shut off the water supply to the water heater.
- Navien recommends installing a drain pan beneath the water heater. Check local code requirements in placing the water heater in a drain pan connected to an adequate drain. Refer to "3.4.4 Installing the Drain Pan" on page 25 for more information.
- Install the Navien leak detection system (optional) facing the drain pan. Refer to "3.12 Installing the Navien Leak Detection System (Optional Accessory)" on page 32 for more details.

## Mixing Valve Installation

- Install thermostatic mixing valves (field supplied) to control the water temperature supplied to each point-of-use in accordance with local code.

### **WARNING**

Hot water can cause scalding, even if the water heater thermostat is set to a relatively low temperature. Installing thermostatic mixing valves at each point-of-use can reduce this risk.

- If you are unsure whether your plumbing system has properly installed and adjusted thermostatic mixing valves, consult a qualified professional.

## 3.3 Choosing an Installation Location

### Installation and Environmental Requirements

Before installing the water heater, ensure that it is:

- Installed indoors, close to where the domestic water supply enters the building.
- Installed in a location where the air filter and condensate drain are easily accessible for maintenance and service.
- If the local code requires, placed in a suitable drain pan that is piped to an adequate floor drain or directed outside the building.
- Located in an area that will not be exposed to freezing temperatures.

#### **Note**

- If installed in an area where temperatures may drop below 32°F (0°C), you should insulate each pipe to prevent freezing.
- The heat pump operates efficiently within an air temperature range of 41°F to 113°F (5°C to 45°C). Outside this range, the heat pump will cease operation and the heating elements will only be used to produce hot water.

- Positioned in a location suitable for vertical installation on a level surface.

### **CAUTION**

Ensure the water heater is installed level, with no more than a 5-degree tilt, to maintain proper operation, prevent internal damage, and ensure safety. Tilting beyond this limit may hinder drainage and cause damage.

- Installed in an area where noise will not be a concern.
- Not intended for use as a space heating source.
- Placed in an environment free from corrosive heating elements, excessive dust, or lint, as these can impact water heater's performance.

### Ensuring Adequate Space (Clearances)

Ensure that the installation location provides adequate space (clearances) for regular maintenance and servicing. For optimal efficiency in unvented applications, the water heater must have unrestricted airflow and a minimum installation space of 640 ft<sup>3</sup> (18.1 m<sup>3</sup>).

When installing the water heater:

- Maintain a minimum clearance of 6 inches (152 mm) from the front and 12 inches (305 mm) from the top of the unit. For easier future servicing, a clearance of at least 3 feet (0.9 m) from any obstruction on the front side is recommended.

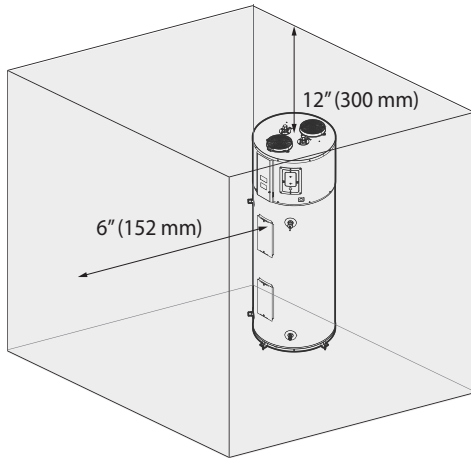

Clearance from:	Indoor Installation
Front	6" (152 mm)
Top	12" (305 mm)
Sides & Rear	Zero Clearance

- Verify that the floor can support the weight of the water heater when fully filled.

Nominal Volume	Filled Weight	
50 Gallon	Total	558 lbs (253 kg)
	Water	377 lbs (171 kg)
	Product (Dry)	181 lbs (82 kg)
65 Gallon	Total	731 lbs (332 kg)
	Water	527 lbs (239 kg)
	Product (Dry)	204 lbs (93 kg)
80 Gallon	Total	855 lbs (388 kg)
	Water	635 lbs (288 kg)
	Product (Dry)	220 lbs (100 kg)

## **⚠ DANGER**

If the floor is not solid, the added weight could cause it to buckle or break, potentially resulting in property damage, serious injury, or death.

### **Location Considerations to Prevent Water Damage**

Avoid installing the water heater in locations such as attics, upper floors, or any areas where a leak could damage the structure or furnishings.

Due to the natural corrosive action of water, the tank will eventually leak. To minimize potential property damage, regularly inspect and maintain your water heater. Leaks often occur in the plumbing system itself, rather than in the water heater.

### **Air Circulation Requirements for Installation**

This water heater should not be installed in areas without proper air circulation from the outside.

If installed in an enclosed space, the heat pump system may cause the temperature within that space to drop, potentially reaching a point where the heat pump cannot operate efficiently, resulting in reduced performance of the water heater.

The unit must not be placed in a closet or small enclosure (less than 640 ft<sup>3</sup> [18.1 m<sup>3</sup>]) unless adequate air exchange provisions are made, such as vented or louvered doors, wall grilles, or ducting.

- Wall grilles must have a minimum size of 22 inches by 6 inches or provide an equivalent net free airflow area of at least 130 in<sup>2</sup>.
- For small enclosures with an installation space of 84 ft<sup>3</sup> to 639 ft<sup>3</sup> (2.3 m<sup>3</sup> to 18.1 m<sup>3</sup>), acceptable ventilation methods include:
  - A fully louvered door.
  - One wall grille located at least 12 inches from the ceiling and a second grille positioned at least 12 inches from the floor.

## Minimum Space Volume for Optimal Efficiency

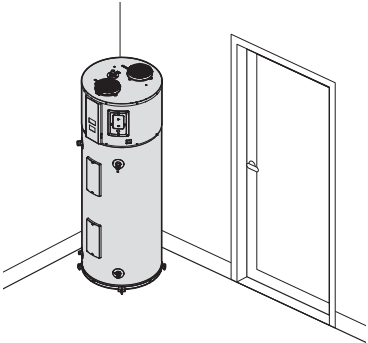
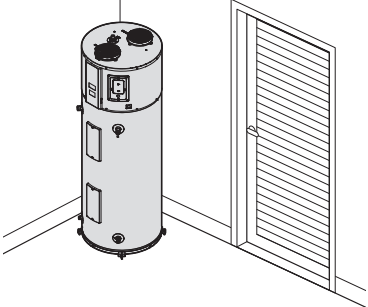
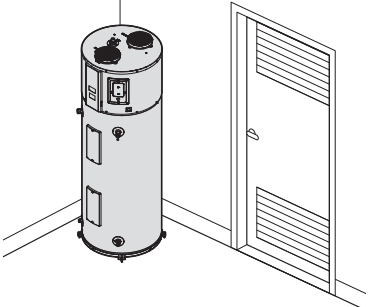
Configuration Type	Ducting Type	Min. Space (ft <sup>3</sup> )	Example Dimensions (L×W×H) [ft]	Ventilation Required
<p><b>Enclosed Room</b></p> 	N/A	> 640	8 × 8 × 10	N/A
<p><b>Fully Louvered Door</b></p> 	N/A	> 84	3 × 2.8 × 10	○
<p><b>Upper &amp; Lower Louvers in Door</b></p> 	N/A	> 84	3 × 2.8 × 10	○

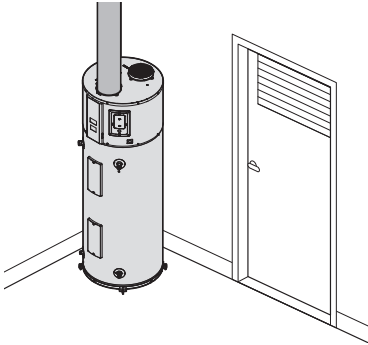
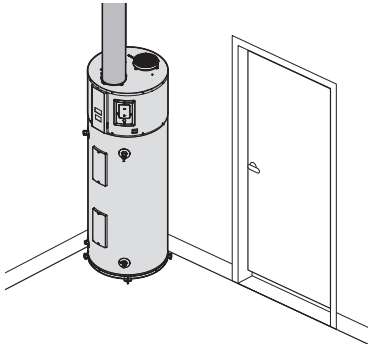
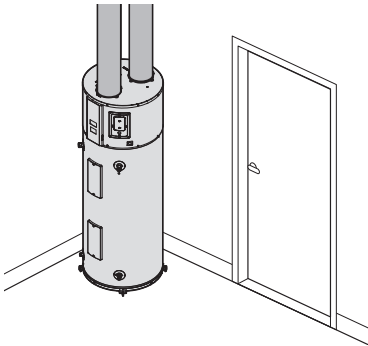
Configuration Type	Ducting Type	Min. Space (ft <sup>3</sup> )	Example Dimensions (L×W×H) [ft]	Ventilation Required
<b>Inlet or Outlet Ducting and Single Louver</b> 	Inlet or Outlet	N/A	N/A	○
<b>Inlet or Outlet Ducting and Undercut Door</b> 	Inlet or Outlet	N/A	N/A	○
<b>Inlet &amp; Outlet Ducting</b> 	Inlet and Outlet	N/A	N/A	N/A

**Note**

- The minimum louver size must provide a free area of at least 130 in<sup>2</sup>.
- The undercut door must have a minimum gap of 0.75 inches, allowing an air passage area of at least 18 in<sup>2</sup>.
- If a louver is installed, it should be positioned near the top of the water heater.
- This water heater supports various duct diameters, including both rigid and flexible ducts. Refer to “3.5 Ducting Requirements” on page 26 for maximum allowable duct lengths based on the installed diameter.
- Ensure that the minimum space requirements are strictly followed. Failure to do so may lead to reduced system efficiency.
- When installed in an enclosed room with only the minimum space, the ambient room temperature may drop, potentially increasing the water heater’s recovery time.

## Earthquake Safety Requirements

Ensure that your area is not prone to earthquakes. If it is, install special straps as required by local building codes to secure the water heater.

### DANGER

Failure to properly secure the water heater could result in property damage, serious injury, or death if it falls over during an earthquake.

**Note** The state of California requires that all water heaters be braced, anchored, or strapped to prevent movement during an earthquake.

Ensure the water heater is installed in a location that is not prone to physical damage from vehicles, flooding, or other risks.

The installation must comply with safety regulations outlined in the California Plumbing Code or Section 17958.5.

For specific guidelines on earthquake bracing for residential water heaters in California, refer to the “Guidelines for Earthquake Bracing Residential Water Heater.” These instructions can be obtained by:

- Writing to the California Department of General Services, Division of the State Architect, 1102 Q Street, Suite 510, Sacramento, CA 95814.
- Visiting the following website: California Department of General Services

## 3.4 Connecting Water Pipes

- Note**
- Review all instructions thoroughly before connecting the water pipes to the water heater. If you require assistance, contact a licensed professional or Navien Technical Support at 1-800-519-8794.
  - Most codes require that the water heater be placed in a drain pan piped to an adequate drain. The drain pan helps prevent property damage from condensation or leaks in the piping connections or tank.
  - This appliance must be permanently connected to the water mains. Hose-sets must not be used as water supply connections.

Connect the cold water supply line to the water heater's cold inlet and the hot water outlet line to the hot outlet, ensuring all fittings are secure and leak-free. Also, install the temperature and pressure (T&P) relief valve with a properly sized discharge pipe directed to an appropriate drain, and ensure the condensate drain line is correctly installed and unobstructed.

Before connecting water pipes to the water heater, ensure the water heater is correctly set in place and check the following:

- The T&P relief valve is not in contact with any electrical parts.
- There is sufficient space to install the T&P relief valve discharge pipe.
- There is adequate space to install proper condensate drain tubing.
- There is enough access and clearance around the water heater for future maintenance. Maintain a minimum clearance of 6 inches (152 mm) from the front side of the water heater.

**Note**

The water quality must comply with the specifications listed in the following table.

Contaminant	Maximum Allowable Level
Total Hardness	Up to 200 mg/l (12 grains/gallon)
Aluminum	0.05 to 0.2 mg/l
Chloride	Up to 250 mg/l
Copper	Up to 1.0 mg/l
Iron	Up to 0.3 mg/l
Manganese	Up to 0.05 mg/l
pH	6.5 to 8.5
Sulfate	Up to 250 mg/l
Total Dissolved Solids (TDS)	Up to 500 mg/l
Zinc	Up to 5 mg/l
Chlorine	Up to 4 mg/l

- If required, install approved insulation on the condensate drain to prevent external condensation.
- Provide sufficient length on the condensate drain pipe or tubing to reach an adequate drain.
- Ensure that the condensate drain outlet is not submerged in the discharge area.
- Ensure the condensate line is plumbed to allow water to flow freely. Use of excessive run or bends will cause restrictions in the condensate drain.
- If a nearby drain is unavailable, then a condensate pump with a capacity no less than 2 GPD must be installed and routed to an alternative drain. Follow condensate pump manufacturer's instructions for installation.

### **! CAUTION**

- Condensate drain installation must comply with all applicable local plumbing codes, including requirements for indirect connection, air gap, and backflow prevention.
- Do not connect condensate drain line with other drain or discharge lines into a single pipe or line. Combining the condensate drain line with other drains or discharge lines can lead to potential issues such as blockages, improper drainage, and cross-contamination. Each line should be run separately to ensure proper drainage and system functionality.

### 3.4.1 Connecting Condensate Drain Lines

The female thread size of the condensate drain is NPT 3/4" and ensure that the condensate line is pitched downward at least 1/4" per 1 foot of line for proper drainage.

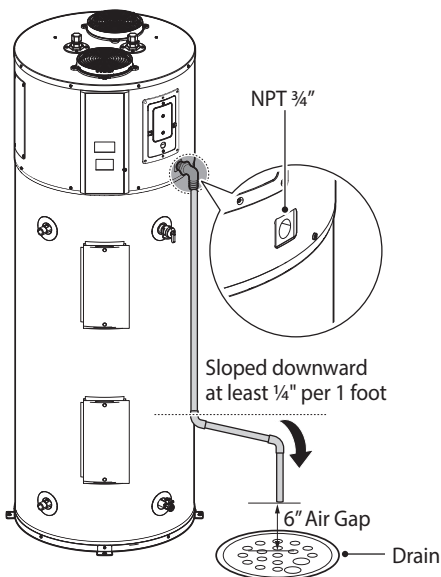

### 3.4.2 Connecting the Water Supply Lines

When connecting the water supply, follow these guidelines:

#### Note

- For easier removal of the water heater for service or replacement, connect the water pipes with unions. Dielectric unions can help prevent corrosion caused by small electric currents common in copper water pipes.
- Ensure the thermocline tube inside the water supply and hot water outlet pipes is not damaged, as this could affect water temperature.
- Install insulation or heat tape on the water pipes, especially if the indoor area is prone to freezing temperatures. Insulating hot water pipes can improve energy efficiency.
- Top inlet and outlet connections have built-in heat traps, while the side connections do not. Check local code if a heat trap is required. If required, install a heat trap nipple, insert, or piping in accordance with local code.

1. Determine the type of water pipes in your home.

#### Note

Use pipe materials and sealants that are approved for use with potable water.

2. Select the plumbing connections. The water heater can be connected to either the top or side connections, but not both.
3. Connect the cold water supply line using  $\frac{3}{4}$ " National Pipe Thread (NPT) to the cold water connection on either the top or side of the water heater.

#### CAUTION

Do not overtighten to avoid damaging the gaskets.

4. Connect the hot water supply using  $\frac{3}{4}$  inch NPT to the corresponding hot water connection.
5. Double-check that the hot and cold water pipes are connected to the correct fittings on the water heater. Ensure that all unused hot and cold connections are plugged and capped.
6. If necessary, install the home's pressure reducing valve to 50-60 psi and a thermal expansion tank.
7. Fill the water heater, open each hot water faucet slowly to allow air to vent from the water heater and piping.

#### CAUTION

- Consult with local plumbing officials to confirm the suitable pipe materials for your area.
- Do not solder pipes while they are attached to the water heater, as the inlet and outlet connections have non-metallic parts that could be damaged. Instead, solder a short length of pipe to a threaded adapter using 95/5 tin-antimony solder or an equivalent. When connecting the home's water pipes, use wet rags to keep the connections at the water heater cool while soldering.



### 3.4.3 Connecting the Temperature and Pressure (T&P) Relief Valve Discharge Pipe

#### **⚠ WARNING**

- To prevent serious injury or death from explosion, do not reuse an old T&P relief valve.
- The pressure rating of the T&P relief valve must not exceed 150 psi to prevent excessive pressure buildup. Exceeding this limit may lead to dangerous situations, including tank ruptures or explosions, as well as damage to plumbing systems.
- Do not connect any valve or other restriction to the T&P relief valve. If a valve or restriction is installed, it could block or limit the relief valve's function, preventing it from releasing pressure when needed. This could cause dangerous pressure buildup, potentially leading to an explosion or severe damage to the water heater and surrounding property.

The temperature and pressure (T&P) relief valve is pre-installed at the factory. Connect the discharge pipe to the T&P relief valve's outlet in accordance with local codes.

- Install a discharge pipe with a minimum diameter of  $\frac{3}{4}$ " and ensure it is properly sloped for drainage.
- The discharge pipe must be able to withstand temperatures of up to 250°F (121°C) without kinking.
- The discharge pipe should end within 6" (15 cm) of the floor and all piping must be kept free from freezing.
- Ensure there are no blockages between the water heater and T&P relief valve.

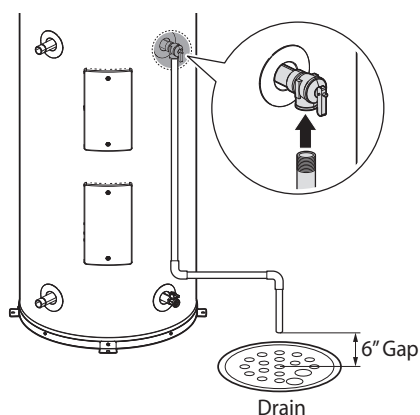

### 3.4.4 Installing the Drain Pan

#### **⚠ CAUTION**

- Without a drain pan, any leaks from the water heater may cause serious damage to nearby walls, floors, and subfloors.
- If the water heater is on an upper level, leaks could also damage the ceilings and walls below.

A drain pan must be installed underneath a water heater to catch any leaks that may occur as per local code, if they exist. The drain pan is equipped with a fitting on its side, which connects to a pipe leading to a drain. If water leaks into the drain pan, it will flow through the pipe and safely into the drain.

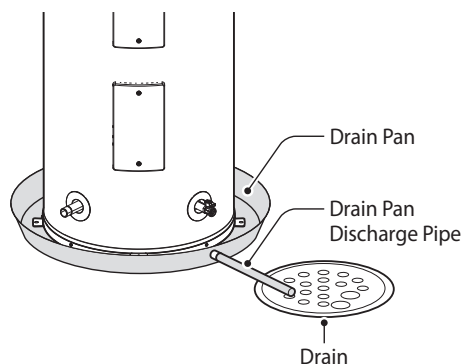

#### **Note**

- The drain pan must be at least 2" (50 mm) wider than the diameter of the water heater and must not exceed a depth of 1- $\frac{3}{4}$ ".
- Ensure the drain pan is placed on a level surface.
- The drain pan must be capable of supporting the full weight of the water heater when filled with water.
- Connect the outlet on the side of the drain pan to a drainage system to allow for proper water discharge.

### 3.4.5 Installing the Thermal Expansion Tank

As water temperature increases, its volume may expand, leading to a significant rise in pressure within the piping. To prevent this, an expansion tank must be installed on the water supply line.

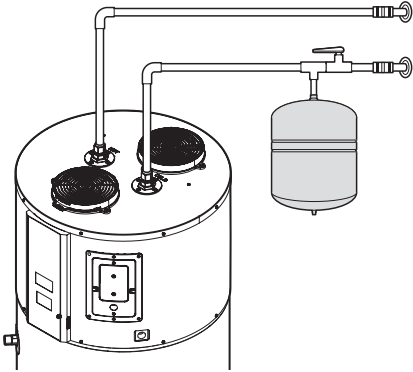

**Note** There may be a check valve, pressure-reducing valve, water meter, or water softener in the cold water supply line, which can create a closed-loop system. Check if a check valve is installed in the cold water supply line of the water heater. If so, install an expansion tank between the check valve and the water heater.

## 3.5 Ducting Requirements

The heat pump unit on top of the water heater absorbs heat from air entering through the intake, transferring this heat to the water inside the storage tank.

When set to Heat Pump, Energy Saver, or High Demand mode, the unit draws indoor or outdoor air through the upper air inlet, then releases cooled, dehumidified air through the outlet, and discharges condensate through the drain connections. The cold, dry air and condensate are normal byproducts of its operation. Use only insulated ducting to prevent condensation forming on the ducting.

For unvented installations, a minimum space of 640 ft<sup>3</sup> (18.1 m<sup>3</sup>) is required. However, if provisions for air exchange are made, the water heater can be installed in smaller enclosures with a minimum space of 84 ft<sup>3</sup> (2.3 m<sup>3</sup>).

Duct elbows or flexible ducts can be connected to the duct adapters on top of the unit to redirect intake and exhaust air, which:

- Allows installation in limited spaces.
- Improves water heater performance.
- Maintains the comfort of your living space.

**Note** If the installation space is small and poorly ventilated:

- The space temperature may drop, preventing the heat pump unit from operating.
- Lower air temperatures can reduce the unit's performance and efficiency, affecting the water heater's overall efficiency.
- The reduced air temperature may cause condensation on walls, potentially leading to property damage.

## Duct Installation Guidelines

Follow these guidelines to ensure safe, efficient, and code-compliant duct installation. They cover proper routing, sizing, support, termination placement, and airflow considerations. Use approved materials, prevent air recirculation and condensation, and stay within the specified maximum duct length to maintain optimal performance.

- Always follow local building and HVAC codes.
- Connect ducts outdoors or to designated spaces per these guidelines—noncompliant systems are not supported.
- Do not connect the water heater to existing ductwork, as it may cause malfunction or failure.
- Use HVAC-approved and UL-approved ducts and terminations to ensure airflow and prevent water ingress.
- Support ducts to maintain horizontal or vertical alignment.
- Keep rigid ducts clear of floor joists to reduce noise and vibration. Use a short flexible duct between the water heater and rigid ducts for isolation.
- Each foot of flexible duct counts as three feet of rigid duct.
- Insulate ducts per HVAC code to prevent condensation. Exhaust must discharge far enough from the building to avoid surface condensation.
- This heater is designed for efficient airflow and maximum heating with warm, humid air.
- Route ducts as directly as possible.
- Minimize the use of elbows.
- Use ducts with the largest possible airflow area (e.g., diameter for round ducts).
- Use the largest possible terminations.
- The placement and direction of terminations should prevent discharged air from being recirculated. Recirculation of cold air through the intake can reduce the performance of the water heater due to lower air temperatures.
- The total duct length is the combined length of inlet and outlet ducts. Do not exceed the "maximum duct length" specified in the table—performance is not guaranteed beyond this limit.

## Duct Configuration

- Two duct adapters are available: one for the air intake and one for the exhaust, both accepting 8-inch diameter ducting with no additional adapters needed.
- Smaller duct diameters (7", 6", and 5") are supported. Refer to the provided table for allowable duct lengths, accounting for reducers and up to 10 feet of 8-inch rigid ducting (two elbows) before the reducers.
- Duct reducers must be installed within 10 feet (two elbows) of the unit or within 2 feet of the duct termination.
- A minimum of 12 inches of flexible ducting (8-inch diameter) must be installed between duct adapters and any rigid ducting.
- Air can be drawn from or expelled to the outdoors, attic spaces, or other indoor rooms.

### [Maximum Duct Length]

Duct Type	Diameter			
	8"	7"	6"	5"
Rigid	300'	155'	65'	17'
Flexible	100'	50'	24'	-

### [Equivalent feet for Duct Accessories]

Description	Diameter			
	8"	7"	6"	5"
Elbows/Flexible Bends (Each)	5'	5'	5'	5'
8 inch UL Certified Termination for ducting outside (Each)	5'	5'	5'	5'
Reduced diameter UL Certified Termination for ducting outside (Each)	N/A	10'	15'	20'
8 inch Register for ducting inside (Each)	5'	5'	5'	5'
Reduced diameter Register for ducting inside (Each)	N/A	10'	15'	20'
Rodent Screen (must be greater than 83% open area) (Each)	1'	1'	1'	1'

## **Air Intake Considerations**

- Outdoor air temperatures may often fall below 37°F (3°C) in many regions during fall and winter.
- Ducting outdoor air to the intake may increase the load on heating and cooling systems unless the exhaust air is also directed elsewhere.
- Drawing air from another indoor location may create negative pressure, pulling in outside air and potentially increasing the load on the heating and cooling systems. If ducting outdoor air to the intake, ensure that the intake is far away from other exhaust ducting from a different appliance such as a dryer.

## **3.6 Connecting the Power Supply**

### **WARNING**

#### **Electric Shock Hazard**

To prevent serious injury or death:

- Ensure that the proper switch is turned OFF at the breaker panel before connecting the power supply.
- Do NOT use the water heater if it is damaged. Contact a qualified technician or service agency before proceeding with the installation.
- ALWAYS follow all applicable electrical codes of the local authority having jurisdiction.
- In the absence of such requirements, follow the latest edition of the National Electrical Code (NFPA 70) in the USA or the latest edition of CSA C22.1 Canadian Electrical Code Part 1 in Canada.
- ONLY licensed professionals should connect the power supply.

When connecting the power supply, follow these guidelines:

- Do not connect the electric supply until all plumbing and electrical wiring is complete and the water heater has been filled with water.
- Connect the water heater to a 208 - 240 V AC power supply at 60 Hz, 30A. Do NOT connect the water heater to a 110 - 120 V AC power supply. Doing so will damage the water heater and void the warranty.
- Connect the water heater to a dedicated branch circuit with a maximum of 30 A rating electrical supply.
- The water heater must be electrically grounded before connecting to the power supply. Do not attach the ground wire to the water piping as plastic pipe or dielectric unions may prevent proper grounding.
- If there is a power failure in cold weather areas, the freeze protection system in the water heater will not operate and may result in freezing of the heat exchanger. In cold weather areas where power failures are common, you must completely drain the water heater to prevent damage if the power will be off for any extended period of time. A battery back-up or generator may be used to supply hot water during periods of power outages. Damage caused by freezing temperatures due to power loss is not covered under warranty.

If you are not using your water heater for a long period of time:

1. Completely drain the water out of the water heater.
2. Disconnect the power supply to the water heater. This prevents your water heater from freezing and being damaged.

### **WARNING**

#### **Electric Shock Hazard**

To prevent serious injury or death:

- ALWAYS label all wires before disconnecting them when you work on the controls.
- Wiring errors can cause improper and dangerous operation.
- ALWAYS verify proper operation after servicing.

### 3.6.1 Connecting the Power Supply Wires

#### **⚠ DANGER**

Do not work on an energized circuit. Doing so may cause severe injury or death due to electrical shock.

#### **NOTICE**

Do not turn on electrical power until the tank is completely filled with water and all air is purged. Although the water heater has "Dry-Fire" protection, ensure the tank is fully filled before making electrical connections.

1. Ensure the electrical power to the water heater is turned off at the circuit breaker panel (or by removing the circuit's fuses).
2. Use a non-contact circuit tester to confirm that the power is off and the circuit is not energized.
3. Check the rating plate on the side of the water heater and ensure that the home's voltage, wiring size, and circuit breaker rating and type match the water heater's requirements. The water heater requires a 208/240 VAC, single-phase, 30-amp power supply.

#### **Note**

- For more information on the rating plate, refer to "2.7 Rating Plate" on page 15.
- Follow all applicable local codes for wiring. In the absence of local codes, adhere to NFPA-70 and the latest edition of the National Electric Code (NEC).

4. Loosen the two screws to remove the junction box cover from the power/CTA module.

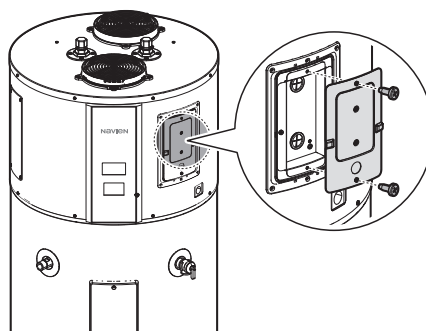

5. Connect the ground wire to the green ground screw, then connect the home's two power wires to the two wires of the water heater.

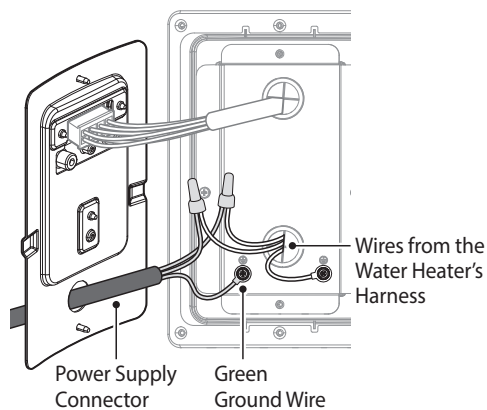

6. Install the junction box cover and secure it with the two screws.

#### **⚠ WARNING**

Make sure the junction box cover is securely in place to reduce the risk of fire and electric shock. If any parts are submerged in water, remove the product from service and contact qualified personnel to replace the water heater. Always disconnect all electrical connections, even when performing maintenance.

### 3.6.2 Ground Wiring

If a metal conduit is used as the grounding conductor:

- The grounding electrode conductor must be a 10-gauge solid copper wire, continuous and without splices or joints.
- Rigid metal conduit, intermediate metal conduit, or electrical metallic tubing may be used for grounding if they are terminated in fittings approved for grounding.
- Flexible metal conduit or flexible metallic tubing can be used for grounding if the following conditions are met:
  - The length of any ground return path does not exceed 6 feet (1.8 m).
  - The circuit conductors are protected by overcurrent devices rated at 30 amperes.
  - The conduit or tubing is terminated in fittings approved for grounding.

For complete grounding details and any allowable exceptions, refer to the current edition of the National Electric Code (NFPA-70).

### 3.7 Insulation Blanket

If local codes require an insulation blanket, follow the manufacturer's instructions included with the kit.

#### **⚠ CAUTION**

- This water heater does not require an insulation blanket, and the manufacturer's warranty does not cover damage or defects caused by the use of any energy-saving or unapproved devices.
- Do not cover or move the operating or warning labels on the water heater when applying insulation.
- Do not cover the air openings on the water heater.
- Do not cover the front panel, T&P valve, or drain valve.

### 3.8 Removing the Battery Protective Film

After completing the installation and before connecting the water heater to power, remove the battery protective film from the side of the front panel.

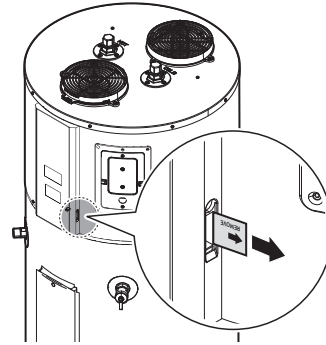

### 3.9 Demand Response (CTA-2045) Installations

A CTA2045-compliant module can be connected to the water heater's designated connection port. Follow the supplier's specific instructions for initial module startup and configuration.

1. Ensure the water heater's power is turned off.
2. Loosen the two screws securing the junction box cover on the top-right side of the water heater, remove the cover, and connect the CTA module to the connection port.

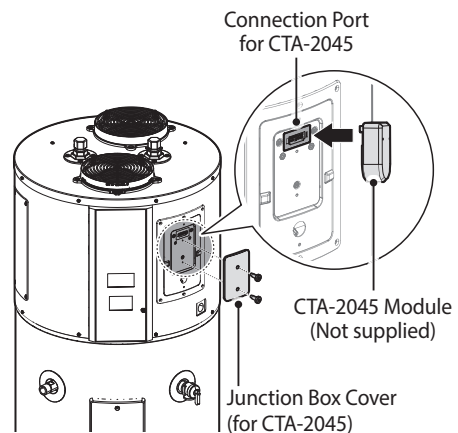

In demand response applications, a thermostatic mixing valve that complies with ASSE 1017 standard must be installed on the hot water supply line, strictly adhering to the manufacturer's installation instructions.

### 3.10 Installing the Thermostatic Mixing Valve (Optional Accessory)

When installing a thermostatic mixing valve, follow the instructions below.

1. Install a thermostatic mixing valve at each point-of-use.

#### **CAUTION**

Scalding hazards exist even when the water heater water temperature is set low, so install a thermostatic mixing valve at each point of use to reduce the risk of scalding.

2. For water heaters supplied by a solar hot water system (which is not recommended), always install a mixing valve in the water supply line to limit the water inlet temperature to 120°F (49°C). Solar hot water systems can supply water with temperatures in excess of 170°F (77°C), which is quite dangerous.

### 3.11 Installing the Shut-off Valve (Optional Accessory)

The shut-off valve automatically stops the water supply when the Navien leak detection system (optional) senses a leak, helping to prevent further leakage. The shut-off valve is not installed by default. The shut-off valve can be installed at the top or on the side, depending on the water heater's configuration.

#### **Top Installation**

1. Ensure the electrical power to the water heater is turned off.
2. Mount the shut-off valve on the top of the unit near the outlet port.
3. Cut a slit in the rubber packing to allow the shut-off valve's cable to pass through.

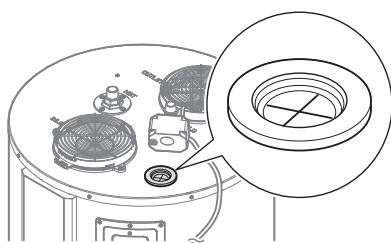

4. Remove the rubber packing from the water heater and pass the shut-off valve's cable through the hole in the packing.

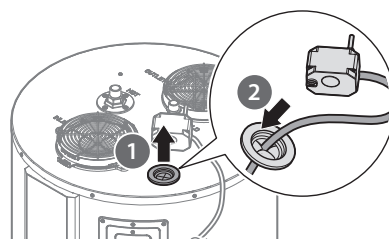

5. Fit the rubber packing into the top plate hole so that it aligns properly.
6. Remove the two screws from the bottom of the front panel, then remove it from the water heater.

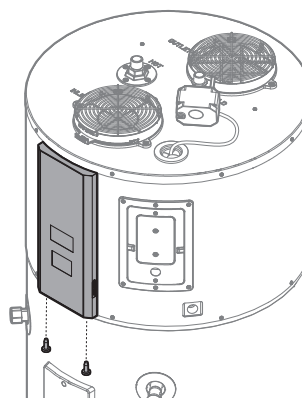

7. Disconnect the SHUT-OFF connector from the existing controller connector.

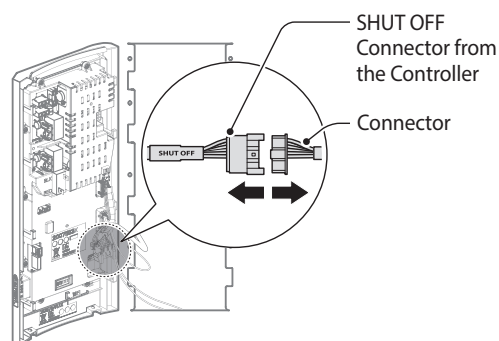

- Connect the shut-off valve's connector to the SHUT OFF connector from the controller.

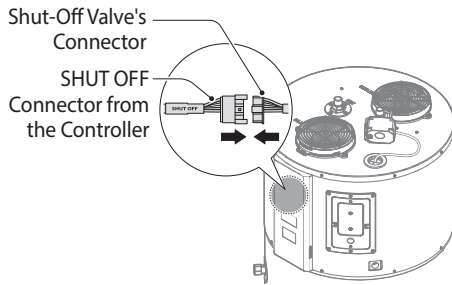

- Install the front panel and fasten it using the two screws at the bottom.

### **Side Installation**

- Ensure the electrical power to the water heater is turned off.
- Mount the shut-off valve on the side of the unit.
- Remove the two screws from the lower heating element cover, then remove it from the water heater.

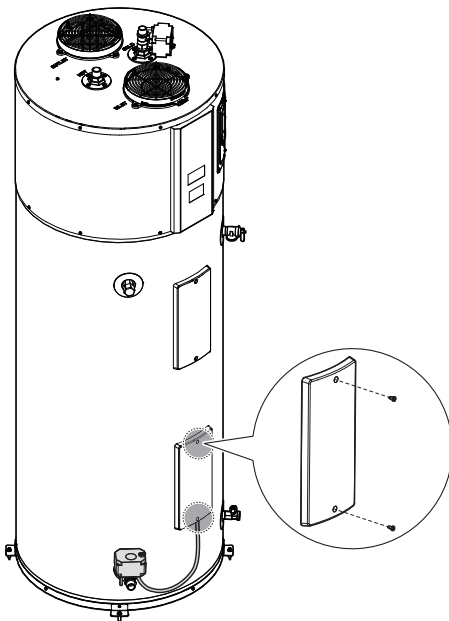

- Connect the shut-off valve's connector to the SHUT OFF connector inside the cover.

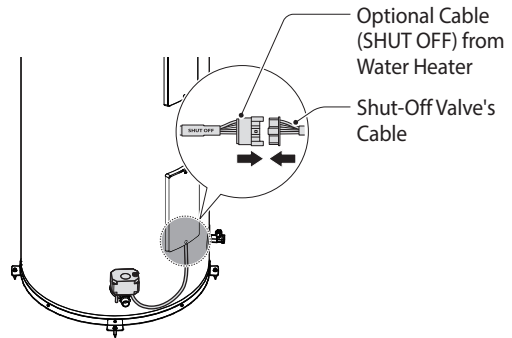

- After completing the wiring, route the cable through the opening in the lower heating element cover, then reinstall the cover on the water heater.

### **3.12 Installing the Navien Leak Detection System (Optional Accessory)**

The Navien leak detection system detects water leaks in its location and provides an alert. When a leak is detected, the front panel will display an error code, accompanied by a flashing light and an audible signal. The error code alert can also be checked via the NaviLink app. If the water heater is equipped with a shut-off valve, it will automatically close the valve to prevent further leakage.

- Ensure the electrical power to the water heater is turned off.



- Remove the two screws from the lower heating element cover, then remove it from the water heater.

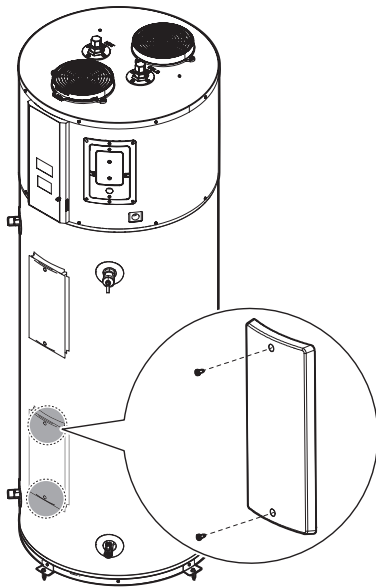

- Connect the leak detection system to the extension cable.

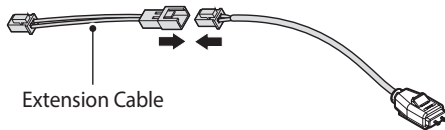

- Connect the other end of the extension cable to the LEAK cable inside the cover.

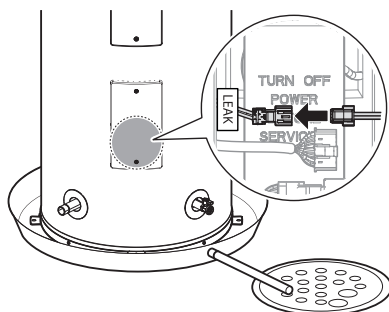

- After connecting them, route the cable through the opening in the lower heating element cover. Then reinstall the cover on the water heater.

- Attach the leak detection sensor to the side of the water heater or to the surface beneath the unit (such as the floor or the drain pan) using double-sided tape.

**Note**

- When attaching the leak detection sensor to the water heater, position it approximately 0.2 inches (5 mm) above the floor or drain pan. A malfunction error could occur if the metal probe comes into contact with another metal surface.
- For detailed information on adhesive specifications, refer to the Leak Detection Kit Guide.

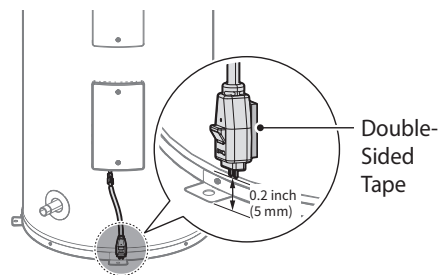

[Side of the Water Heater]

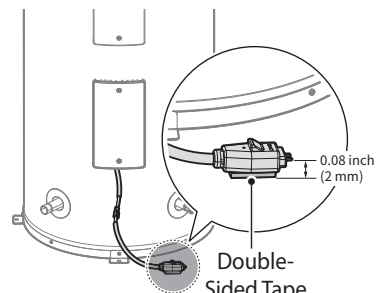

[Floor or Drain Pan]

### 3.13 Using the Navien Recirculation Pump (Optional Accessory)

#### 3.13.1 About the Navien Recirculation Pump

The Navien recirculation pump is compatible only with specific Navien products and operates by communicating with those products. Refer to the product's installation manual for more details on operation and compatibility.

#### **NOTICE**

Using a recirculation system other than the approved Navien kit may result in improper operation or system damage. Such use is not covered under Navien's Limited Warranty, which excludes damage or defects caused by unapproved recirculation systems.

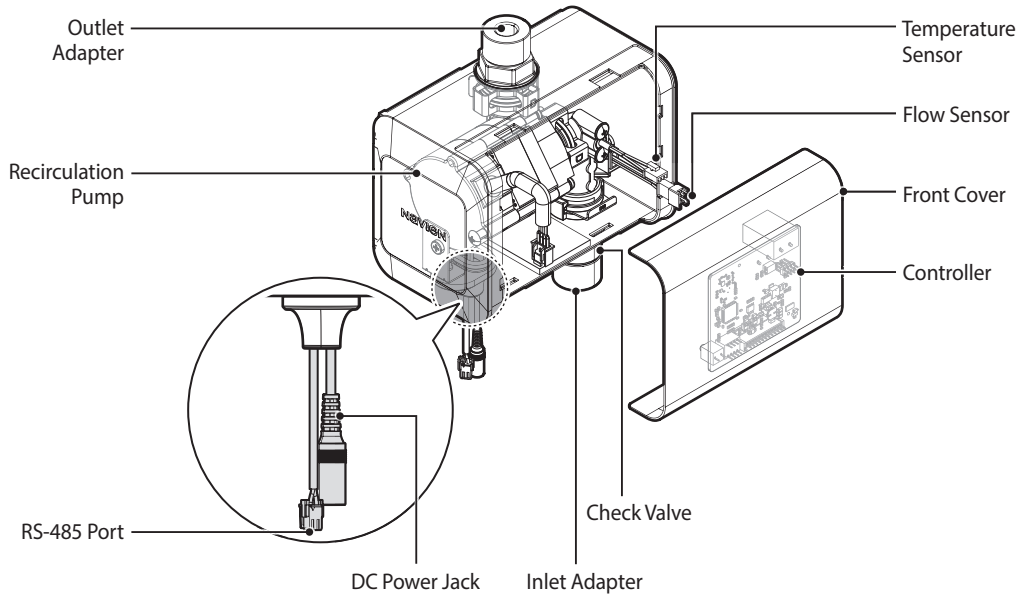

#### **Specifications**

Item	Description
Product number	30040829A
Pump head	17.7 ft
Flow rate	1.32 GPM at 15.4ft head
Power supply	24 V DC
Pump type	BLDC Pump
Operating temperature	140°F (60°C)
Operating pressure	145 psi
Flow/Temperature control	Built-in flow and temperature sensors
Pipe diameter	3/4"

### 3.13.2 Installing the Navien Recirculation Pump

The recirculation pump can be installed at the top or on the side, depending on the water heater's configuration.

**Note**

- To enable and set the recirculation mode using the front panel, refer to "5.10 Setting the Recirculation Mode" on page 53.
- The NaviCirc recirculation valve, push buttons, and temperature sensor are not included with the recirculation pump but are available for purchase separately. Refer to their respective manuals for proper usage.
- The Navien recirculation pump must be installed on the system's return line. Turn off the power to the water heater.

#### Top Installation

1. Ensure the electrical power to the water heater is turned off.
2. Refer to the standard piping diagrams to choose an appropriate location for the recirculation loop and pump.
3. Cut a slit on the rubber packing to allow the recirculation pump's communication cable to pass through.

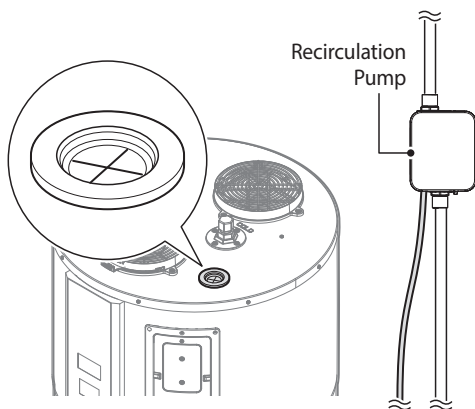

4. Take out the rubber packing and connect it to the designated point.

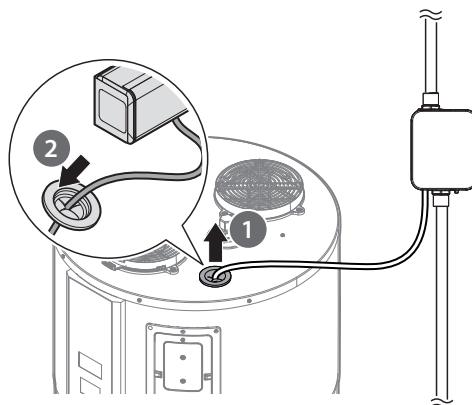

5. Fit the rubber packing into the top plate hole to align it properly.
6. Remove the 2 screws from the bottom of the front panel. Then, remove it from the water heater.

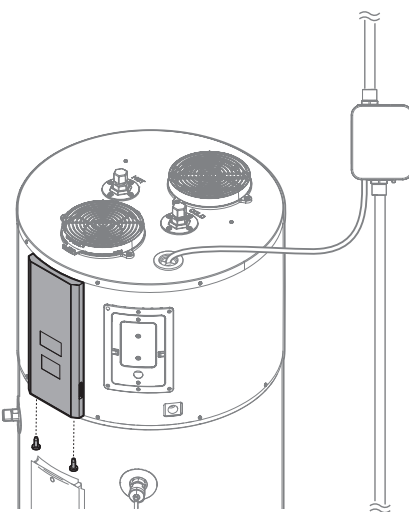

7. Disconnect the connected RE-PUMP cable from the controller.

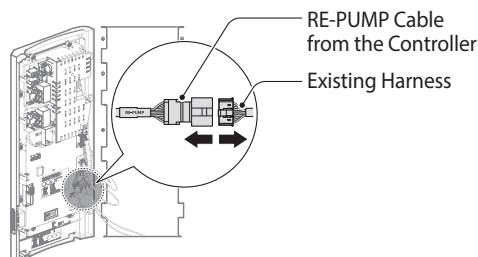

- Connect the recirculation pump's communication cable to the RE-PUMP cable from the controller. Then, use the supplied power adapter to provide power to the pump.

**Note** After connecting the connectors, ensure that all cables are secured inside the front panel.

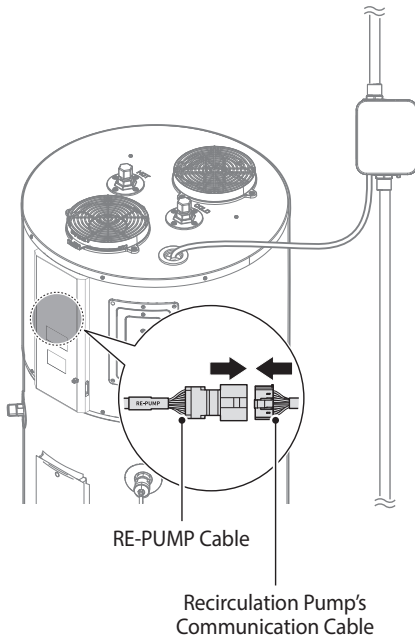

- Install the front panel and fasten it using the two screws at the bottom.
- Inspect all piping connections for leaks before turning the water heater on.

### Side Installation

- Ensure the electrical power to the water heater is turned off.
- Refer to the standard piping diagrams to choose an appropriate location for the recirculation loop and pump.

- Remove the 2 screws from the lower heating element cover. Then, remove it from the water heater.

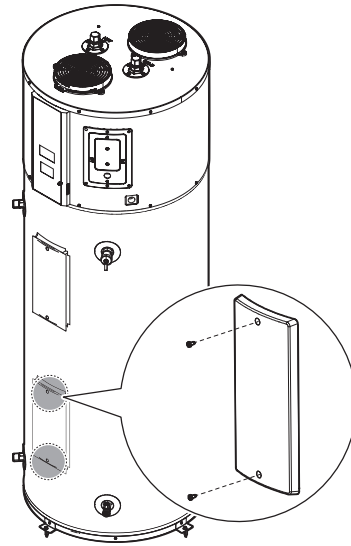

- Connect the recirculation pump's communication cable to the RE-PUMP cable from the water heater. Then, use the supplied power adapter to provide power to the pump.

**Note** After connecting the connectors, ensure that all cables are secured inside the element cover.

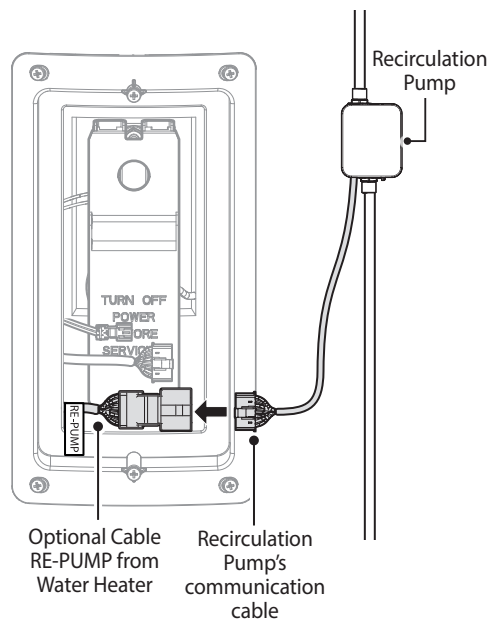

5. After connecting them, route the cable through the opening in the lower heating element cover. Then, reinstall the cover on the water heater.
6. Inspect all piping connections for leaks before turning the water heater on.

### 3.13.3 Wiring the Navien Recirculation Pump

When wiring the Navien recirculation pump, connect the temperature sensor to the **SENSOR 1** terminal and the wired push button to the **SIGNAL 2** terminal on the pump's terminal block.

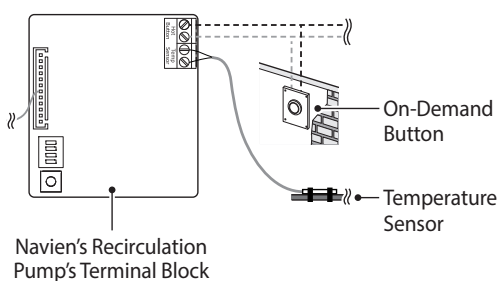

### 3.13.4.1 Examples of External Recirculation Systems

#### **NOTICE**

The return water pipe must be connected to the cold water inlet side; otherwise, it may cause improper circulation, backflow of hot water, and reduce system efficiency and safety.

### 3.13.4 Configuring the External Recirculation System

The external recirculation system enables hot water to circulate continuously or on demand, reducing the time it takes for hot water to reach fixtures. This setup typically requires a recirculation loop, which may be configured using a dedicated return line or a crossover valve, depending on plumbing layout and site conditions.

#### **Note**

- Provide adequate insulation for the loop to prevent the water heater from running continuously.
- Adding a recirculation system to the heat pump water heater can make the water heater operate more frequently.

## Top Inlet and Outlet Connections with a Return Line

- When using the top inlet and outlet only

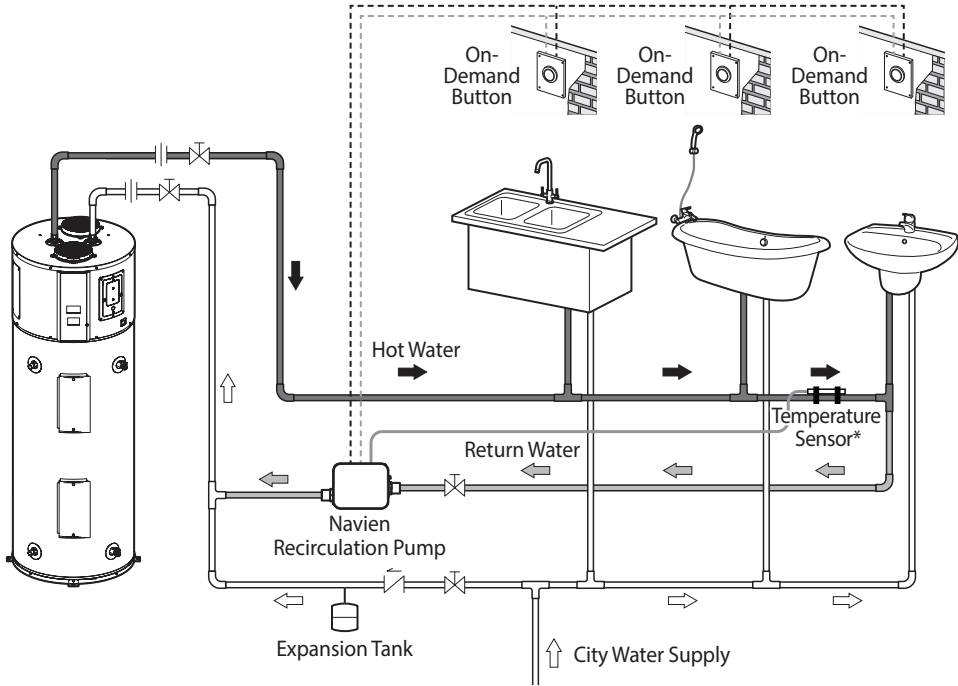

- When using the optional side inlet for the return line

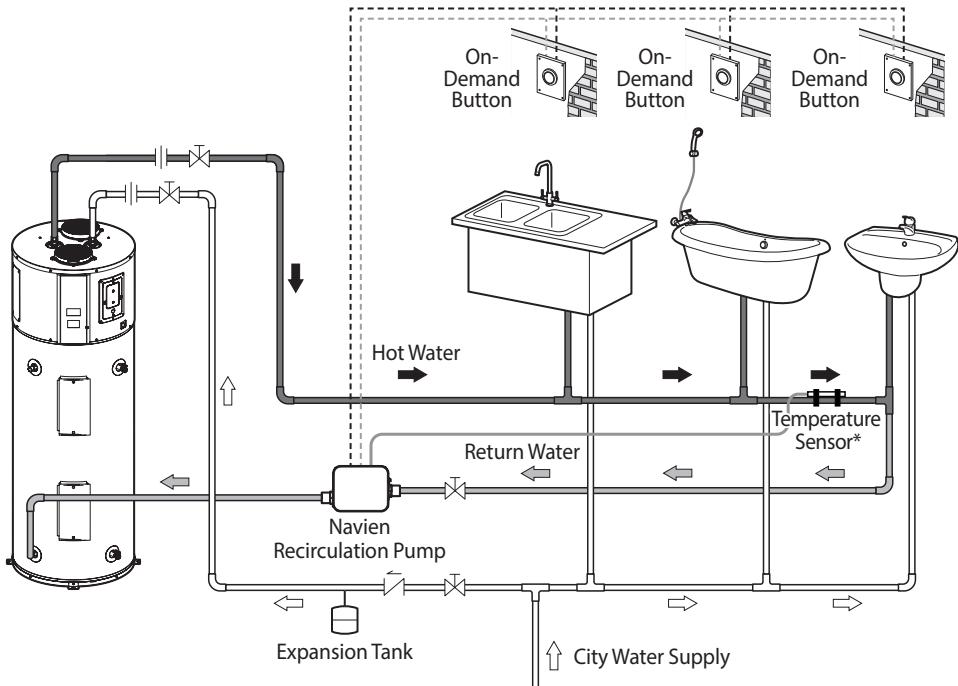

## Side Inlet and Outlet Connections with a Return Line

- When using the side inlet and outlet only

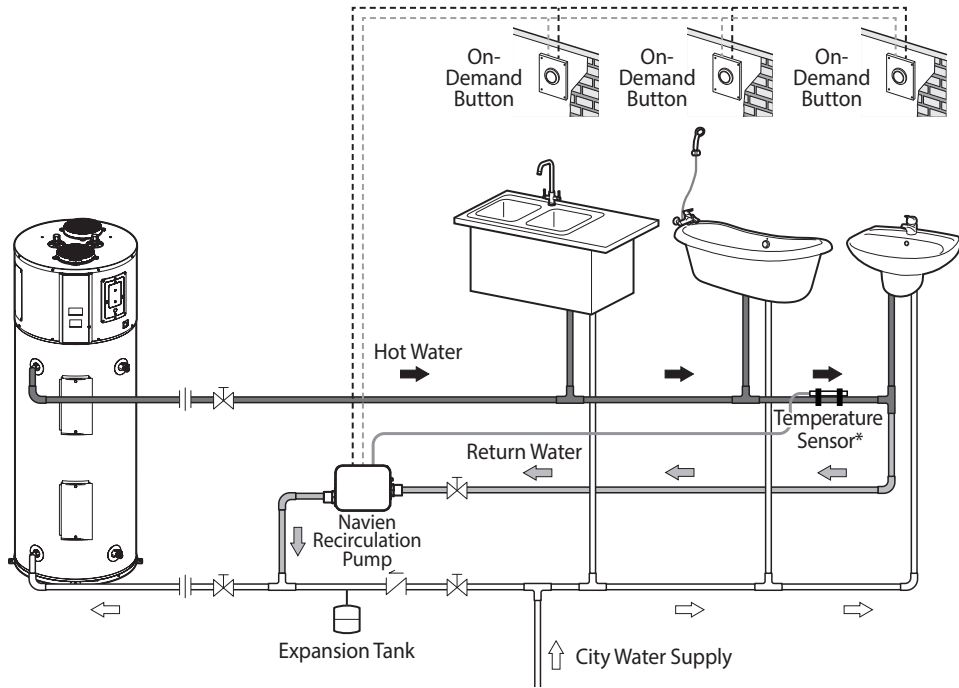

- When using the top inlet for the return line

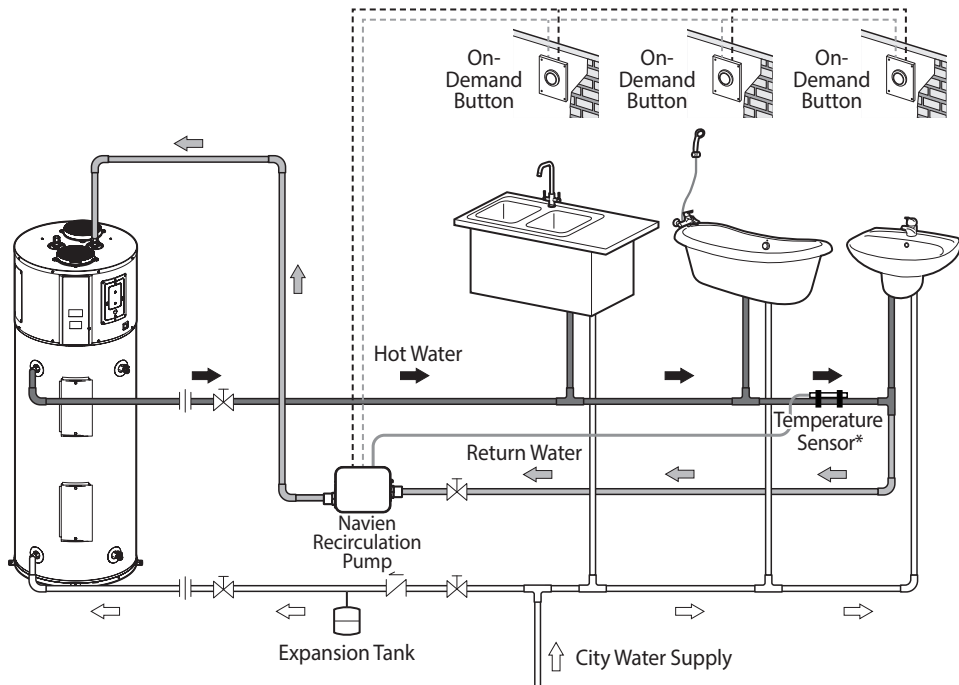

## Top Inlet and Outlet Connections with Navien NaviCirc

- When using the top inlet and outlet only

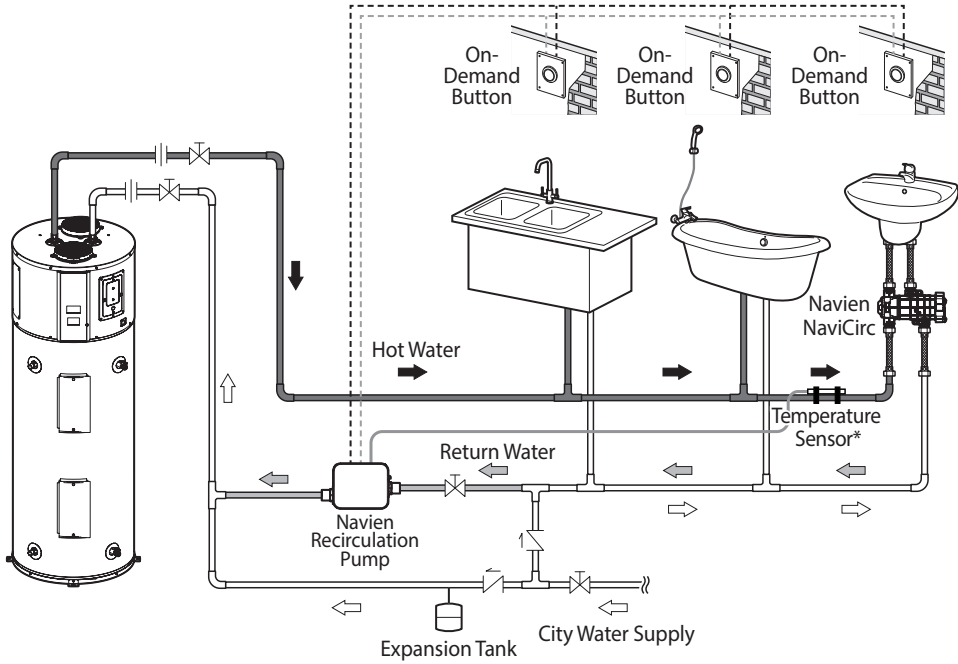

- When using the optional side inlet for the return line

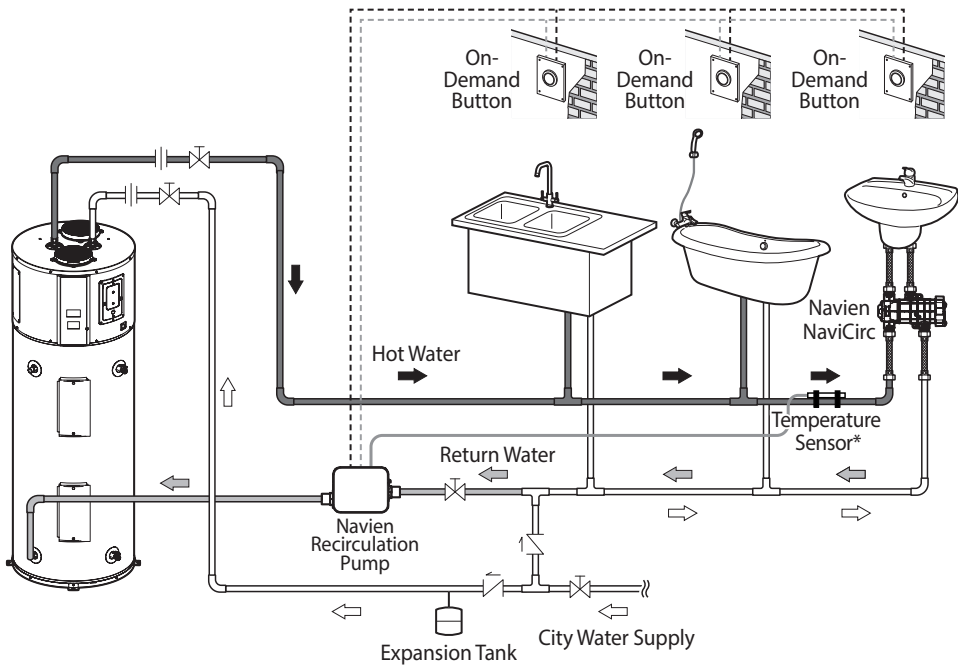



## Side Inlet and Outlet Connections with Navien NaviCirc

- When using the side inlet and outlet only

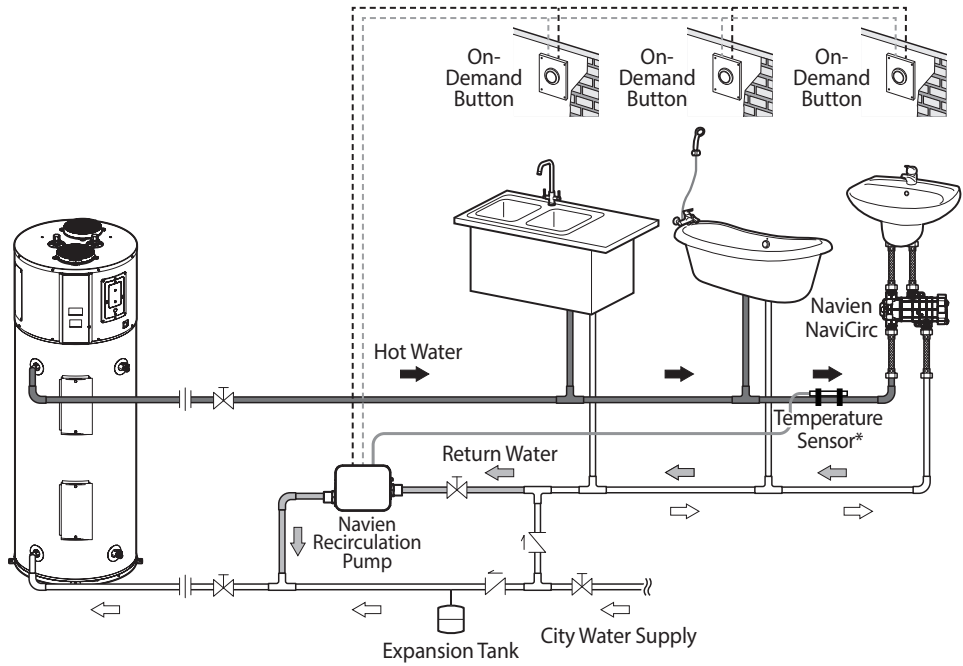

- When using the top inlet for the return line

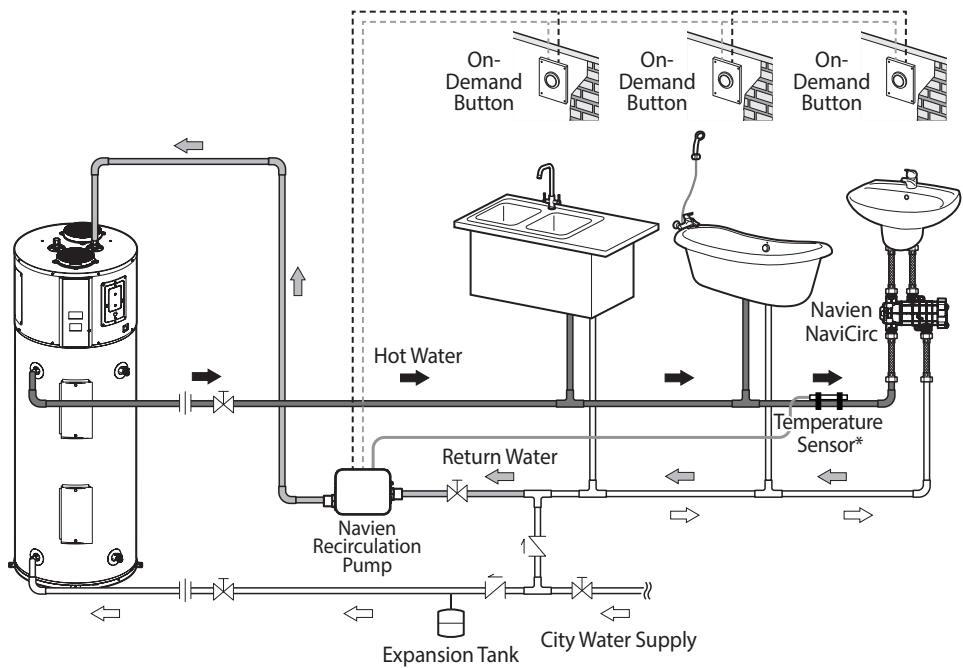

\* For Eco Recirculation Mode only

## 4. Installation Check List

After installing the water heater, review the following checklist. You should be able to answer “Yes” to all of the items in the checklist. If not, review the appropriate sections to complete installation. To troubleshoot any operational problems, refer to “7. Troubleshooting” on page 71.

If you have additional questions or need assistance with installation, contact Technical Support at 1-800-519-8794 or 1-949-420-0420, or refer to the technical support section of Navien’s website ([www.navieninc.com](http://www.navieninc.com)).

Water Heater Location	Yes	No
Close to start of hot water piping		
Indoors and protected from moisture, wet conditions, freezing temperatures and high temperatures		
No flammable vapors		
Provisions for air circulation		
Regulations followed so area is protected from water damage		
Enough space to service the water heater		
Enough space to perform maintenance on the Intake filter		
Enough space to perform maintenance on condensate		
Vibration isolation kit installed (non-concrete floor)		
Earthquake kit installed (if required)		

Water Supply	Yes	No
The water heater is completely filled with water		
Air in the water heater and piping has been purged		
Water supply lines are tight and free of leaks		
Flexible water connections (if required)		

Temperature and Pressure (T&P) Relief Valve	Yes	No
Temperature & pressure (TP) relief valve properly installed and discharge line runs to open drain		
Discharge line protected from freezing		

Wiring	Yes	No
Power supply voltage matches the rating plate on the water heater		
Branch circuit wire and fusing or circuit breaker is the proper size (30 ampere)		
Electrical connections are tight and unit properly grounded		
The power connection wire used is 10 gauge or thicker		

<b>Condensate Lines</b>	<b>Yes</b>	<b>No</b>
Condensate lines from the water heater are installed correctly		
Condensate lines from the water heater run to a suitable drain location		

<b>Ducting</b>	<b>Yes</b>	<b>No</b>
HVAC approved ducting		
Calculated length of duct no greater than maximum allowed		
UL certified terminations (for ducting to the outside)		
Insulated duct		
Ducting adequately supported		
Ducting adequately isolated from structure		

<b>Shut Off Valve (Optional)</b>	<b>Yes</b>	<b>No</b>
Make sure the valve is open		

<b>Navien Leak Detection System (Optional Accessory)</b>	<b>Yes</b>	<b>No</b>
Make sure the sensor is dry and does not touch water during installation		

<b>Battery</b>	<b>Yes</b>	<b>No</b>
Make sure the battery protection film is removed		

## 5. Operating the Water Heater

### **⚠ WARNING**

If the water heater was transported horizontally, do not power it on immediately. Allow the unit to stand upright for at least 24 hours before operation. Failure to do so may cause compressor damage and reduced system efficiency due to improper oil distribution.

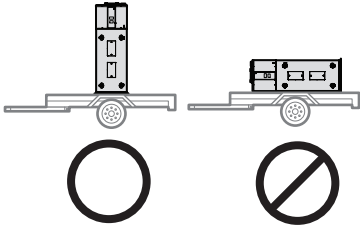

### **NOTICE**

Do not turn on the water heater without ensuring that all air has been purged from the tank and that the tank is completely filled with water. This water heater is equipped with a “Dry Fire” protection function that detects if the tank is not fully filled with water at the initial power connection. However, if the heating element operates when the tank is empty, there is a risk of fire or electric shock. Therefore, before turning on the water heater, ensure the tank is filled with water and all air is removed. The “Dry Fire” protection function operates only at the initial power connection.

### 5.1 Turning the Water Heater On or Off

To turn the water heater on or off, press the Power button.

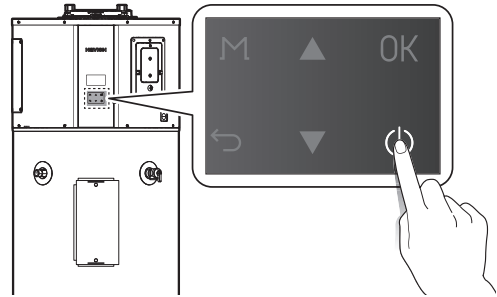

When the power is turned on, the product performs the Self Diagnostic operation. (This operation is performed each time the power is turned on after being in an unpowered state.)

The Self Diagnostic process takes approximately 10 minutes, during which the front panel will display [Self Diagnostic in Progress].

If an issue is detected during the Self Diagnostic process, an error code will be displayed. If the error is one that prevents the product from operating, the product will remain in a stopped state until the issue is resolved.

### **⚠ WARNING**

Do not disconnect the power from the product during the Self Diagnostic operation. Disconnecting the power during the Self Diagnostic process may damage the product. Additionally, if the power is disconnected and then turned on, the Self Diagnostic process will start again from the beginning.

## 5.2 Start-Up Wizard

The setup wizard should run the first time the unit is powered on. The wizard must be completed before the water heater can be used.

When the setup wizard is displayed after turning on the water heater first time, press the Up (▲) or Down button (▼) to scroll through the items in the Start-Up Wizard, and then, press the OK button (OK) to confirm and continue. To return to the setup wizard menu, press the Back button (↶).

1. Set the time.
  - YYYY.MM.DD HH:MM:SS
2. Set the units to display.
  - °F
  - °C
3. Accessories Check
  - Leak Detection System: Installed / Not installed
4. Water Fill Tank
  - A description of the water fill tank is displayed.
5. Operation Mode
  - Select the operation mode.
6. Tank Setting Temperature
  - Setting Range: 95°F (35°C)–150°F (65.5°C)
  - Default: 120°F (49°C)
7. Wi-Fi Setting
  - Follow the instructions to configure the Wi-Fi settings.
8. Eco Port Setting
  - Follow the instructions to configure the Eco Port settings.
9. Setup Summary
  - Once the Setup Wizard is finished, a summary of the settings will be displayed. Press the OK button (OK) at each summary screen until the main screen is displayed.

## 5.3 Selecting the Operation Mode & Adjusting Water Temperature

After the 10-minute Self Diagnostic mode is completed, the product will enter Idle mode.

You can select the desired operation mode according to your preferences or usage environment. For a description of each mode, refer to “5.4 About Operating Modes” on page 46.

The same tank temperature can be set for all provided operation modes. The setting range is from the set minimum operation temperature to 150°F (65.5°C). If it is set to 120°F (49°C) or higher, [Scald Risk] will be displayed on the front panel.

### **⚠ WARNING**

Before adjusting the water temperature, read “To prevent burns:” on page 5 carefully. Water above 120 °F can cause instant scalding, severe burns, or death.

The water heater is set to 120°F (49°C) by default. To adjust the water temperature:

1. Make sure that all hot water faucets are closed.
2. Press the Up (▲) or Down button (▼) until the desired temperature appears on the display. You can adjust the temperature while the display is flashing. Once the display stops flashing, the temperature setting is stored.

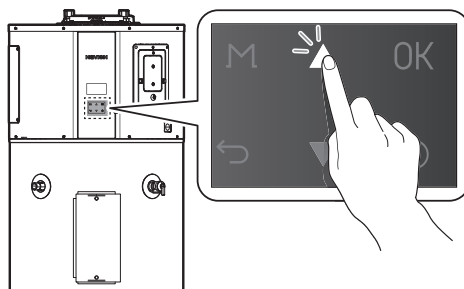

### **Note**

The water heater will retain your settings during a power outage.

You can adjust the temperature by 1 degree increments as shown below, depending on the temperature range:

Temperature Range	Temperature Increment
[Min. operation Temp.]–150°F (65.5°C)	1°F or 0.5°C increments

**Note** The minimum operation temperature can be set from 95°F (35°C) to 113°F (45°C), with a default setting of 95°F (35°C). To adjust this setting, refer to “Setting the Protection Function” on page 57.

## 5.4 About Operating Modes

### 5.4.1 Energy Saver (Hybrid: Efficiency) – Default

This mode combines the heat pump and electric heater (heating element) as the heat source to heat the tank. The heat pump is primarily used to enhance energy efficiency, while the electric heater is used to reduce the recovery time. This mode is the default operating mode applied during initial shipment and factory reset.

### 5.4.2 High Demand (Hybrid: Boost)

This mode controls the tank’s heating by combining the heat pump and electric heater (heating element). The electric heater is used more frequently than when it is in the Energy Saver mode to further shorten the recovery time. This mode is set when a higher supply of hot water is desired.

### 5.4.3 Heat Pump

This mode controls the heating of the tank using only the heat pump as the heat source. It is the most energy-efficient mode among the available operating modes, but it also has the longest recovery time. When operating solely with the heat pump, the energy efficiency and recovery time may vary depending on the ambient temperature and relative humidity (the higher the ambient temperature and relative humidity, the greater the energy efficiency and the shorter the recovery time).

### 5.4.4 Electric

This mode controls the heating of the tank using only the electric heater (upper and lower). It is the least energy-efficient mode, but it offers the shortest recovery time. When this mode is set, it can be used continuously for up to 72 hours (3 days), after which it will automatically return to the previous operating mode. (The upper and lower heaters do not operate simultaneously.)

### 5.4.5 Vacation - Default: OFF

This mode is provided to prevent unnecessary tank heating operations during vacations or long absences. The number of days for the Vacation mode can be set from **0 days (OFF) to 1 to 99 days**. When this mode is set, the tank heating operation is suspended for the set number of days, and only minimal operations (such as freeze protection and anti-seize) are performed to protect the product. However, 9 hours before the set number of days is reached, the mode automatically reverts to the previous operating mode and performs tank heating operations until the set temperature is reached.

Mode	Efficiency	Recovery
Electric	Very Low	Fast
Heat Pump	High	Very Slow
High Demand	Low	Very Fast
Energy Saver	Very High	Fast
Vacation	Very High	None

## 5.5 Setting Operation Schedules and Configuring Communication Settings

You can set the water heater's operation for vacation and configure the weekly operation schedule and communication settings to customize the water heater's operation based on your needs.

1. Press and hold the Menu button (M) for more than 5 seconds, and then select **Setting**.

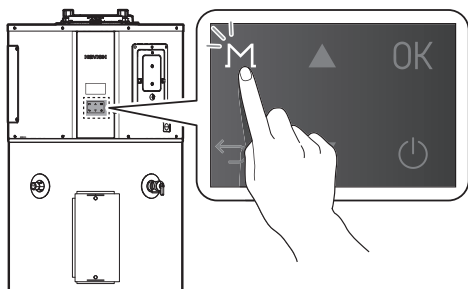

### Main Menu

1. Setting
2. Status Information
3. System Information
4. Error History

2. Press the Up (▲) or Down button (▼) to scroll through the items. Press the OK button (OK) to select an item.

Item	Description
1. Vacation	Set the vacation period. • Setting range: 0 Day (Off), 1–99 Days • Default: 0 Day
2. Schedule	Set the weekly operation schedule.
3. Communication	Enable or disable the Wi-Fi and DR communication. 1. Wi-Fi • Setting range: On, Off • Default: Off 2. DR • Setting range: On, Off • Default: Off 3. Eco Port • Setting range: On, Off • Default: Off

Item	Description
4. Air Filter Alarm Reset	Set the air filter replacement alarm reset. • Setting range : Yes, No • Default : No

3. Press the Back button (↶) to return to the previous screen or menu.

### 5.5.1 Setting the Weekly Operation Schedule

You can schedule the weekly operation and view the weekly operation schedule list.

1. From the Setting Menu, select **Schedule**.

#### 1. Setting

1. Vacation
2. Schedule
3. Communication
4. Air Filter Alarm Reset

2. Press the Up (▲) or Down button (▼) to scroll through the items, and set the weekly operation schedule details.

Item	Description
1. Weekly Enable	Enable or disable the weekly operation schedule. • Setting range: On, Off • Default: Off
2. Weekly Set	Set the weekly operation schedule.
3. Weekly List	View the list of weekly operation schedules.
4. Weekly Delete	Delete the weekly operation schedule.

3. Press the Back button (↶) to return to the previous screen or menu.

## Setting Weekly Operation Schedule

### Details

- From the Schedule menu, select **Weekly Set**.
- Press the Up (▲) or Down button (▼) to scroll through information items. Press the OK button (OK) to select a sub menu of parameters and then set the schedule details.

Item	Description
Day	<p>Set the days for the water heater to operate. You can select multiple days for operation.</p> <ol style="list-style-type: none"> <li>Press the OK button (OK) to select the day of the week. <ul style="list-style-type: none"> <li>Setting range: Sun, Mon, Tue, Wed, Thurs, Fri, Sat</li> </ul> </li> <li>Press and hold the OK button (OK) to move to the next setting.</li> </ol>
Time	<p>Set the operating time.</p> <ol style="list-style-type: none"> <li>Press the OK button (OK) to select the time.</li> <li>Press and hold the OK button (OK) to move to the next setting.</li> </ol>
Operating Mode	Select the operating mode for selected days and time.
Temperature	Set the operating temperature.

- Press the Back button (←) to return to the previous screen or menu.

### Viewing the Weekly Schedule List

Once the weekly operation schedule is created, you can view the weekly schedule list.

- From the Schedule menu, select **Weekly List**.
- Press the Up (▲) or Down button (▼) to scroll through schedule items, and select an item to view its schedule information.

### 3. Weekly List

- E-SAVER, 8:11, 95°F
- IDLE, 15:39, 102 °F
- ELECTRIC, 22:42, 120°F

S M T W T F S

The set operation mode, time, and temperature will be displayed, while the selected days on the weekly schedule will be indicated at the bottom of the screen.

### Deleting Weekly Operation Schedules

- From the Schedule menu, select **Weekly List**.
- From the set weekly operation schedules on the list, press the Up (▲) or Down button (▼) to select a schedule item to delete, and then, press the OK (OK) button.

### 4. Weekly Delete

- E-SAVER, 8:11, 95°F
- IDLE, 15:39, 102 °F
- ELECTRIC, 22:42, 120°F

S M T W T F S

- From the Weekly Delete screen, press the Up (▲) or Down button (▼) to select **Yes**, and then press the OK (OK) button to delete the selected schedule item. If you do not want to delete it, select **No**.

### 4. Weekly Delete

Yes

No



## 5.6 Viewing Status Information

You can view operating status information, including, hot water, heat pump, and heating element.

1. Press and hold the Menu button (M) for more than 5 seconds and then select **Status Information**.

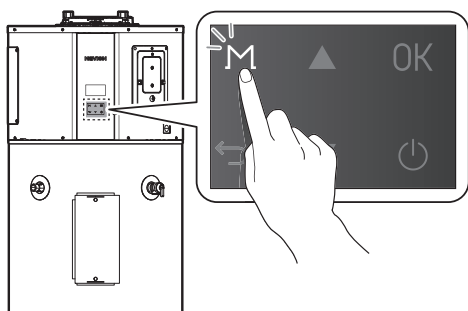

Main Menu	
1. Setting	
2. Status Information	
3. System Information	
4. Error History	

2. Press the Up (▲) or Down button (▼) to scroll through information items. Press the OK button (OK) to select an item to view the information.

Item	Description
1. Hot Water	Temperature of the pump, hot water temperature, and water flow rate
2. Heat Pump	Heat pump module's operating information
3. Heating Element	Heating element's operating information
4. Recirc Pump	Recirculation pump kit's operating information

3. Press the Back button (↶) to return to the previous screen or menu.

### 5.6.1 Viewing the Hot Water Information

1. From the Status Information Menu, Select **Hot Water**.

2. Status Information	
1. Hot Water	
2. Heat Pump	
3. Heating Element	
4. Recirc Pump	

2. Press the Up (▲) or Down button (▼) to scroll through information items. Press the OK button (OK) to select an item to view the information.

Item	Description
1. Tank Upper Temp	Current upper temperature of the tank (°F/°C)
2. Tank Lower Temp	Current lower temperature of the tank (°F/°C)

3. Press the Back button (↶) to return to the previous screen or menu.

## 5.6.2 Viewing the Heat Pump Information

1. From the Status Information Menu, Select **Heat Pump**.

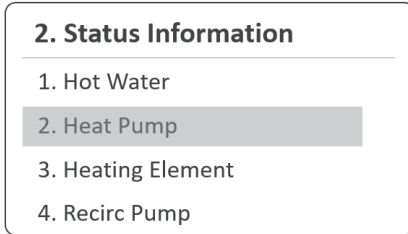

2. Press the Up (▲) or Down button (▼) to scroll through information items. Press the OK button (OK) to select an item to view the information.

Item	Description
1. Compressor On/Off	Current operating status of the compressor (On or Off)
2. Discharge Temp	Current discharge temperature (°F/°C)
3. Suction Temp	Current suction temperature (°F/°C)
4. Evaporate Temp	Current evaporate temperature (°F/°C)
5. Ambient Temp	Current ambient temperature (°F/°C)
6. Evaporate Fan Speed	Current evaporator fan speed (RPM)
7. Current Super Heat	Current super heat temperature (Δ°F/Δ°C)
8. EEV Step	Valve opening rate (%) of the electronic expansion valve (EEV)

3. Press the Back button (↶) to return to the previous screen or menu.

## 5.6.3 Viewing the Heating Element Information

1. From the Status Information Menu, select **Heating Element**.

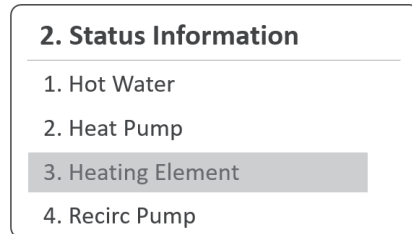

2. Press the Up (▲) or Down button (▼) to scroll through information items. Press the OK button (OK) to select an item to view the information.

Item	Description
1. UHE Output	Current operating status of the upper heating element (On or Off)
2. LHE Output	Current operating status of the lower heating element (On or Off)

3. Press the Back button (↶) to return to the previous screen or menu.

## 5.6.4 Viewing the Recirculation Pump Kit Information

1. From the Status Information Menu, select **Recirc Pump**.

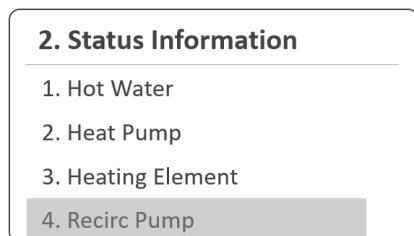

2. Press the Up (▲) or Down button (▼) to scroll through information items. Press the OK button (OK) to select an item to view the information.

Item	Description
1. Recirc Temperature	Current recirculation pump return water temp (°F/°C)
2. Recirc Flow Rate	Current recirculation pump water flow rate (GPM/LPM)

3. Press the Back button (↶) to return to the previous screen or menu.

## 5.7 Viewing System Information

You can view the system information, including tank capacity, product category, and Wi-Fi connection status.

1. Press and hold the Menu button (M) for more than 5 seconds and then select **System Information**.

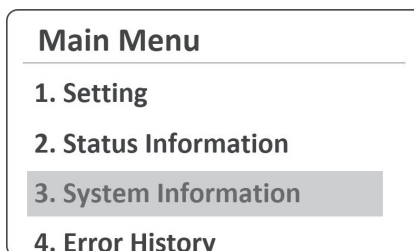
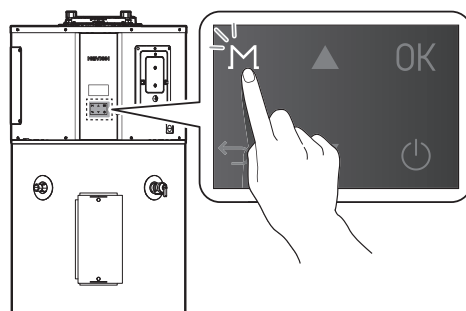

2. Press the Up (▲) or Down button (▼) to scroll through information items. Press the OK button (OK) to select an item to view the information.

Item	Description
1. Tank Capacity	Set tank capacity (50 Gallon, 65 Gallon or 80 Gallon)
2. Product Category	Set product's category (Standard, Premium or Plug-in)
3. Wi-Fi Connection	Wi-Fi Connection status (Connect or Disconnect)
4. Date/Time	Current date and time
5. RTC Battery	Current voltage of the RTC battery
6. F/W Version	Firmware version of the controller

3. Press the Back button (↩) to return to the previous screen or menu.

## 5.8 Viewing Error History

You can view a list of recent errors and check for details. For more information about the error codes, refer to “7.2 Understanding Error Codes” on page 73.

1. Press and hold the Menu button (M) for more than 5 seconds and then select **Error History**.

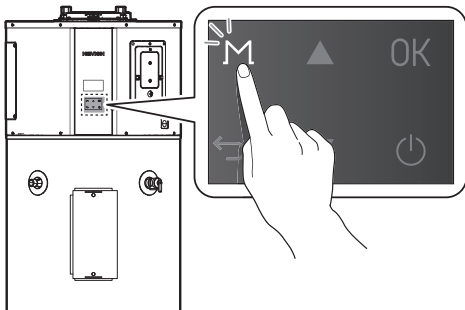

### Main Menu

---

1. Setting
2. Status Information
3. System Information
4. Error History

A list of 10 recent errors are displayed on the screen, with the most recent error displayed at the top of the list.

### 4. Error History

---

1. Error 096 - 00
2. Error 326 - 00
3. Error 481 - 00
4. Error 901 - 00

2. Press the Up (▲) or Down button (▼) to scroll through the list of errors. Press the OK button (OK) to select an error to view the detailed information.

### 1. Error 096 - 00

---

**Abnormal Heat Element**

**Check Heat Element**

**2020-01-02 08:34:05**

3. Press the Back button (↩) to return to the previous screen or menu.

#### Note

- The front panel display flashes in red and the error icon is displayed (flashing) when a level 1 error is detected. You can press the OK button (OK) to enter error display mode. The operation is maintained during a level 1 error.
- Level 1 errors are automatically cleared when the problem is resolved.
- You can press the Back button (↩) to clear a level 1 error. The error is then cleared if the problem has been resolved.
- You can press and hold the Back button (↩) for 5 seconds to clear a level 1 error. The error is then cleared if the problem has been solved.

## 5.9 Viewing Other System Operation Information

You can view system operation information, including heat pump operation time, heating element operation time, and power consumption."

1. Press and hold the Menu button (M) for more than 5 seconds and then select **EMS Data**.

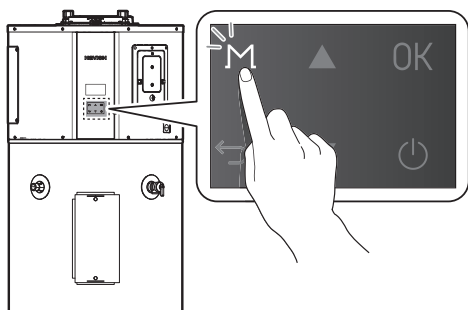

Main Menu	
2. Status Information	
3. System Information	
4. Error History	
5. EMS Data	

2. Press the Up (▲) or Down button (▼) to scroll through information items. Press the OK button (OK) to select an item to view the information.

Item	Description
1. HP Operation Time	Monthly heat pump operating time
2. HE Operation Time	Monthly heating element operating time
3. Power Consumption	Monthly power consumption

3. Press the Back button (↶) to return to the previous screen or menu.

## 5.10 Setting the Recirculation Mode

You can customize the water heater's operation by enabling the preheating function in the recirculation mode to match your lifestyle.

1. Press and hold the Menu button (M) for at least 5 seconds, and then select **Recirculation Settings**.

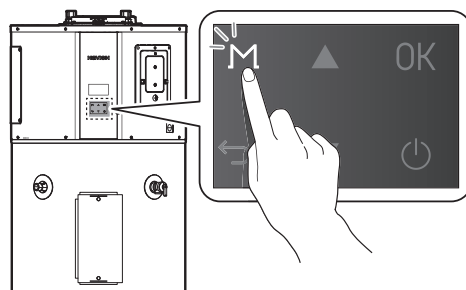

Main Menu	
4. Error History	
5. EMS Data	
6. Configuration	
7. Recirculation Settings	

2. Press the Up (▲) or Down button (▼) to scroll through the items. Press the OK button (OK) to select an item.

Item	Description
1. Always On	Run continuous domestic hot water (DHW) recirculation.
2. Weekly	Schedule the weekly recirculation operation.
3. HotButton Only(Manual)	Manually activate a one-time DHW recirculation cycle using an external HotButton or the Navilink app.

3. Press the Back button (↶) to return to the previous screen or menu.

### 5.10.1 Setting the Recirculation Weekly Operation Schedule

You can set and review a weekly recirculation schedule.

- From the Recirculation Settings Menu, select **Weekly**.

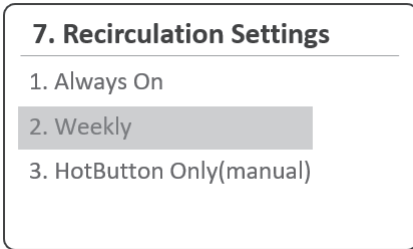

- Press the Up (▲) or Down button (▼) to scroll through the items, and set the weekly operation schedule details.

Item	Description
1. Weekly Enable	Turn the weekly recirculation schedule On or Off (Default: Off).
2. Weekly Set	Create or modify the weekly recirculation schedule.
3. Weekly List	View all saved weekly recirculation schedules.
4. Weekly Delete	Remove a weekly recirculation schedule.

- Press the Back button (↩) to return to the previous screen or menu.

### Setting Weekly Recirculation Operation Schedule Details

- From the Weekly Menu, select **Weekly Set**.
- Press the Up (▲) or Down button (▼) to scroll through items. Press the OK button (OK) to select a sub menu of parameters, then set the schedule details.

Item	Description
Day	Set the days for the recirculation to operate. Multiple days can be chosen. 1. Press the OK button(OK)to select a day of the week. <ul style="list-style-type: none"> <li>Setting range: Sun, Mon, Tue, Wed, Thu, Fri, Sat</li> </ul> 2. Press and hold the OK button(OK)to move to the next setting.
Time	Set the operating time. 1. Press the OK button (OK) to select the time. 2. Press and hold the OK button(OK)to move to the next setting.
Operation	Select the recirculation On or Off for selected days and time.

## Viewing the weekly schedule list

1. From the Weekly Menu, select **Weekly List**.
2. Press the Up (▲) or Down button (▼) to scroll through schedule items, and select an item to view its details.

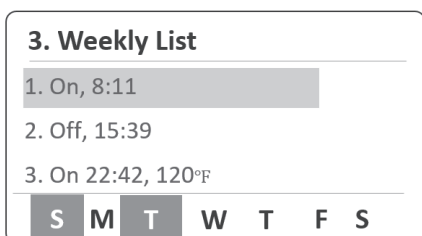

The programmed On and Off time will be displayed, and the selected days in the weekly schedule will appear at the bottom of the screen.

## Deleting Weekly Recirculation Operation Schedules

1. From the Weekly Menu, select **Weekly Delete**.
2. From the list, press the Up (▲) or Down button (▼) to select a schedule item to delete. Then, press the OK (OK) button.

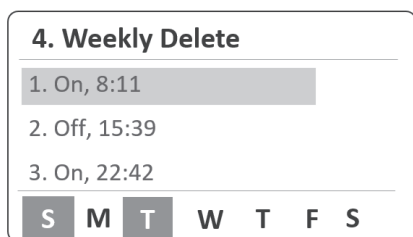

3. From the Weekly Delete screen, press the Up (▲) or Down button (▼) to select **Yes**, then press the OK (OK) button to delete the selected schedule item. To cancel, select No.

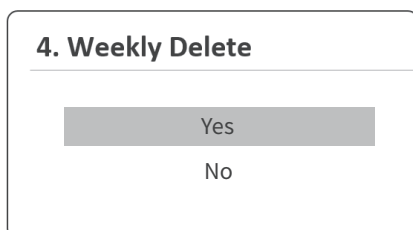

## 5.11 Configuring the Installer Settings

You can configure detailed operation settings for service, reset all settings, or change the installer menu password.

1. Press and hold the Menu button (M) and the Back button (↶) simultaneously for more than 5 seconds, and then select **1. Installer Menu**.

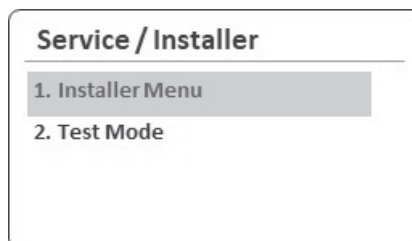
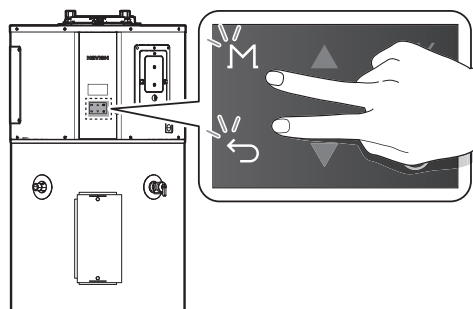

2. On the Password screen, use the Up (▲) or Down button (▼) to change numbers and OK (OK) button to move to the next digit. Press OK (OK) button after entering all four digits to confirm the password. If the password is correct, the Installer Menu will be displayed.

**Note** The factory default password is "1234."

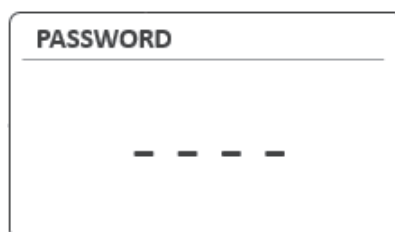

- Press the Up (▲) or Down button (▼) to scroll through information items. Press the OK button (OK) to set the configuration.

Item	Description
1. Service Wizard	Perform system checks.
2. Parameter Settings	Set the water heater parameters.
3. Factory Reset	Initialize all parameter settings (panel and controller).
4. P/W Change	Change the Installer Menu password.

**Note**

- If you enter an incorrect password 10 times or make no input for 1 minute, the water heater will return to Normal mode.
- To return to the previous mode, press the Back button (↩).

- Press the Back button (↩) to return to the previous screen or menu.

### 5.11.1 Service Wizard

From the Installer Menu menu, select **Service Wizard**. When you enter the Service Wizard screen, the water heater will perform a self-check process on the following items.

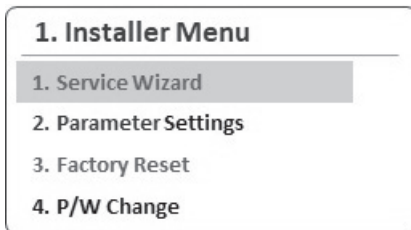

Item	Description
1. Fill Water Check	Operate Dry Fire protection.
2. Heating Element Check	Check the status of the upper and lower heating elements.
3. Evaporator Fan Check	Check if the evaporator fan is operating normally.

Item	Description
4. Leak Detection System Check	Operate the shut-off valve to full open or full close and check the opening (or closing) rate.
5. Heat Pump Unit Check	Check the remaining time and process status by manually operating the heat pump module.

### 5.11.2 Setting the Operation Parameters

- From the Installer Menu, select **Parameter Settings**.

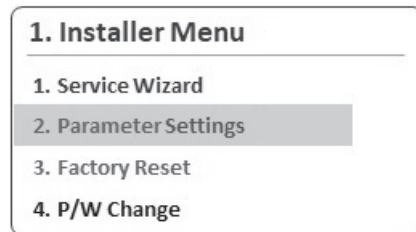

- Press the Up (▲) or Down button (▼) to scroll through the items. Press the OK button (OK) to select a sub menu of parameter.

Item	Description
1. Protection Setting	Set the protection setting.
2. Option	Set the operation parameters.

- Press the Back button (↩) to return to the previous screen or menu.



## Setting the Protection Function

- From the Parameter Settings menu, select **Protection Setting**.

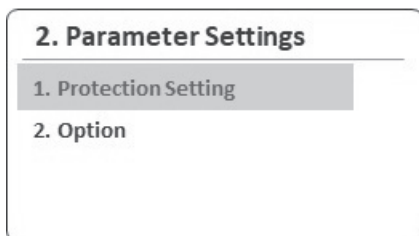

- Press the Up (▲) or Down button (▼) to scroll through the parameters or to increase or decrease setting values. Press the OK button (OK) to select a Protection Setting parameter or confirm a change.

Item	Description
1. Freeze Protection Temp	Set the freeze prevention temperature. <ul style="list-style-type: none"> <li>Setting range: 43°F (6°C)–50°F (10°C)</li> <li>Default: 43°F (6°C)</li> </ul>
2. Min Operation Temp	Set the minimum heat pump operation temperature. <ul style="list-style-type: none"> <li>Setting range: 95°F (35°C)–113°F (45°C)</li> <li>Default: 95°F (35°C)</li> </ul>
3. Anti-Legionella Use	Enable or disable the anti-legionella function. <ul style="list-style-type: none"> <li>Setting range: On, Off</li> <li>Default: Off</li> </ul>
4. Anti-Legionella Cycle	Set the anti-legionella operation cycle. <ul style="list-style-type: none"> <li>Setting range: 1–30 Days</li> <li>Default: 7 Days</li> </ul>
5. Air Filter Alarm Cycle	Set the air filter replacement alarm cycle. <ul style="list-style-type: none"> <li>Setting range: Off or 1,000–10,000 Hours</li> <li>Default: 1,000 Hours</li> </ul>

**Note** If you make no input for 10 seconds in the Parameter Edit mode, the current parameter value will be saved automatically.

- Press the Back button (↩) to return to the previous screen or menu.

## Setting the Valve Options

- From the Parameter Settings menu, select **Option**.

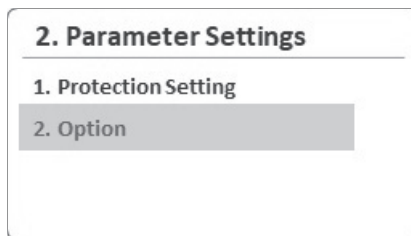

- Press the Up (▲) or Down button (▼) to scroll through parameters and adjust their settings. Press the OK button (OK) to select an option or confirm a change.

Item	Description
1. Leak Detection System	Enable or disable the leak detection system (shut-off valve) usage. <ul style="list-style-type: none"> <li>Setting range: Enable, Disable</li> <li>Default: Disable</li> </ul>
2. Ext. Mixing Valve Use	Enable or disable the external mixing valve usage. <ul style="list-style-type: none"> <li>Setting range: Enable, Disable</li> <li>Default: Disable</li> </ul>
3. Recirc Pump Kit	Enable or disable the Navien recirculation pump kit. <ul style="list-style-type: none"> <li>Setting range: Enable, Disable</li> <li>Default: Disable</li> </ul>
4. Eco Recirc Mode	Enable or disable the Eco recirculation mode. <ul style="list-style-type: none"> <li>Setting range: Enable, Disable</li> <li>Default: Disable</li> </ul>
5. Recirc Interval Time	Set the recirculation duration. <ul style="list-style-type: none"> <li>Setting range: 1–120 min</li> <li>Default: 20 Min</li> </ul> <p><b>Note</b> A default setting of 5 minutes is applied when the Eco recirculation mode is enabled</p>

Item	Description
6. Recirc Sample Time	Set the recirculation interval. <ul style="list-style-type: none"> <li>Setting range: 1–120 Min</li> <li>Default: 30 min</li> </ul>
7. Recirc Off Diff. Temp	Set the Recirculation Off offset temperature. It cannot be set when the Eco Recirc Mode is enabled. <ul style="list-style-type: none"> <li>Setting range: 5°F (3°C)–55°F (30.5°C)</li> <li>Default: 9°F (5°C)</li> </ul> <p><b>Note</b></p> <p>The recirculation temperature does not exceed 131°F (55°C).</p>
8. Fixture Distance	If the external HotButton surface temperature sensor is not used, configure the pipe length setting to define the virtual turn-off point. The internal thermostat will then be used to control recirculation. <ul style="list-style-type: none"> <li>Setting range: 15 ft (4.5 m)–660 ft (198 m)</li> <li>Default: 30 ft (9 m)</li> </ul>

**Note**

If you make no input for 10 seconds in the Parameter Edit mode, the current parameter value will be saved automatically.

- Press the Back button (↩) to return to the previous screen or menu.

## 5.12 Diagnosing the Water Heater

You can diagnose each system component (fan, heating element, and valves) of the water heater.

- Press and hold the Menu button (M) and the Back button (↩) simultaneously for more than 5 seconds, and then select **Test Mode**.

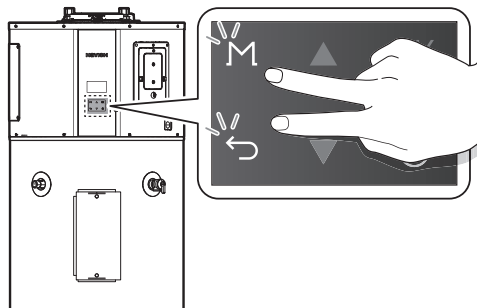

### Service / Installer

- Installer Menu
- Test Mode

- Press the Up (▲) or Down button (▼) to scroll through the items. Press the OK button (OK) to verify the proper operation for the system component.

Item	Description
1. Evaporate Fan	This procedure slowly increases the RPM of the evaporate fan motor from 0 to 900 (maximum) and then decreases it to 0. The current fan RPM value will be displayed on the front panel.
2. EEV	This procedure turns the valve to a fully closed position and then to a full open position. "Sound Check" will be displayed on the front panel during the test.

Item	Description
3. Leak Detection System	<p>This procedure turns the valve to a fully open position (0%) and then to a full close position (100%).</p> <ul style="list-style-type: none"> <li>• Check the feedback during the procedure.</li> <li>• When the procedure is complete, the valve returns to its latest status.</li> </ul>
4. Heating Element	<ul style="list-style-type: none"> <li>• Select between UHE (Upper Heating Element) or LHE (Lower Heating Element) to diagnose.</li> <li>• This procedure turns the heating element on and off for 5 seconds each, repeating the cycle three times in a row.</li> <li>• Current power status and the usage rate of the heating element will be displayed on the front panel.</li> </ul>
5. Recirc Pump Kit	<p>Press the Up (▲) or Down button (▼) to turn the recirculation pump on or off. If the recirculation pump on the water heater does not operate for 5 minutes, the test will end. Even if the pump is forced to run by selecting ON, if no flow is detected for more than 30 seconds, the pump will be deenergized to prevent damage.</p>

3. Press the Back button (←) to return to the previous screen or menu.

## 5.13 Setting the Display Options

You can configure display options, such as display unit, time, and error alarm, on the front panel.

1. Press and hold the Menu button (M) for more than 5 seconds and then select **6. Configuration**.

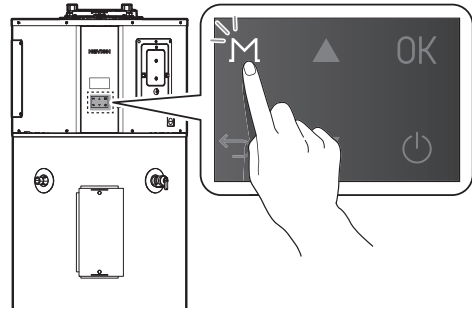

### Main Menu

- 3. System Information
- 4. Error History
- 5. EMS Data
- 6. Configuration**

2. Press the Up (▲) or Down button (▼) to scroll through the items. Press the OK button (OK) to set its configuration.

Item	Description
1. Display Units Setting	<p>Set the display units.</p> <ol style="list-style-type: none"> <li>1. °F, GPM, Feet</li> <li>2. °C, L/M, Meter</li> </ol> <ul style="list-style-type: none"> <li>• Default: °F, GPM, Feet</li> </ul>
2. Time Setting	<p>Set the time format.</p> <ul style="list-style-type: none"> <li>• Display: YYYY.MM.DD/HH:MM:SS</li> </ul>
3. Error Alarm	<p>Set the error alarm mode.</p> <ul style="list-style-type: none"> <li>• Setting range: On, Off</li> <li>• Default: Off</li> </ul>
4. Backlight Time Setting	<p>Set the backlight time.</p> <ul style="list-style-type: none"> <li>• Setting range: 0–60 min</li> <li>• Default: 1 min</li> </ul>

Item	Description
5. Sound Setting	Set the beep sound. <ul style="list-style-type: none"> <li>Setting range: On, Off</li> <li>Default: On</li> </ul>

- Press the Back button (↩) to return to the previous screen or menu.

## 5.14 Initializing All Parameter Settings (Factory Reset)

You can initialize all parameter settings and data of the water heater system to factory default.

- Press and hold the Menu button (M) and the Back button (↩) simultaneously for more than 5 seconds, and then select **Factory Reset**.

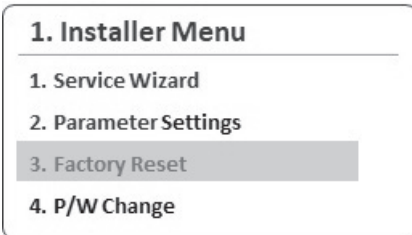
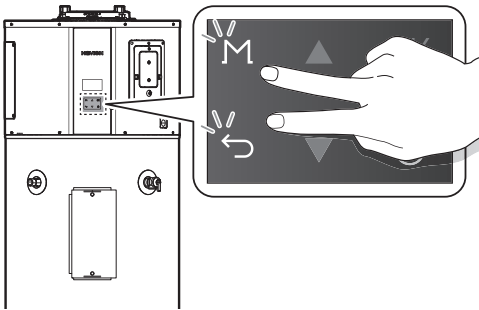

- Press the Up (▲) or Down button (▼) to select **Yes** and then press the OK button (OK) to initialize all parameter settings (panel and main controller) to the factory default. The factory reset process status will be displayed on the front panel. After the factory reset, the Start Wizard will run.

**Note** If you select **No** or press the Back button (↩), it will return to the previous screen or menu.

## 5.15 Connecting the NaviLink App with the Water Heater

By using the water heater's Wi-Fi communication to connect the NaviLink app with the water heater, you can monitor temperature settings and EMS data, turn the water heater on or off, schedule settings, and set the water temperature through the app. Follow the procedure below to connect the app and water heater.

- Search for "NaviLink" in the App Store (iOS) or Google Play Store (Android) and download the app to your smartphone. After installation is complete, launch the NaviLink app.



[Google Play Store]



[Apple App Store]

- Press and hold the Menu button (M) for more than 5 seconds, and then select **Setting**.

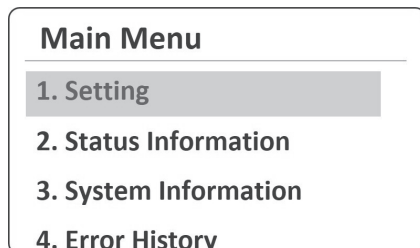
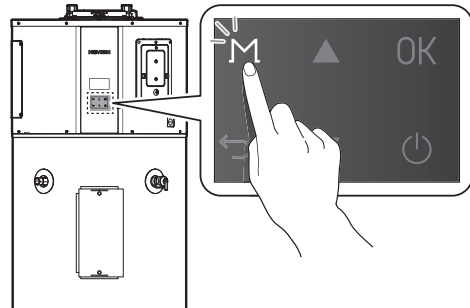

- From the Setting Menu, select **Communication** and set the Wi-Fi communication to On to enable it.

- Press and hold the Power button (⏻) to turn off the water heater.
- When the water heater is turned off, press and hold the Menu button (M) and the OK button (OK) simultaneously for 3 seconds. The water heater will be in Wi-Fi Connection mode.

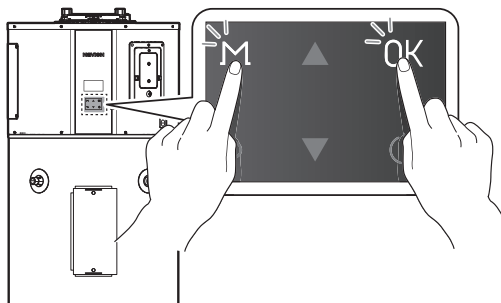

- When the guidance screen appears, press the OK button (OK).

Install the NaviLink app  
on your phone to setup WIFI.

The Wi-Fi connection ready mode screen will be displayed.

**READY**  
**HPWH xxxx**

- While the water heater is in Wi-Fi Connection mode, register the product (water heater) via the NaviLink app. If registration is successful, "WIFI CONN-SUCCESS" will be displayed on the front panel, and the water heater will complete Wi-Fi Connection mode and turn off automatically.

**Note** To exit Wi-Fi Connection mode and turn off the water heater, press and hold the Back button (↶).

## 5.16 Water Heater Protection Features

### 5.16.1 Heat Pump Operation Prevention

The heat pump will only operate when the ambient temperature around the product is between 41°F (5°C) and 113°F (45°C), and the water temperature inside the tank is between 50°F (10°C) and 149°F (65°C). Outside of these temperature ranges, the heat pump does not operate, and the front panel displays "Operation Prevention in Progress."

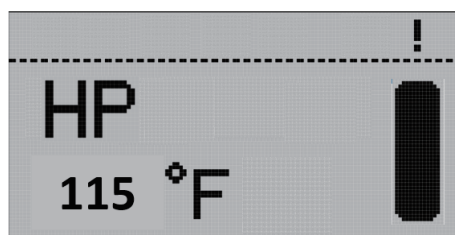

### 5.16.2 Freeze Protection

This protection feature prevents the freezing of water inside the tank. When the water temperature inside the tank falls below the set threshold (default: 43°F (6°C)), the electric heater is activated to raise the water temperature inside the tank. Once the water temperature inside the tank rises to a certain level, this operation stops. While the freeze protection feature is active, the front panel displays "Freeze Protection in Progress."

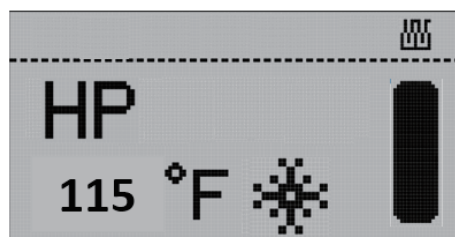

### 5.16.3 Anti-Seize

The electronic expansion valve (EEV) will operate for a set period at regular intervals to prevent seizing.

### 5.16.4 Alternating from Heat Pump to Electric Operation

If there is a problem with the heat source used in the selected operating mode and that heat source cannot be operated, tank heating will continue with the remaining alternative heat source that is confirmed to be in normal condition until the problematic heat source returns to normal.

- If the heat pump cannot operate, the electric heater will be used to heat the tank.
- If the electric heater cannot operate, the heat pump will be used to heat the tank.
- If the upper electric heater cannot operate, the lower electric heater will be used to heat the tank.

## 5.17 Component Test Features

These tests can be performed using the front panel to check each device's normal operation and identify any faults.

### 5.17.1 Evaporator Fan Test

This test will run and then stop the evaporator fan for 20 seconds. During operation, the current RPM value of the evaporator fan is displayed on the front panel.

### 5.17.2 Electronic Expansion Valve (EEV) Test

This test allows you to check the status by controlling the electronic expansion valve (EEV) between the minimum and maximum range. During the test, "SOUND CHECK" is displayed on the front panel. The water heater then adjusts the valve to the minimum range and waits 2 seconds, adjusts to the maximum range and waits 2 seconds, and then finally returns to the state before the test starts.

### 5.17.3 Navien Leak Detection System - Shut-Off Valve Test

This test performs Full Open and Full Close operations with the shut-off valve. Upon completion, the front panel will indicate the valve's operational status.

### 5.17.4 Heating Element Test

This test selects either the upper or lower heating element for testing. When the test starts, the ON/OFF cycle repeats three times, and the ON/OFF status and current power consumption are displayed on the front panel.

### 5.17.5 Recirculation Pump Test

This test turns the Recirculation Pump Kit on and off. The control status and recirculation flow rate are displayed on the front panel.

## 5.18 Additional Features

### 5.18.1 Hot Water Charge Display

This feature calculates the thermal energy (energy storage) status inside the tank based on the current water temperature and displays it on the front panel.

### 5.18.2 Anti-Legionella - Default: Disable

#### CAUTION

A mixing valve must be installed to prevent the risk of burns from high-temperature water when the anti-legionella feature is activated.

When the anti-legionella function is enabled, the water temperature in the tank will be heated to 140°F (60°C) at a set interval (default: 7 days, adjustable from 1 to 30 days) to prevent Legionella bacteria.

### 5.18.3 Demand Response (CTA 2045-B) - Default: Disable

#### **NOTICE**

In demand response applications, a thermostatic mixing valve certified to ASSE 1017 is required to be installed on the hot water outlet pipe. Refer to the installation instructions provided by the valve manufacturer.

If the CTA-2045 Module (or EcoPort Module) is connected to the product and the DR (Demand Response) function is enabled in the front panel settings menu, power usage control will be performed according to DR commands sent by the Electric Utility. Various commands, such as Shed or Load Up, can be received. Upon receiving a command from the Grid, normal operation will immediately stop, and the corresponding action will be performed. While performing actions in response to a DR command, the front panel will display the DR label. If necessary, you can disable the DR function to operate in normal mode, which will remain in effect for up to 72 hours (3 days).

### 5.18.4 Weekly Schedule - Default: Disable

When the weekly schedule feature is enabled, the tank's thermal storage operation is performed according to the schedule type and settings.

The schedule time, operating mode, and tank temperature settings can be configured. While operating using the schedule settings, if you change any settings (such as operating mode or tank temperature), the product will immediately operate according to the new settings. When the next scheduled operation time is reached, it will continue operating according to the previously reserved settings.

## 6. Maintaining the Water Heater

**Note** If you need assistance with component replacement, contact a licensed professional or Navien Technical Support at 1-800-519-8794.

To operate the water heater safely, perform proper routine maintenance. Follow the instructions in this chapter to ensure optimal performance, prevent potential issues, and extend the lifespan of the unit.

- At least once a year, open the T&P valve handle on the side of the water heater and release 1–2 gallons of water.
- Clean the air filter on top of the water heater at least once a year or whenever the air filter cleaning alarm is displayed on the front panel.
- The internal condensate system requires no maintenance unless a fault code or overflow condition occurs. (For more information, refer to “6.3 Inspecting the Condensate Drain” on page 65.)

### **⚠ WARNING**

- Follow the service and maintenance procedures given throughout this manual and in component literature shipped with the water heater.
- Failure to perform the service and maintenance could result in damage to the water heater or system.
- Failure to follow the directions in this manual and component literature could result in severe personal injury, death, or substantial property damage.
- The water heater must be inspected annually, preferably at the start of the heating season, by a qualified service technician. In addition, the maintenance and care of the water heater must be performed to assure maximum water heater efficiency and reliability. Failure to service and maintain the water heater and system could result in equipment failure.
- **Electrical shock hazard** – Turn off power to the water heater before any service operation on the water heater except as noted otherwise in this instruction manual. Failure to turn off electrical power could result in electrical shock, causing severe personal injury or death.
- After each act of maintenance or servicing, proper operation of the water heater must be verified by a qualified service technician.

### 6.1 Maintaining the T&P Relief Valve

#### **⚠ WARNING**

The water heater must be equipped with a T&P valve. Operating the water heater without the T&P valve may lead to the risk of explosion.

- When discharging water, ensure no one is nearby, as the temperature is extremely high.
- Do not block the T&P valve discharge outlet.

At least once a year, open the T&P valve's handle on the side of the water heater to drain 1–2 gallons of water, preventing the valve from sticking.

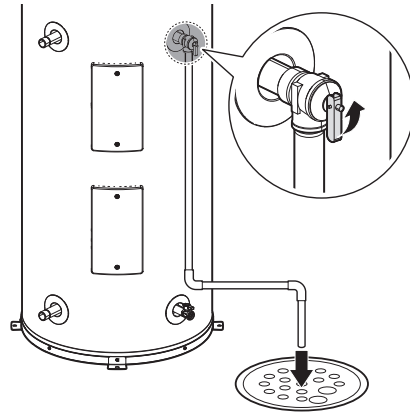

#### **Note**

- If no water is drained when the T&P valve's handle is opened, turn off the water heater and contact a licensed professional or Navien Technical Support at 1-800-519-8794.
- If there is a leak from the T&P valve, follow these guidelines:
  - Install a PRV (Pressure Reducing Valve) on the cold water inlet side. (Recommended pressure: 50–60 psi)
  - Install an expansion tank with the appropriate pressure.
  - Adjust the temperature setting as needed.



## **⚠ WARNING**

The water heater must be equipped with a T&P valve. Operating the water heater without the T&P valve may lead to the risk of explosion.

- When discharging water, ensure no one is nearby, as the temperature is extremely high.
- Do not block the T&P valve discharge outlet.

## 6.2 Cleaning the Air Filter

When an air filter alarm notification appears on the front panel, clean or replace (if required) the air filter on the intake air duct at the top of the water heater.

**Note** Although the filter is not clogged, clean the air filter at least once a year to help improve the water heater's efficiency.

1. Ensure the electrical power to the water heater is turned off.
2. Hold the air filter by its handle, then lift it up and pull it out from the intake air duct at the top of the water heater.

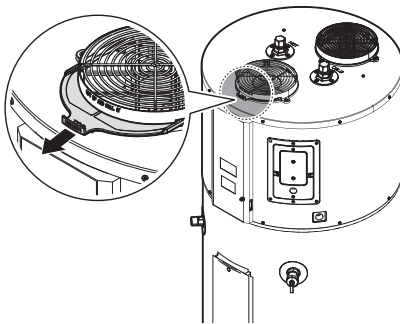

3. Remove dust or debris from the filter using water or a vacuum cleaner.

**Note** If you use water to clean the filter, make sure to dry it completely or wipe it down with a cloth.

4. Push the air filter all the way in to fully insert it into the intake air duct.

## 6.3 Inspecting the Condensate Drain

The internal condensate system requires no maintenance unless a fault code or overflow condition occurs.

- When such conditions occur, check whether the condensate drain pan or hose is clogged due to sediment or algae buildup.
- Compressor operation will automatically stop when condensate leakage or overflow is detected to protect the product and user safety.
- In case the condensate drain line is clogged, follow the instruction below to clean the line. Recommended cleaning tools include a cleaning brush, wet/dry vacuum cleaner, bleach, and other appropriate household items.

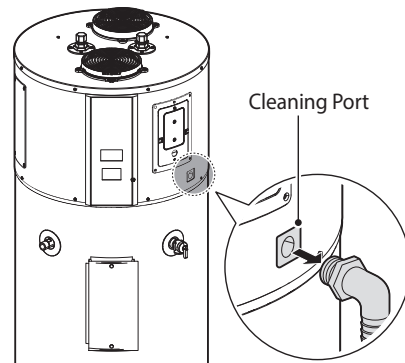

1. Ensure the electrical power to the water heater is turned off.
2. Remove the condensate drain and open the cleaning port.
3. Remove internal debris using a brush or pipe cleaner from the cleaning port.
4. Use a vacuum cleaner or bleach (if necessary) to remove remaining debris and foreign substances.
5. Restore the cleaning port and supply power to the water heater.

## 6.4 Draining and Flushing the Water Heater

At least once a year, drain and flush the water heater to remove mineral deposits and reduce unpleasant odors in the water.

1. Ensure the electrical power to the water heater is turned off.
2. Open all faucets and connect a hose to the drain valve.
3. Close the cold water supply valve and open the drain valve (Opening the T&P valve will speed up the draining process.).
4. Once draining is complete, close the drain valve and reopen the cold water supply valve.
5. Keep the faucets open while the storage tank fills with water.
6. When the storage tank is full, close the faucets and supply power to the water heater to turn it on.

### **WARNING**

- Ensure the power to the water heater is turned off before performing this procedure.
- After completing draining and flushing, make sure the storage tank is fully filled with water before supplying power to the water heater to turn on the water heater.

## 6.5 Maintenance for Extended Periods of Inactivity

If the water heater will be unused for an extended period, follow the instructions below.

- Disconnect the power supply to the water heater.
- Use the Vacation mode to save energy. To set the Vacation mode, refer to “5.5 Setting Operation Schedules and Configuring Communication Settings” on page 47.
- Be sure to drain the pipes to prevent the risk of freezing due to outdoor temperatures.

### **CAUTION**

Before turning the water heater back on after it has been unused for an extended period, make sure the storage tank is full of water. If the water heater is turned on without enough water in the tank, it may overheat, causing damage to the heating element. This may lead to malfunction, increased energy consumption, or even a complete failure of the system. Ensuring the tank is full of water helps prevent these risks and ensures safe operation.

## 6.6 Replacing the Heating Element

### **CAUTION**

The heating element is connected to high-voltage electricity, so always ensure the power is turned off before performing any work. Ensure the storage tank is full of water before turning on the water heater. After work is complete, close all covers to prevent electric shock and fire hazards.

When replacing the heating element, ensure that the power to the water heater is completely turned off.

1. Ensure the electrical power to the water heater is turned off.
2. Completely drain and flush the water heater. For more detailed instructions, refer to "6.4 Draining and Flushing the Water Heater" on page 66.
3. Remove the 2 screws from both the upper and lower heating element covers, then remove them from the water heater.

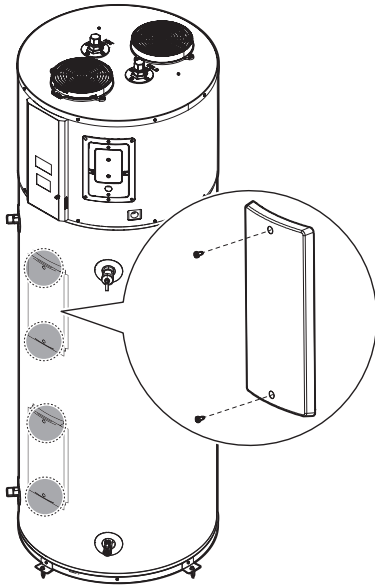

4. Remove the safety cover by pulling it forward.

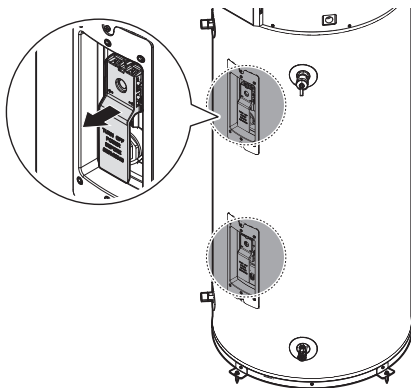

5. Remove the 2 screws on the heating element wires, then disconnect them from the heating element.

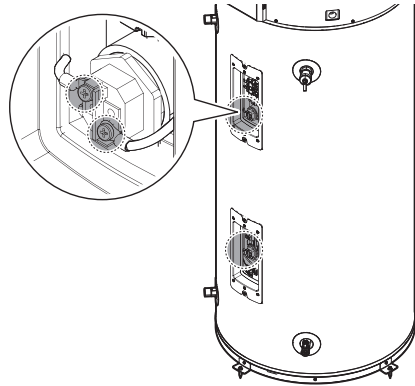

6. Use a socket wrench to turn the element counterclockwise, and remove it from the water heater.

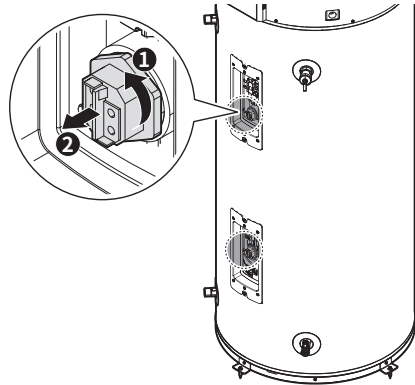

7. Replace with a new element, connect the 2 element wires to the element using 2 screws, then install both the safety cover and element cover on the water heater.
8. Supply water to the water heater and check for leaks on the element. If no leaks are detected, turn on the water heater and check if the water heater operates properly.

## 6.7 Replacing the Energy Cut Off (ECO) Switch

### **⚠ WARNING**

The energy cut off (ECO) switch is connected to high-voltage electricity, so always ensure the power is turned off before performing any work. After work is complete, close all covers to prevent electric shock and fire hazards.

When replacing the energy cut off (ECO) switch, ensure that the power to the water heater is completely turned off.

1. Ensure the electrical power to the water heater is turned off.
2. Remove the 2 screws from both the upper and lower heating element covers, then remove them from the water heater.

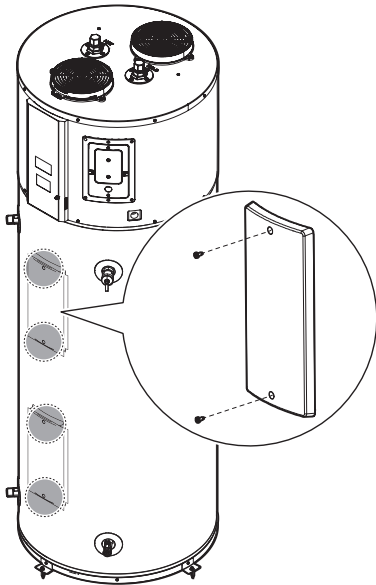

3. Remove the safety cover by pulling it forward.

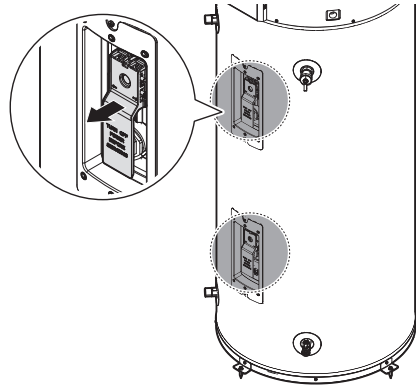

4. Remove the 4 screws on the ECO wires, 2 bolts on the ECO bracket from the water heater. Then, disconnect the wires from the ECO switch.

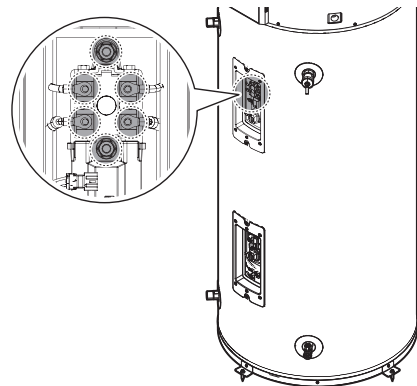

5. Separate the ECO switch from the ECO bracket to remove it.

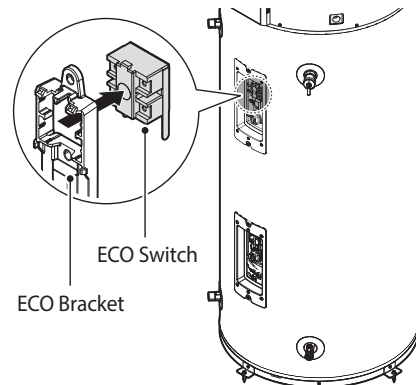

6. Replace with a new ECO switch, connect the 4 ECO wires to the ECO switch using 4 screws, then install both the safety cover and heating element cover on the water heater.
7. Turn on the water heater and check if the water heater operates properly.

## 6.8 Replacing the Battery on the Front Panel

### **CAUTION**

- Impacting the battery may cause an explosion.
- Do not attempt to recharge the battery.
- After replacing the battery, you may need to set the time on the front panel.

The water heater is shipped from the factory with a protective film on the battery. After completing the installation and before connecting the water heater to power, remove the battery protective film from the side of the front panel. It is recommended to replace the battery every five years.

## 6.9 Setting the DIP Switches

The water heater has 8 dip switches on the back of the front panel. Dip switches 3 and 4 can be used to set the capacity of the heat pump water heater. The capacity setting is set at the factory and cannot be changed except when the front panel is replaced.

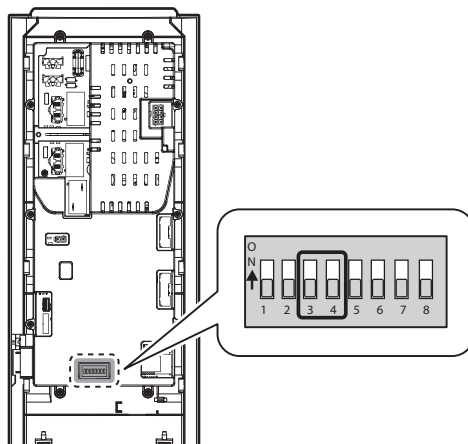

Capacity	DIP SW 3	DIP SW 4
50 Gallon	OFF	OFF
65 Gallon	ON	OFF
80 Gallon	OFF	ON
Setting Error	ON	ON

## 6.10 Installing Emergency Part Kit for Repairs

The emergency parts kit for repairs includes three types of O-rings and fuses. Use these components to replace damaged parts, if necessary.

### O-Ring Replacement Locations

If the O-rings on the upper, lower, or side pipes need replacement, use the corresponding O-rings provided in the Emergency Parts Kit.

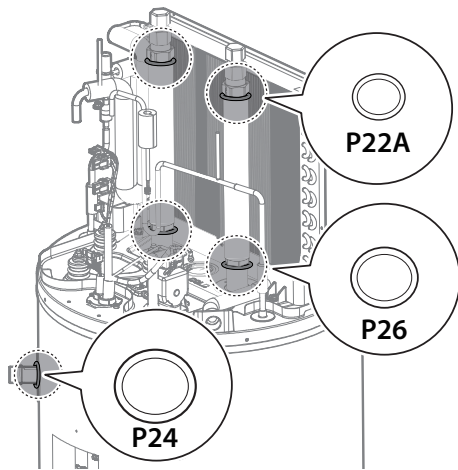

O-ring Type	Location
P22A	Top Pipe Upper
P26	Top Pipe Lower
P24	Side Pipes

### **⚠ WARNING**

Using a damaged O-ring or installing an O-ring improperly may cause water leaks, which could result in severe personal injury or property damage.

### Fuse Replacement Location

If the fuse located on the back of the front panel is blown, replace it with the fuse provided in the Emergency Parts Kit.

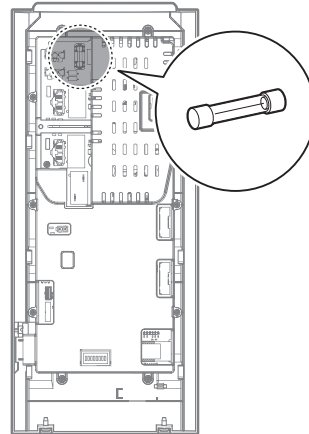

## 7. Troubleshooting

### 7.1 Solving Basic Problems

If you experience a problem with the water heater, refer to the following chart for possible remedies. Error codes that appear on the front panel display are explained in the following section.

For minor problems, resetting the water heater may resolve the issue. To reset the water heater, press the Back button (↶) on the front panel.

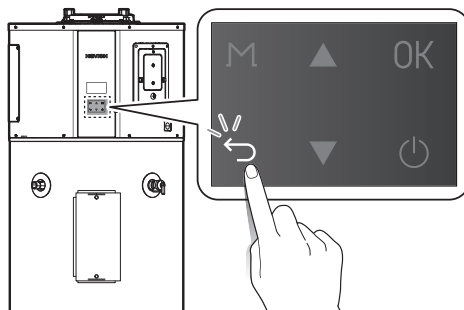

#### **⚠ WARNING**

- If resetting the water heater and attempting the remedies suggested below do not resolve the problem, contact an authorized technician, a licensed professional, or Technical Support at 1-800-519-8794 for service instructions.
- Do NOT attempt to service or repair the water heater yourself.

Problem	Possible Causes	What to Do
Rumbling noise	Water conditions in your home caused a buildup of scale or mineral deposits in the water heater.	Allow a few quarts of water to run from the drain valve to remove sediment settings.
Relief valve producing popping noise or draining	Pressure build up caused by thermal expansion in a closed system	This is an unacceptable condition and must be corrected. Contact a licensed professional or Navien Technical Support at 1-800-519-8794 for assistance.
Not enough or no hot water	Water usage may have exceeded the capacity of the water heater.	Wait for the water heater to recover after an abnormal demand.
	A fuse is blown or a circuit breaker tripped.	Replace fuse or reset circuit breaker.
	Electric supply may be turned off.	Confirm that electric supply to the water heater is properly connected. For more detailed instructions, refer to "3.6 Connecting the Power Supply" on page 28.
	The thermostat may be set too low.	Check the water heater's temperature setting. Refer to "5.3 Selecting the Operation Mode & Adjusting Water Temperature" on page 45.

Problem	Possible Causes	What to Do
Not enough or no hot water	Leaking or open hot water faucets	Make sure all faucets are closed and check for plumbing leak.
	Electric service to your home may be interrupted	Contact the local electric utility.
	Improper wiring or sensor failure	Confirm that power supply wires are properly connected. For more detailed instructions, refer to "3.6.1 Connecting the Power Supply Wires" on page 29.
	Manual reset limit(ECO)	Check the temperature regulation of the water heater. For more information, refer to "Important Safety Information" on page 5 for more information.
	The water heater may be in Vacation Mode.	To disable Vacation Mode, refer to "5.5 Setting Operation Schedules and Configuring Communication Settings" on page 47.
	Cold water inlet temperature may be colder during the winter months	This is normal. The colder inlet water takes longer to heat.
	Not enough air exchange for Efficient Heat Pump Operation	If the air temperature drops more than 15°F (8°C) during Heat Pump Operation, more air circulation around heater is required.
Delayed hot water at fixture with recirculation mode ON	<ol style="list-style-type: none"> <li>1. Recirculation pump OFF temperature set too low</li> <li>2. Insufficient recirculation pump operation time</li> <li>3. No water flowing in the recirculation piping</li> </ol>	<ol style="list-style-type: none"> <li>1. On page 54, adjust the recirculation Off Diff. Temp setting or increase tank set temperature.</li> <li>2. On page 54, adjust the Recirculation Interval Time setting to extend pump operation time.</li> <li>3. Use Recirculation Pump Test to check flow rate and verify whether water is circulating. If not, inspect for issues such as clogged pump, strainer blockage, or trapped air in piping.</li> </ol>
Water is too hot	The thermostat is set too high	Check the water heater's temperature setting. Refer to "5.3 Selecting the Operation Mode & Adjusting Water Temperature" on page 45.
	The Anti-Legionella function may be used.	This water heater is factory set to heat up to 120°F (49°C) once a week to prevent Legionella bacteria. Disable this function or adjust the heating frequency in the settings. To disable the function, refer to "Setting the Protection Function" on page 57.
Water odor	Harmless bacteria present in tap water	A higher tank temperature setting of 140°F (60°C) kills the bacteria that cause 'smelly water' and can help reduce the levels of bacteria that cause waterborne diseases. A properly adjusted thermostatic mixing valve should be installed at each point of use.
Low water pressure	Partially closed supply valve	Open the water heater's supply valve fully.



## 7.2 Understanding Error Codes

When an error code appears on the front panel, refer to the following table for a definition and possible remedy for the situation.

**Note** If any of these remedies do not resolve the problem, contact Technical Support at 1-800-519-8794.

Error Code	Sub Code	Reason	Self-diagnostic/Action
E096	00	Abnormal upper electric heater operation	1. Check the resistance of the heating element. 2. Check the wiring of the heating element. 3. Replace the control board. 4. Replace the heating element. 5. Replace the relay. 6. Contact technical support at 1-800-519-8794.
E097	00	Abnormal lower electric heater operation	
E326	00	Dry fire	Refill water until all air is expelled from the outlet and water flows.
E407	01	Abnormal hot water-temp sensor operation for lower limit	1. Check and reconnect the wiring. 2. Contact technical support at 1-800-519-8794.
	02	Abnormal hot water-temp sensor operation for upper limit	
E445	01	Abnormal mixing valve open	1. Replace the mixing valve. 2. Contact technical support at 1-800-519-8794.
	02	Abnormal mixing valve close	
E480	01	Abnormal tank upper temperature sensor operation for lower limit	1. Check and reconnect the wiring. 2. Check for disconnection in Service Mode. 3. If there is no wiring issue, replace the temperature sensor.
	02	Abnormal tank upper temperature sensor operation for upper limit	
E481	01	Abnormal tank lower temperature sensor operation for lower limit	<ul style="list-style-type: none"> <li>If the tank temperature sensor is faulty, operate in a reduced capacity using the opposite heating element.</li> </ul>
	02	Abnormal tank lower temperature sensor operation for upper limit	
E515	25	Upper electric heater relay fault	1. Check and reconnect the wiring. 2. Replace the relay.
	26	Lower electric heater relay fault	
	27	Compressor relay fault	
E517	00	Abnormal DIP switch settings	Check and reset the DIP switch configuration.
E593	00	Abnormal panel key	Contact technical support at 1-800-519-8794.
E594	00	Abnormal EEPROM operation	
E595	00	Abnormal power meter	1. Check and reconnect the wiring. 2. Replace the power meter.

Error Code	Sub Code	Reason	Self-diagnostic/Action
E596	00	Abnormal Wi-Fi connection	Contact technical support at 1-800-519-8794.
E598	00	Abnormal RTC (Real-Time Clock)	
	04	Abnormal ADC reference voltage	
E615	27	Abnormal ECO feedback	1. Check the heating element. 2. Check the thermistor. 3. Replace the control board.
	28	Abnormal compressor feedback	1. Check and reconnect the wiring. 2. Contact technical support at 1-800-519-8794.
	29	Abnormal upper heating element feedback	1. Check and reconnect the wiring. 2. Replace the heating element.
	30	Abnormal lower heating element feedback	
E743	01	Abnormal recirculation pump return water sensor for lower limit	1. Replace the recirculation pump kit. 2. Contact technical support at 1-800-519-8794
	02	Abnormal recirculation pump return water sensor for upper limit	
E766	00	Abnormal recirculation pump kit communication	Check and reconnect the wiring.
E781	00	Abnormal CTA-2045 communication	1. Check and reconnect the wiring. 2. Replace the module.
E798	00	Abnormal shut-off valve	1. Check and reconnect the wiring. 2. Contact technical support at 1-800-519-8794.
E799	00	Water leak detected	1. Check for piping leaks. 2. If there is a tank leak, replace the entire tank assembly.
E901	00	Abnormal ECO operation	1. Check the heating element. 2. Check the thermistor. 3. Replace the control board.
E907	00	Abnormal compressor power line connection	Check and reconnect the wiring of the compressor.
E908	00	Abnormal compressor operation	1. Check and reconnect the wiring. 2. Contact technical support at 1-800-519-8794.
E909	01	Abnormal evaporator fan operation	
E910	01	Abnormal compressor's discharge temperature sensor operation for lower limit	
	02	Abnormal compressor's discharge temperature sensor operation for upper limit	
E911	00	Abnormally high compressor's discharge temperature	Contact technical support at 1-800-519-8794.

Error Code	Sub Code	Reason	Self-diagnostic/Action
E912	01	Abnormal compressor's suction temperature sensor operation for lower limit	1. Check and reconnect the wiring. 2. Contact technical support at 1-800-519-8794.
	02	Abnormal compressor's suction temperature sensor operation for upper limit	
E913	00	Abnormally low compressor's suction temperature	Contact technical support at 1-800-519-8794.
E914	01	Abnormal evaporator temperature sensor operation for lower limit	1. Check and reconnect the wiring. 2. Contact technical support at 1-800-519-8794.
	02	Abnormal evaporator temperature sensor operation for upper limit	
E915	00	Abnormal difference of (compressor's discharge temperature) - (compressor's suction temperature)	Contact technical support at 1-800-519-8794.
E916	00	Abnormal evaporator temperature	Contact technical support at 1-800-519-8794.
E920	01	Abnormal ambient air temperature sensor operation for lower limit	1. Check and reconnect the wiring. 2. Contact technical support at 1-800-519-8794.
	02	Abnormal ambient air temperature sensor operation for upper limit	
E940	00	Refrigerant line blockage	1. Check the electronic expansion valve (EEV) operation status for seizing. 2. Contact technical support at 1-800-519-8794.
E990	00	Condensate overflow detected	Condensate leakage/overflow detected - Compressor operation has automatically stopped. Check for and remove any foreign objects from the condensate tubing before restarting.

# 8. Appendixes

## 8.1 Wiring Diagram

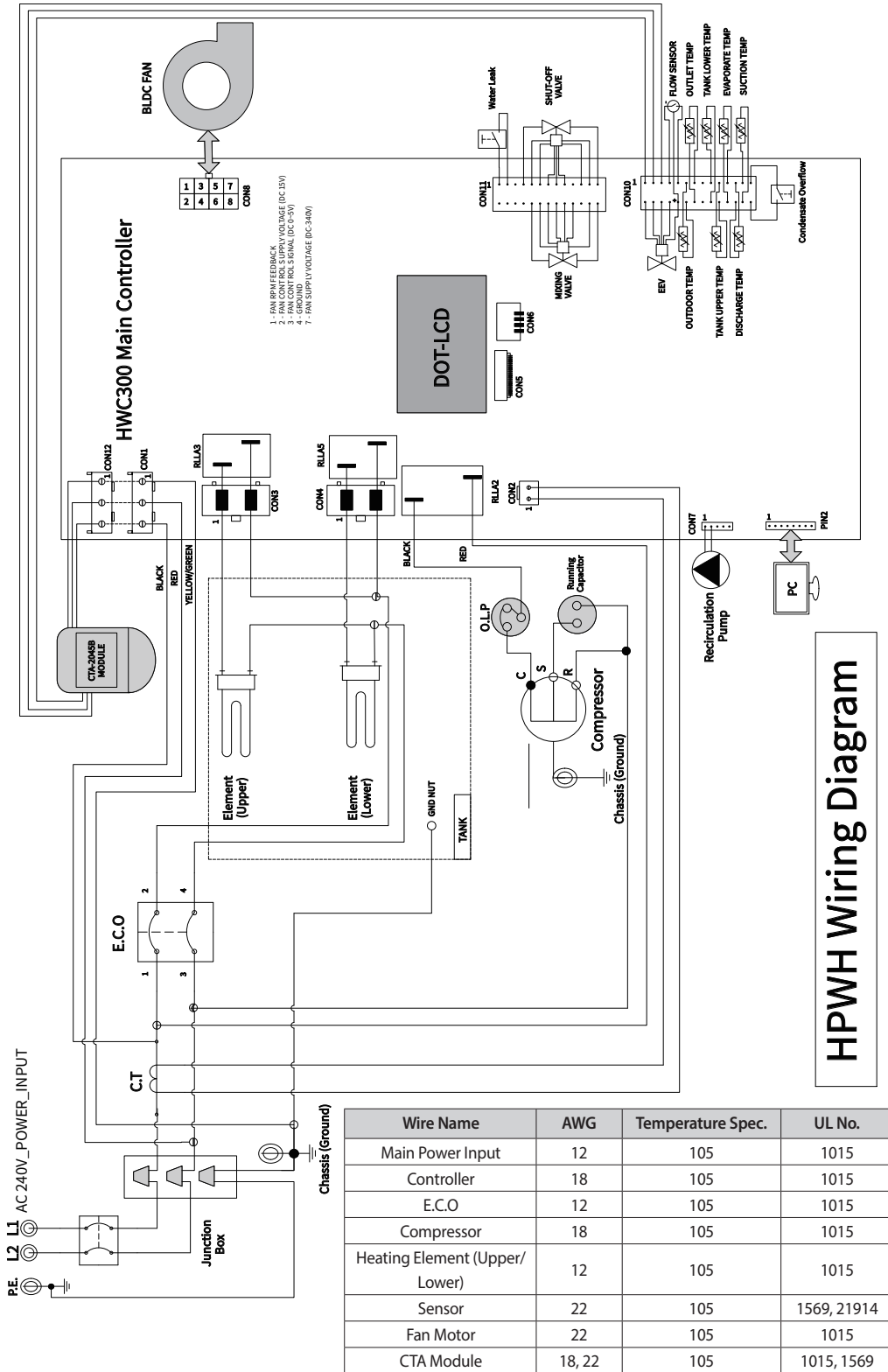

## 8.2 Component Assembly Diagrams and Parts Lists

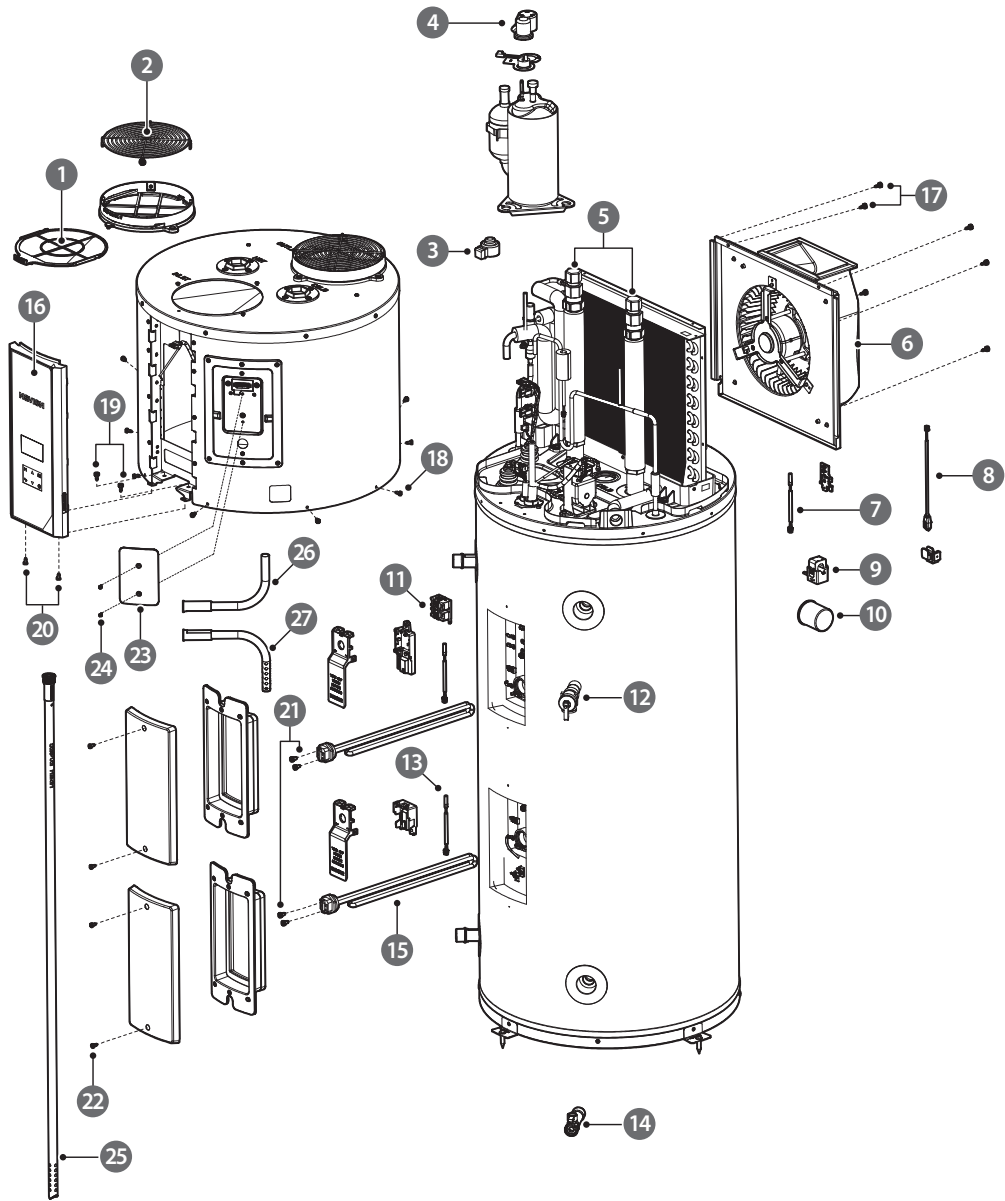

#	Part Name	Service Code	Remark
1	Intake Filter	20068915*	
2	Intake Filter Grille	20072241*	
3	Electronic Expansion Valve (EEV) Coil	30036215*	
4	Overload Protector	30036800*	
5	Upper Inlet & Outlet Pipe	30036106*	
6	Fan Assembly	30035398*	
7	Outside Air Temp sensor	30038926*	
8	Water Leak Detection Sensor	30031685*	
9	CT Sensor	20071987*	
10	Capacitor	20071120*	
11	Energy Cut Off (ECO) Switch	30035521*	
12	Temperature and Pressure (T&P) Relief Valve (150 psi)	30036068*	
13	Heating Element Temperature Sensor	30038926*	
14	Drain Valve	30036062*	
15	Heating Element	30036069*	
16	Control Assembly	30036288*	
17	Fan Assembly Fixing Screw	20072676*	
18	Top Kit Fixing Screw (Side)	20072409*	
19	Top Kit Fixing Screw (Bottom)	20072676*	
20	Main Controller Screw	20072408*	
21	Heating Element Wire Screw	20077432*	
22	Heating Element Case Fixing Screw	20072407*	
23	CTA-2045 Cover	-	Not supplied
24	CTA-2045 Cover Screw	-	Not supplied
25	Upper Inlet Tube (Dip Tube)	-	Not supplied
26	Optional Side Outlet Tube	-	Not supplied
27	Optional Side Inlet Tube	-	Not supplied

# LIMITED WARRANTY NAVIEN, INC.

This Limited Warranty is provided by Navien, Inc. ("Navien") to cover only labor, parts and the tank for the Navien NWP500 Heat Pump Water Heater ("Product") as originally installed by a properly licensed plumber or contractor and operated in strict compliance with the Installation & User's Information Manuals procedures and subject to the terms within this Warranty document. Improper installation or use will void this Warranty.

## How Long is the Coverage?

The warranty periods begin from the date of original installation ("Commencement Date"), and proof of such date must be provided to Navien. When the Product is installed in new construction, the Commencement Date shall be the date that the end-user takes title to the property. If proof of the installation date is unavailable, then the original installation date shall be deemed to be six months after the unit's manufacture date.

This Warranty runs from the Commencement Date and extends to the original purchaser and subsequent owners ("Purchaser"), but only while the Product remains at the site of the original installation. This Warranty includes a limited warranty as set forth herein.

## What is covered?

Subject to the terms and conditions set forth in this limited warranty, Navien will repair or furnish replacement parts, at no charge, for installation by a qualified service provider, if the part fails due to a manufacturing defect under normal use and maintenance. This limited warranty for the Applicable Warranty Periods specified herein ("Warranty") covers defects in materials or workmanship when the Product is installed by a properly licensed plumber or contractor and operated in strict compliance with the Installation & User's Information Manuals procedures, subject to the terms within this Warranty document. Navien will pay reasonable labor charges for the repair subject to Navien's prior written approval and in accordance with Navien's schedule of approved labor allowances for a period of one (1) Year from the Commencement Date. All repair parts must be genuine Navien parts unless otherwise authorized by Navien. All repairs and replacements must be performed by an individual or servicing company that is qualified to do the type of repair. During the applicable warranty period, replacement of the Product or part requires Navien's direct prior written approval, and no third party is authorized to provide such approval on behalf of Navien. The replacement part or Product will be warranted only for the unexpired portion of the applicable warranty period for the original part or Product.

## Applicable Warranty Periods

NWP500 Series – Coverage Table for Labor, Parts, and Tank Only		
	Residential*	Commercial
Labor	1 Year	No coverage for Commercial Use
Parts	10 Years	
Tank	10 Years	

\*Residential use means a Single-Family Residence

## Eligibility Requirements

To be covered under this limited warranty, the Product or Parts must meet the following requirements: (i) The Product must be in the same location where it was originally installed; (ii) The Product must be properly installed, operated, and maintained by a licensed HVAC service provider in accordance with the specifications or installation, operation, and maintenance instructions provided by Navien, and you must upon request, present written maintenance records, (iii) The Product or Parts replaced under this limited warranty must be given to the servicing provider for return to Navien; and (iv) All claims under this limited warranty must be filed within 30 days of the failure date.

## How do I get service?

You must contact the original installer of your Product who must then contact Navien to report the issue. If you cannot find or do not wish to use the original installer, you may choose any service provider who is qualified to complete the necessary repair. Your service provider must contact and obtain approval from Navien's Technical Support team at 800-519-8794 or an authorized Navien distributor prior to commencing any warranty service. The installer and/or service provider must comply with Navien's warranty service and return procedures as available on Navien's website.

## What is not covered?

This warranty does not cover issues that are cosmetic and have no effect on the functionality of the Product, or for reasons of noise, taste, odor, discolored and/or rusty water. This warranty does not cover damage to the surrounding property. A properly sized metal drain pan must be installed in an area where leakage from the tank or its connections would result in damage to the area adjacent to the water heater. This warranty does not apply to water heaters used to heat pools, whirlpools or hot tubs or used for space heating. This warranty gives you specific legal rights, and you may have other rights which vary under the laws of each state. If any provision of this warranty is prohibited or invalid under applicable state law, that provision shall be ineffective to the extent of the prohibition or invalidity without invalidating the remainder of the affected provision or the other provisions of this warranty.

Additional terms and conditions are continued on the reverse side.



Customer Name :	
Customer Address :	
Telephone :	Fax :
Email :	
Installer Name :	License No :
Installer Address :	
Place of Purchase :	
Model No :	
Serial No :	
Date of Purchase :	



**Navien, Inc.**  
 20 Goodyear, Irvine, CA 92618  
 Tel : 1-800-519-8794  
 Fax : 949-420-0430  
[www.navieninc.com](http://www.navieninc.com)

For instant warranty registration, please register your product online at [www.navieninc.com](http://www.navieninc.com)

Navien's Limited Warranty shall be void in the event of an occurrence of any of the following:

- Product purchased through the internet, other e-commerce channels, or any installer that obtained the Product from a supplier or distributor not authorized by Navien.
- Improper installation, failure to install in strict compliance with the Installation Manual procedures, installed by a non-licensed installer, and installation in violation of applicable rules, fire codes, plumbing codes, ordinances, regulations, good industry practices and proper safety practices.
- Failure to perform regular maintenance, misuse, operation at settings other than those recommended or specified, non-compliance with instructions or guidelines set forth in the User's Information Manual.
- Modification or alteration of the Product in any manner, including but not limited to, removal of any component or part, addition of any nonapproved components, relocating or moving the Product from its original installation site, or any accidental or intentional damage to the Product.
- Installation for non-recommended uses including Commercial use. Or installation outdoors.
- Any damage caused by local adverse conditions including but not limited to hard water deposits, lime or mineral build-up, operating in corrosive atmospheric elements; any operation of the water heater on desalinated (deionized) water.
- Any damage, malfunction or failure caused by abuse, negligence, alteration, accident, fire, flood, freezing, wind, lightning, power supply issues, electrical surges, acts of God, abnormal external temperature, and any other cause of damage not directly caused by a manufacturing defect.
- Installer's failure to fully comply with the Warranty Service and Return Policy procedures as available on Navien's website. Such policies include but are not limited to the Installer's failure to first contact Navien Tech Support while in front of the product for purposes of trouble shooting the identified problem or issue.
- Performance problems caused by improper sizing of the water heater, the venting connection, combustion air openings, electric service voltage, wiring, fusing or any other components, parts or specifications.
- Operating, using or storing the water heater in a corrosive or contaminated atmosphere or environment.
- Operating the water heater at water temperatures outside the factory calibrated temperature limits and/or exceeding the maximum setting of the high limit control.
- Operating the water heater when it is not supplied with potable water at all times, free of damaging water sediment or scale deposits.
- If a new temperature and pressure relief valve, certified by the Canadian Standards Association, is not properly installed and piped to the nearest drain.
- Any damage caused by attempts to repair tank leaks or parts
- Installation at any location outside the United States and Canada.
- Removal or alteration of the rating plate.
- Used at water pressures exceeding 80 psi static pressure.

- When water is not able to freely circulate at all times and with the tank; dry-firing.
- Installation anywhere other than its original installation location.
- Product is not sized in accordance with proper sizing techniques for residential water heaters.
- Product is not being used with a properly sized and installed thermal expansion tank.
- Product is not connected to the proper voltage or operated outside of the factory rated input.
- Any attempt to modify or alter the water heater's design in any way, including but not limited to, the attachment of non-company approved appliances or equipment, including any additional aftermarket equipment introduced into the sealed system.

## Warranty Limitations

EXCEPT AS EXPRESSLY PROVIDED HEREIN, THERE ARE NO OTHER WARRANTIES, EXPRESSED OR IMPLIED, INCLUDING, BUT NOT LIMITED TO WARRANTIES OR MERCHANTABILITY OR FITNESS FOR A PARTICULAR PURPOSE, WHICH EXTEND BEYOND THE DESCRIPTION OF THE WARRANTY HEREIN AND FURTHER NAVIEN SHALL NOT BE LIABLE FOR INDIRECT, INCIDENTAL, SPECIAL, CONSEQUENTIAL, PUNITIVE OR OTHER SIMILAR DAMAGES THAT MAY ARISE, INCLUDING LOST PROFITS, DAMAGE TO A PERSON OR PROPERTY, LOSS OF USE, INCONVENIENCE, OR LIABILITY ARISING FROM IMPROPER INSTALLATION, SERVICE OR USE OF THE PRODUCT. ANY IMPLIED WARRANTIES OF MERCHANTABILITY AND FITNESS ARISING UNDER STATE LAW ARE LIMITED IN DURATION TO THE PERIOD OF COVERAGE PROVIDED BY THIS WARRANTY, UNLESS THE PERIOD PROVIDED BY STATE LAW IS LESS.

No one is authorized to make any other warranties on behalf of Navien. Some states do not allow the exclusion or limitation of incidental or consequential damages, or how long an implied warranty lasts, so the above limitation may not apply to you. This Limited Warranty gives you specific legal rights and you may also have other rights which vary from state to state. If this Product is considered a consumer product, please be advised that some local laws do not allow exclusions or limitations on incidental or consequential damages, or limitations on how long a warranty lasts; or how long an implied warranty lasts, so that the above limitations may not apply to you. Refer to your local laws for your specific rights under this limited warranty. If you have any questions regarding this limited warranty, please contact your original installation dealer, or any participating dealer, should your original installation dealer no longer be available. No action arising out of any claimed breach of this limited warranty may be brought by the Purchaser (or any subsequent purchaser retaining the balance of a properly transferred limited warranty) more than one (1) year after the cause of action or claim has arisen.

Rev. April, 2025

**Retain this document for future reference.**





# *Memo*

---



# Installation Manual

## NWP500 Electric Heat Pump Water Heaters

### Getting Service

If your water heater requires service:

- All repairs require pre-authorization by Technical Support.
- Request for your installer or any licensed professional to contact Technical Support at 1-800-519-8794 Option 2 once at the installation site.
- A short list of independent service providers in your area can be found on the website: [www.navieninc.com/installers](http://www.navieninc.com/installers).
- Contact a licensed professional for the affected system (for example, a plumber or electrician).

When you contact Technical Support, please have the following information at hand:

- Model number
- Serial number
- Date purchased
- Installation location and type
- Error code, if any appears on the front panel display

Version: 1.0 (November, 2025)



Navien, Inc.  
800.519.8794 [www.navieninc.com](http://www.navieninc.com)  
20 Goodyear, Irvine, CA 92618